

### PAVING SCHEDULE

KEY	ITEM/DESCRIPTION	COLOR	DETAIL/SHEET	FINISH	SUPPLIER	COMMENTS
P-01	PORPHYRY GRECA DETAIL (AT CONCRETE ACCENT PLAZAS)	RED BLEND PORPHYRY	1 / LANDSCAPE SITE DETAILS SHEET 1	12" X 12" SQUARE, SQ. PATTERN	MILESTONE IMPORTS	SEE DETAIL & ENLARGEMENT PLANS. SEE PORPHYRY PAVING SPEC.
P-02	PORPHYRY PAVING (AT WALKWAY)	RED BLEND PORPHYRY	2 / LANDSCAPE SITE DETAILS SHEET 1	4" X 4" SQUARE PATTERN	MILESTONE IMPORTS	SEE DETAIL & ENLARGEMENT PLANS. SEE PORPHYRY PAVING SPEC.
P-01	CONCRETE ACCENT PLAZA FIELD (MID-BLOCK)	SCOFIELD "SOMBRERO BUFF"	1 / LANDSCAPE SITE DETAILS SHEET 1	TOPCAST, SEE SPECS. 12" GRID.	GCP (TOPCAST), DAVIS COLOR	SEE DECORATIVE CONCRETE FINISHES SPEC
P-02	CONCRETE GRECA DETAIL (WALKWAY)	SCOFIELD "SOMBRERO BUFF"	2 / LANDSCAPE SITE DETAILS SHEET 1	TOPCAST, SEE SPECS. 12" GRID.	GCP (TOPCAST), DAVIS COLOR	SEE DECORATIVE CONCRETE FINISHES SPEC
P-05	CONCRETE PAVING (SIDEWALK)	GREY, CoSA STANDARD	1 / LANDSCAPE SITE DETAILS SHEET 2	TOPCAST, SEE SPECS. 24" GRID	GCP (TOPCAST)	SEE DECORATIVE CONCRETE FINISHES SPEC
P-05 SIM	CONCRETE PAVING (ON-STREET PARKING)	GREY, CoSA STANDARD	SEE CIVIL DWGS FOR VEHICULAR PAVING	TOPCAST, SEE SPECS. 24" GRID	GCP (TOPCAST)	SEE DECORATIVE CONCRETE FINISHES SPEC
P-06	PORPHYRY PAVING (CROSSWALK)	RED BLEND PORPHYRY	2 / LANDSCAPE SITE DETAILS SHEET 2	4" X 4" CUBES, ARC FIELD+GRID BANDS	MILESTONE IMPORTS	SEE DETAIL & ENLARGEMENT PLANS. SEE PORPHYRY PAVING SPEC.
P-09	CRUSHED STONE MULCH	LIGHT TAN / BROWN	3 / LANDSCAPE SITE DETAILS SHEET 2	DECOMPOSED GRANITE	COLLIER MATERIALS	SEE CRUSHED STONE SPECS
	CONCRETE PAVING, CYCLE TRACK (SEE CIVIL DRAWINGS)	GREY, CoSA STANDARD	SEE CIVIL DRAWINGS	CoSA STANDARD		SEE CIVIL DRAWINGS

### AMENITIES SCHEDULE

KEY	ITEM/DESCRIPTION	COLOR	DETAIL/SHEET	FINISH	SUPPLIER	COMMENTS
A-01	CHAIR (BACKED AND BACKLESS)	THERMALLY MODIFIED ASH (DSTMA) SEAT	1 / LANDSCAPE SITE DETAILS SHEET 3	DSTMA WOOD SEAT, ALUMINUM	LANDSCAPE-FORMS	SEE SITE FURNISHING SPECS
A-02	BENCH (LIMESTONE BLOCK)	TEXAS LIMESTONE, CREAM COLOR	2 / LANDSCAPE SITE DETAILS SHEET 3	STONE FINISHES TOP: MACHINE SMOOTH/HONED FINISH ALL FACES: MACHINE SMOOTH/HONED FINISH BOTTOM EDGE: SAWN ALL OTHER EDGES: 3/4" CHAMFER		SEE STONE MASONRY SPECS
A-05	BOLLARD TYPE 1	"JAGUAR TOPAZ"	3 / LANDSCAPE SITE DETAILS SHEET 3	POWDER COAT	FAIR-WEATHER	SEE SITE FURNISHING SPECS
A-06	BOLLARD TYPE 2 (REMOVABLE)	"JAGUAR TOPAZ"	4 / LANDSCAPE SITE DETAILS SHEET 3	POWDER COAT	FAIR-WEATHER	SEE SITE FURNISHING SPECS
A-08	BIKE RACK	"SILVER TEXTURE"	5 / LANDSCAPE SITE DETAILS SHEET 3	POWDER COAT	FORMS + SURFACES	SEE SITE FURNISHING SPECS
A-09	TRASH & RECYCLING BIN	CITY STANDARD	6 / LANDSCAPE SITE DETAILS SHEET 3	POWDER COAT	VICTOR STANLEY SD-42	SEE SITE FURNISHING SPECS
A-09	VIA BUS SHELTER		1 / LANDSCAPE SITE DETAILS SHEET 4			VIA STANDARD SHELTER
A-09	PEDESTRIAN LIGHT (SEE ILLUMINATION PLAN)		SEE ELECTRICAL DRAWINGS			SEE ELECTRICAL DRAWINGS FOR PRODUCT INFORMATION.

### GENERAL NOTES:

- ALL WORK SHALL BE PERFORMED IN ACCORDANCE WITH DRAWINGS APPROVED BY THE CITY OF SAN ANTONIO.
- BASE INFORMATION PROVIDED BY CIVIL ENGINEER. REFER TO SURVEY, PLAT, ROADWAY AND UTILITY DRAWINGS, AND OTHER AVAILABLE DOCUMENTS FOR PROPERTY LIMITS, EXISTING CONDITIONS, PROPOSED UTILITIES AND HORIZONTAL AND VERTICAL CONTROL.
- THE LIMITS OF WORK OCCUR AT THE PROPERTY LINE OR AS SHOWN ON PLANS.
- VERIFY EXISTING SITE CONDITIONS INCLUDING, WALLS, VEGETATION FENCES, UTILITIES, PROPERTY LINES, LIMITS OF ROADWAYS, CURBS AND GUTTERS, AND OTHER OBSTRUCTIONS THAT MAY AFFECT THE PROGRESS OF WORK.
- LOCATE UTILITIES AND MAINTAIN THEIR LOCATION DURING ALL PHASES OF WORK. DO NOT DAMAGE UTILITY LINES/STRUCTURES. NOTIFY ENGINEER OF ANY DISCREPANCIES BEFORE STARTING ANY WORK. CONTRACTOR SHALL BE RESPONSIBLE FOR LOCATION AND PROTECTION OF UNDERGROUND UTILITIES OR STRUCTURES, WHETHER OR NOT SHOWN OR DETAILED AND INSTALLED BY ANY OTHER CONTRACT. RESTORATION OF UTILITIES DAMAGED BY THE CONTRACTOR SHALL BE AT THE CONTRACTOR'S EXPENSE.
- THOROUGHLY REVIEW THE SITE CONDITIONS, DRAWINGS, AND TECHNICAL SPECIFICATIONS PRIOR TO CONSTRUCTION. COMPLETE THE WORK OF THIS PROJECT IN ACCORDANCE WITH APPROVED DRAWINGS.
- ANYTHING MENTIONED IN THE TECHNICAL SPECIFICATIONS AND NOT SHOWN ON THE DRAWINGS, OR SHOWN ON THE DRAWINGS AND NOT MENTIONED IN THE TECHNICAL SPECIFICATIONS SHALL BE OF LIKE EFFECT AS IF SHOWN ON OR MENTIONED IN BOTH.
- CONSTRUCTION INSTALLATION, MATERIALS, TESTING AND INSPECTION SHALL COMPLY WITH APPLICABLE CODES, ORDINANCES, AND SPECS.
- TAKE NECESSARY STEPS TO PROTECT AND MAINTAIN ALL FINISHED WORK FOR THE DURATION OF THE CONTRACT UNTIL FINAL ACCEPTANCE.
- THESE DRAWINGS DO NOT SPECIFY SAFETY MATERIALS, EQUIPMENT, METHODS OR SEQUENCING TO PROTECT PERSONS AND PROPERTY. DIRECT AND IMPLEMENT SAFETY OPERATIONS AND PROCEDURES TO PROTECT THE OWNER, OTHER CONTRACTORS, THE PUBLIC, AND OTHERS FOR THE DURATION OF THE CONTRACT.
- NOTES AND DETAILS ON SPECIFIC DRAWINGS TAKE PRECEDENCE OVER GENERAL NOTES AND TYPICAL DETAILS.
- OBTAIN NECESSARY PERMITS FROM ALL JURISDICTIONS AS REQUIRED TO CONSTRUCT THE WORK OF THIS PROJECT.
- THE WORK OF THIS CONTRACT WILL NOT BE CONSIDERED COMPLETE UNTIL ALL AREAS HAVE BEEN CLEANED OF ALL DIRT AND DEBRIS AND ALL DAMAGED ITEMS ARE REPAIRED.

REV. NO.	DATE	DESCRIPTION	BY

MOORE IACOFANO GOLTSMAN, INC.  
 317 LEXINGTON AVENUE, SUITE 2  
 SAN ANTONIO, TEXAS, CA 78215 TEL 210-600-9990  
 www.migcom.com

**PAPE-DAWSON ENGINEERS**  
 SAN ANTONIO | AUSTIN | HOUSTON | FORT WORTH | DALLAS  
 3600 HW LOOP 416 | SAN ANTONIO, TX 78219 | 210.378.9999  
 TEXAS ENGINEERING FIRM #479 | TEXAS SURVEYING FIRM #10000000

CITY OF SAN ANTONIO  
**PUBLIC WORKS DEPARTMENT**

DOLOROSA

LANDSCAPE SCHEDULE AND NOTES

DESIGN	CHECKED	DRAWN	PROJECT NO.	SUBMITTAL	SHEET NO.
RD/AM	RD/AM	TM/RD	23-03763	70%	315

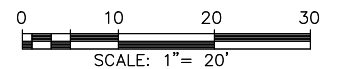
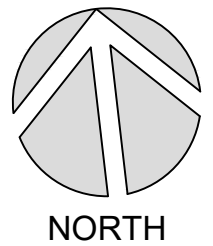
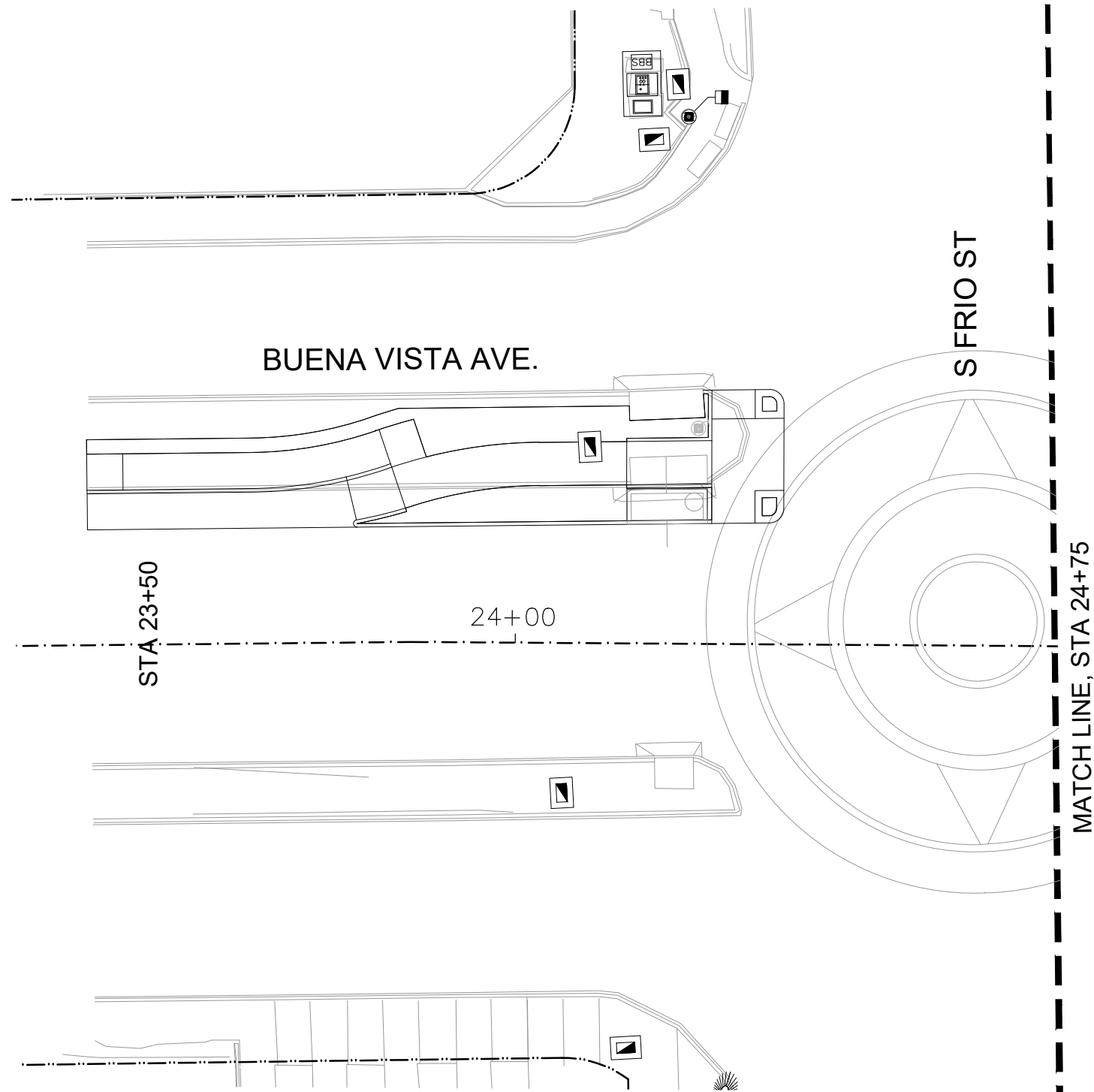

REV. NO.	DATE	DESCRIPTION	BY

**MOORE IACOFANO GOLTSMAN, INC.**  
 317 LEXINGTON AVENUE, SUITE 2  
 SAN ANTONIO, TEXAS, CA 78215  
 TEL 210-600-9990  
 www.migcom.com



SAN ANTONIO | AUSTIN | HOUSTON | FORT WORTH | DALLAS  
 3800 HWY 190P-419 | SAN ANTONIO, TX 78213 | 210.375.9999  
 TEXAS ENGINEERING FIRM #479 | TEXAS SURVEYING FIRM #10028800



CITY OF SAN ANTONIO  
**PUBLIC WORKS DEPARTMENT**

DOLOROSA

**LANDSCAPE SITE PLAN**

STA 23+50 TO STA 24+75

SHEET 1 OF 16

DESIGN	CHECKED	DRAWN	PROJECT NO.	SUBMITTAL	SHEET NO.
RD/AM	RD/AM	TM/RD	23-03763	70%	316

**LEGEND**

- |      |  |                             |  |   |      |                 |  |      |                      |                    |                              |  |                     |                              |
|------|--|-----------------------------|--|---|------|-----------------|--|------|----------------------|--------------------|------------------------------|--|---------------------|------------------------------|
| P-01 |  | CONC. ACCENT PLAZA W/ GRECA |  | CONCRETE PAVING CYCLE TRACK (SEE CIVIL) |      | VIA BUS SHELTER | A-05                                     |      | BOLLARD, 4" DIAMETER |                    | NEW TREE (SEE PLANTING PLAN) |  | CENTER STATION LINE |                              |
| P-02 |  | PORPHYRY PAVING (WALKWAY)   |  | EXISTING LANDSCAPE TO REMAIN            | A-01 |                 | CHAIR (BACKED AND BACKLESS)              | A-06 |                      | REMOVABLE BOLLARDS |                              | EXISTING TREE TO REMAIN                |                     | PROPERTY LINE / RIGHT OF WAY |
| P-05 |  | CONCRETE PAVING (SIDEWALK)  |  | EXISTING PAVING TO REMAIN               | A-02 |                 | BENCH (LIME-STONE BLOCK)                 | A-08 |                      | BICYCLE RACK       |                              | STRUCTURAL SOIL (SEE PLANTING)         |                     | LIMIT OF WORK                |
| P-06 |  | PORPHYRY PAVING (ROADWAY)   |  | UNIT PAVERS TYPE 2 (MARKET SQUARE)      |      |                 | PEDESTRIAN LIGHT (SEE ILLUMINATION PLAN) | A-09 |                      | TRASH / RECYCLING  |                              | REFER SAN SABA AND SANTA ROSA DRAWINGS |                     | MATCH LINE                   |
| P-09 |  | CRUSHED STONE MULCH         |  | PLANTING AREA (SEE PLANTING)            |      |                 | REMOVABLE PLANTERS                       | A-10 |                      |                    |                              |  |                     |                              |

NOTE: SEE SCHEDULE SHEET XXX FOR PAVING AND AMENITIES INFORMATION; FOR CLARITY, ALL UTILITIES ARE NOT REFERENCED ON THIS PLAN. SEE UTILITY LAYOUT PLANS FOR ALL UTILITIES.

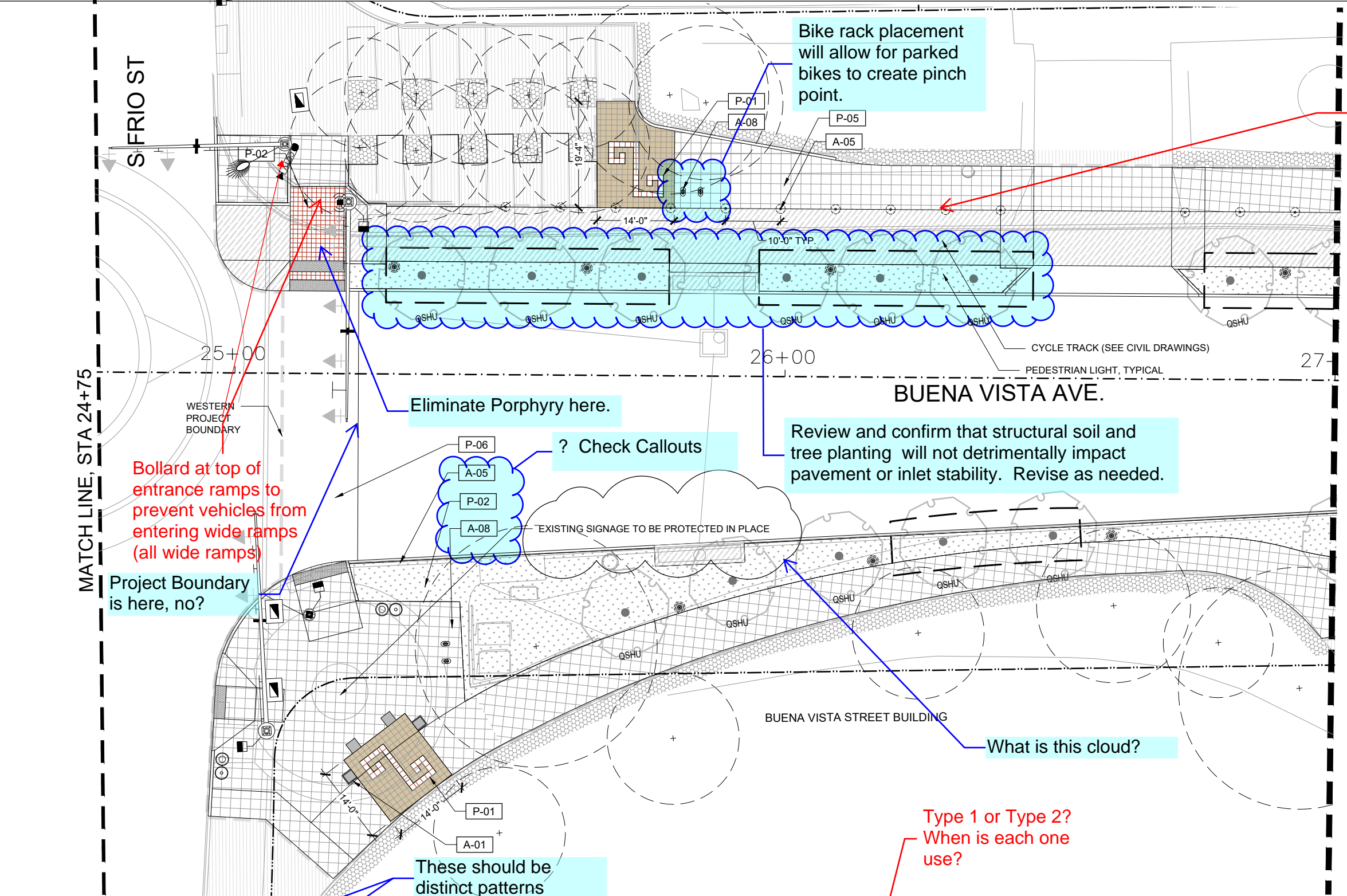

Bike rack placement will allow for parked bikes to create pinch point.

Is there enough room for a paverband to help differentiate between sidewalk and cycletrack and make more visibly appealing and allow for a slight buffer between bikes and peds?

Include quantity boxes for all sheets in 95% submittal.

Eliminate Porphyry here.

Review and confirm that structural soil and tree planting will not detrimentally impact pavement or inlet stability. Revise as needed.

? Check Callouts

Bollard at top of entrance ramps to prevent vehicles from entering wide ramps (all wide ramps)

Project Boundary is here, no?

What is this cloud?

These should be distinct patterns

Type 1 or Type 2? When is each one use?

LEGEND

P-01	CONC. ACCENT PLAZA W/ GRECA	CONCRETE PAVING CYCLE TRACK (SEE CIVIL)	VIA BUS SHELTER	A-05	BOLLARD, 4" DIAMETER	NEW TREE (SEE PLANTING PLAN)	CENTER STATION LINE
P-02	PORPHYRY PAVING (WALKWAY)	EXISTING LANDSCAPE TO REMAIN	A-01	CHAIR (BACKED AND BACKLESS)	A-06	REMOVABLE BOLLARDS	PROPERTY LINE / RIGHT OF WAY
P-05	CONCRETE PAVING (SIDEWALK)	EXISTING PAVING TO REMAIN	A-02	BENCH (LIME-STONE BLOCK)	A-08	BICYCLE RACK	LIMIT OF WORK
P-06	PORPHYRY PAVING (ROADWAY)	UNIT PAVERS TYPE 2 (MARKET SQUARE)		PEDESTRIAN LIGHT (SEE ILLUMINATION PLAN)	A-09	TRASH / RECYCLING	MATCH LINE
P-09	CRUSHED STONE MULCH	PLANTING AREA (SEE PLANTING)			A-10	REMOVABLE PLANTERS	

Adjust scale to make this visible.

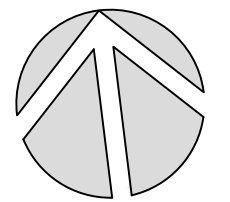

NORTH

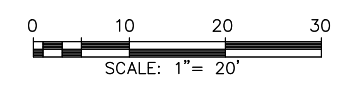

REV. NO.	DATE	DESCRIPTION	BY

MOORE IACOFANO GOLTSMAN, INC.  
317 LEXINGTON AVENUE, SUITE 2  
SAN ANTONIO, TEXAS, CA 78215  
TEL 210-600-9990  
www.migcom.com



SAN ANTONIO | AUSTIN | HOUSTON | FORT WORTH | DALLAS  
3800 HWY 150P-410 | SAN ANTONIO, TX 78213 | 210.375.9999  
TEXAS ENGINEERING FIRM #479 | TEXAS SURVEYING FIRM #10028990



CITY OF SAN ANTONIO  
PUBLIC WORKS DEPARTMENT

DOLOROSA  
LANDSCAPE SITE PLAN

STA 24+75 TO STA 27+00

SHEET 2 OF 16

DESIGN	CHECKED	DRAWN	PROJECT NO.	SUBMITTAL	SHEET NO.
RD/AM	RD/AM	TM/RD	23-03763	70%	317

NOTE: SEE SCHEDULE SHEET XXX FOR PAVING AND AMENITIES INFORMATION; FOR CLARITY, ALL UTILITIES ARE NOT REFERENCED ON THIS PLAN. SEE UTILITY LAYOUT PLANS FOR ALL UTILITIES.

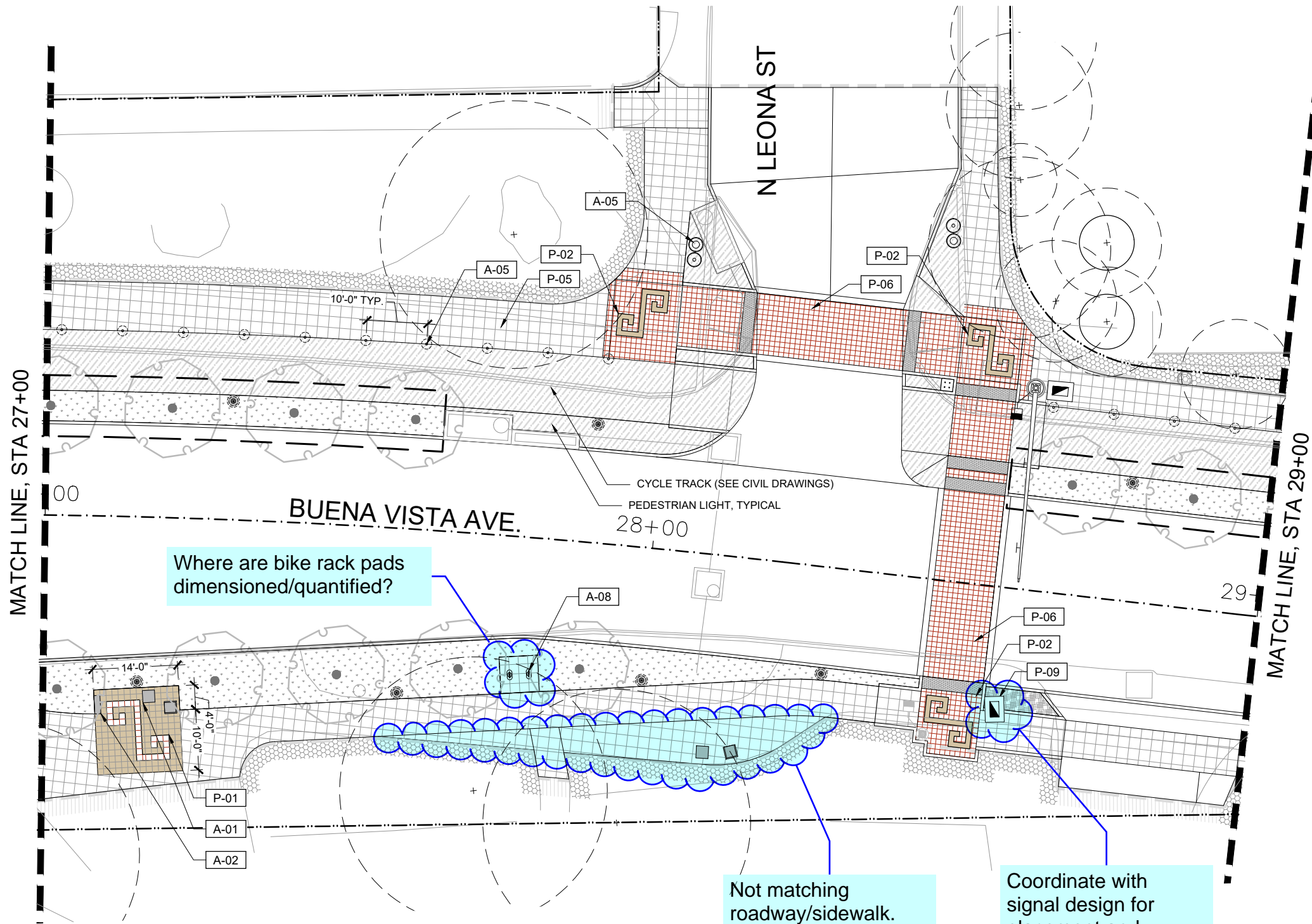

Where are bike rack pads dimensioned/quantified?

Not matching roadway/sidewalk.

Coordinate with signal design for placement and alignment.

**LEGEND**

P-01	CONC. ACCENT PLAZA W/ GRECA	CONCRETE PAVING CYCLE TRACK (SEE CIVIL)	VIA BUS SHELTER	A-05	BOLLARD, 4" DIAMETER	NEW TREE (SEE PLANTING PLAN)	CENTER STATION LINE
P-02	PORPHYRY PAVING (WALKWAY)	EXISTING LANDSCAPE TO REMAIN	A-01	CHAIR (BACKED AND BACKLESS)	A-06	REMOVABLE BOLLARDS	PROPERTY LINE / RIGHT OF WAY
P-05	CONCRETE PAVING (SIDEWALK)	EXISTING PAVING TO REMAIN	A-02	BENCH (LIME-STONE BLOCK)	A-08	BICYCLE RACK	LIMIT OF WORK
P-06	PORPHYRY PAVING (ROADWAY)	UNIT PAVERS TYPE 2 (MARKET SQUARE)	PEDESTRIAN LIGHT (SEE ILLUMINATION PLAN)	A-09	TRASH / RECYCLING	REFER SAN SABA AND SANTA ROSA DRAWINGS	MATCH LINE
P-09	CRUSHED STONE MULCH	PLANTING AREA (SEE PLANTING)		A-10	REMOVABLE PLANTERS		

NOTE: SEE SCHEDULE SHEET XXX FOR PAVING AND AMENITIES INFORMATION; FOR CLARITY, ALL UTILITIES ARE NOT REFERENCED ON THIS PLAN. SEE UTILITY LAYOUT PLANS FOR ALL UTILITIES.

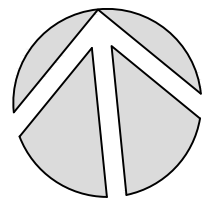

NORTH

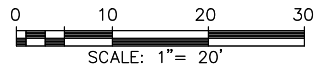

REV. NO.	DATE	DESCRIPTION	BY

MOORE IACOFANO GOLTSMAN, INC.  
317 LEXINGTON AVENUE, SUITE 2  
SAN ANTONIO, TEXAS, CA 78215  
www.migcom.com



SAN ANTONIO | AUSTIN | HOUSTON | FORT WORTH | DALLAS  
3800 HWY 150P-418 | SAN ANTONIO, TX 78213 | 210.375.9999  
TEXAS ENGINEERING FIRM #470 | TEXAS SURVEYING FIRM #10028900



CITY OF SAN ANTONIO  
PUBLIC WORKS DEPARTMENT

DOLOROSA

LANDSCAPE SITE PLAN

STA 27+00 TO STA 29+00

SHEET 3 OF 16

DESIGN	CHECKED	DRAWN	PROJECT NO.	SUBMITTAL	SHEET NO.
RD/AM	RD/AM	TM/RD	23-03763	70%	318

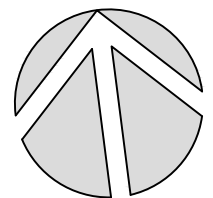
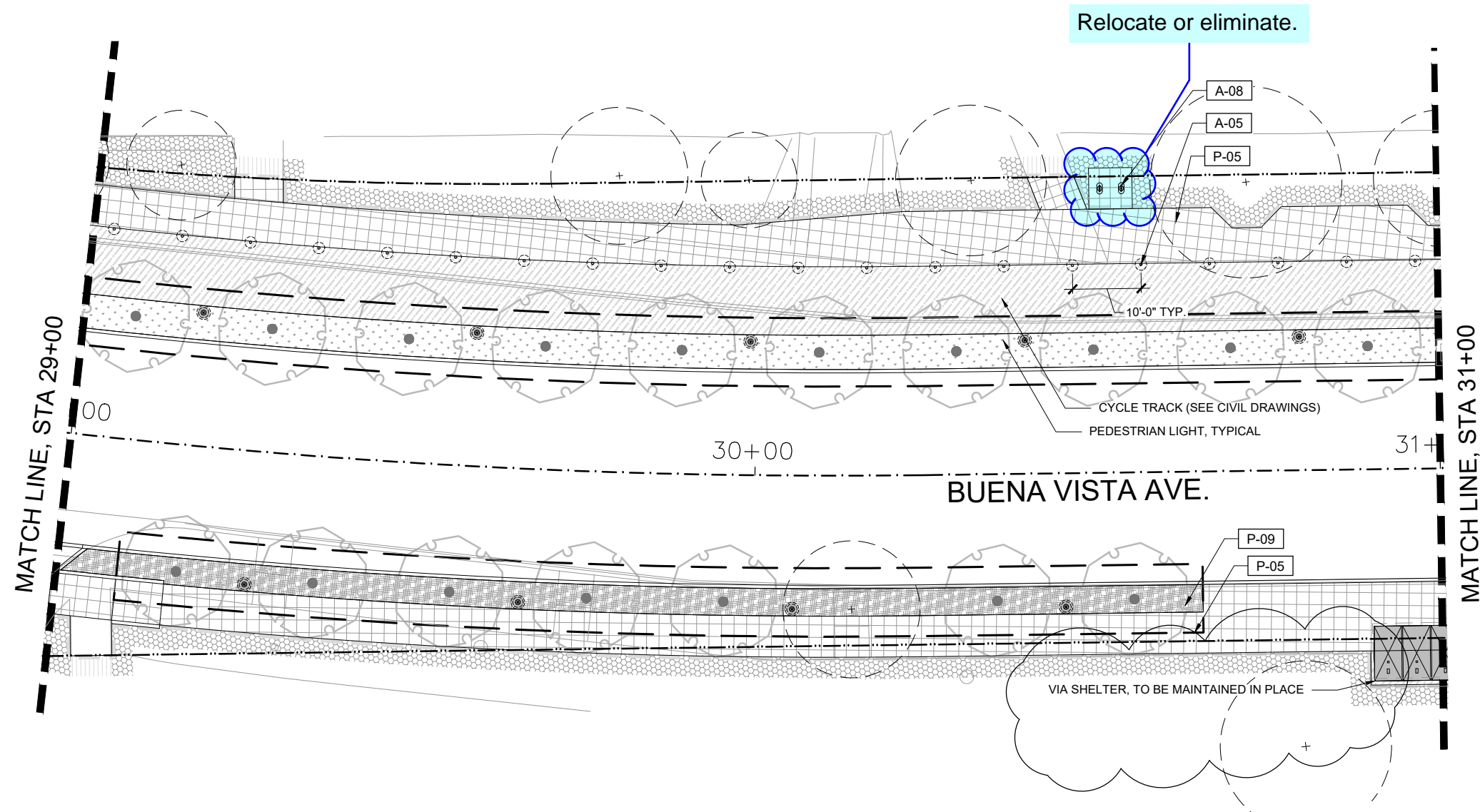

NORTH

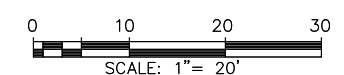

REV. NO.	DATE	DESCRIPTION	BY

**MOORE IACOFANO GOLTSMAN, INC.**  
 317 LEXINGTON AVENUE, SUITE 2  
 SAN ANTONIO, TEXAS, CA 78215  
 TEL 210-600-9990  
 www.migcom.com



SAN ANTONIO | AUSTIN | HOUSTON | FORT WORTH | DALLAS  
 3800 HWY 190P-419 | SAN ANTONIO, TX 78213 | 210.375.9999  
 TEXAS ENGINEERING FIRM #479 | TEXAS SURVEYING FIRM #10028900



CITY OF SAN ANTONIO  
**PUBLIC WORKS DEPARTMENT**

DOLOROSA

**LANDSCAPE SITE PLAN**

STA 29+00 TO STA 31+00

SHEET 4 OF 16

**LEGEND**

P-01	CONC. ACCENT PLAZA W/ GRECA	CONCRETE PAVING CYCLE TRACK (SEE CIVIL)	VIA BUS SHELTER	A-05	BOLLARD, 4" DIAMETER	NEW TREE (SEE PLANTING PLAN)	- - - -	CENTER STATION LINE
P-02	PORPHYRY PAVING (WALKWAY)	EXISTING LANDSCAPE TO REMAIN	A-01	CHAIR (BACKED AND BACKLESS)	A-06	REMOVABLE BOLLARDS	- - - -	PROPERTY LINE / RIGHT OF WAY
P-05	CONCRETE PAVING (SIDEWALK)	EXISTING PAVING TO REMAIN	A-02	BENCH (LIME-STONE BLOCK)	A-08	BICYCLE RACK	- - - -	LIMIT OF WORK
P-06	PORPHYRY PAVING (ROADWAY)	UNIT PAVERS TYPE 2 (MARKET SQUARE)	PEDESTRIAN LIGHT (SEE ILLUMINATION PLAN)	A-09	TRASH / RECYCLING	REFER SAN SABA AND SANTA ROSA DRAWINGS	MATCH LINE	
P-09	CRUSHED STONE MULCH	PLANTING AREA (SEE PLANTING)		A-10	REMOVABLE PLANTERS			

NOTE: SEE SCHEDULE SHEET XXX FOR PAVING AND AMENITIES INFORMATION; FOR CLARITY, ALL UTILITIES ARE NOT REFERENCED ON THIS PLAN. SEE UTILITY LAYOUT PLANS FOR ALL UTILITIES.

DESIGN	CHECKED	DRAWN	PROJECT NO.	SUBMITTAL	SHEET NO.
RD/AM	RD/AM	TM/RD	23-03763	70%	319

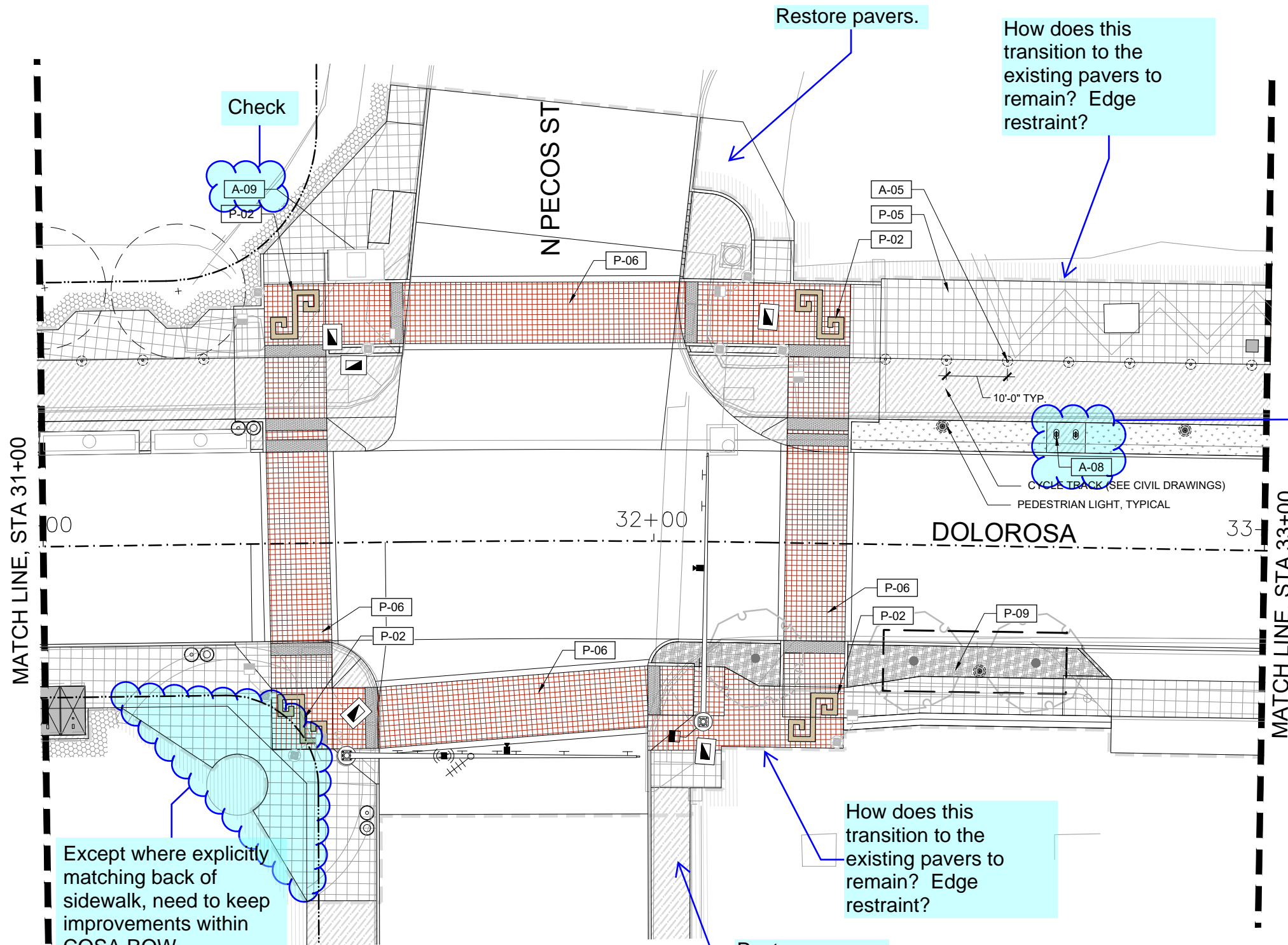

This is not enough room for bike racks

Restore pavers.

How does this transition to the existing pavers to remain? Edge restraint?

How does this transition to the existing pavers to remain? Edge restraint?

Except where explicitly matching back of sidewalk, need to keep improvements within COSA ROW.

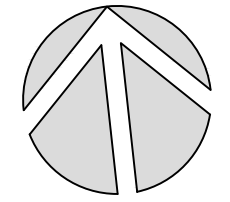

NORTH

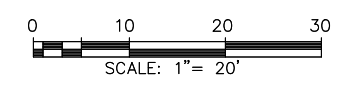

REV. NO.	DATE	DESCRIPTION	BY

MOORE IACOFANO GOLTSMAN, INC.  
317 LEXINGTON AVENUE, SUITE 2  
SAN ANTONIO, TEXAS, CA 78215  
TEL 210-600-9990  
www.migcom.com

**PAPE-DAWSON ENGINEERS**  
SAN ANTONIO | AUSTIN | HOUSTON | FORT WORTH | DALLAS  
3800 HWY 149P-419 | SAN ANTONIO, TX 78213 | 210.375.9999  
TEXAS ENGINEERING FIRM #479 | TEXAS SURVEYING FIRM #10028990

CITY OF SAN ANTONIO  
**PUBLIC WORKS DEPARTMENT**

DOLOROSA  
**LANDSCAPE SITE PLAN**  
STA 31+00 TO STA 33+00  
SHEET 5 OF 16

**LEGEND**

P-01	CONC. ACCENT PLAZA W/ GRECA	CONCRETE PAVING CYCLE TRACK (SEE CIVIL)	VIA BUS SHELTER	A-05	BOLLARD, 4" DIAMETER	NEW TREE (SEE PLANTING PLAN)	CENTER STATION LINE
P-02	PORPHYRY PAVING (WALKWAY)	EXISTING LANDSCAPE TO REMAIN	A-01	CHAIR (BACKED AND BACKLESS)	A-06	EXISTING TREE TO REMAIN	PROPERTY LINE / RIGHT OF WAY
P-05	CONCRETE PAVING (SIDEWALK)	EXISTING PAVING TO REMAIN	A-02	BENCH (LIME-STONE BLOCK)	A-08	BICYCLE RACK	LIMIT OF WORK
P-06	PORPHYRY PAVING (ROADWAY)	UNIT PAVERS TYPE 2 (MARKET SQUARE)	PEDESTRIAN LIGHT (SEE ILLUMINATION PLAN)	A-09	TRASH / RECYCLING	REFER SAN SABA AND SANTA ROSA DRAWINGS	MATCH LINE
P-09	CRUSHED STONE MULCH	PLANTING AREA (SEE PLANTING)		A-10	REMOVABLE PLANTERS		

NOTE: SEE SCHEDULE SHEET XXX FOR PAVING AND AMENITIES INFORMATION; FOR CLARITY, ALL UTILITIES ARE NOT REFERENCED ON THIS PLAN. SEE UTILITY LAYOUT PLANS FOR ALL UTILITIES.

DESIGN	CHECKED	DRAWN	PROJECT NO.	SUBMITTAL	SHEET NO.
RD/AM	RD/AM	TM/RD	23-03763	70%	320

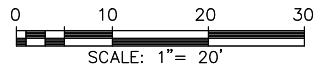
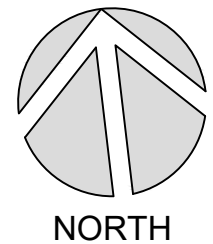
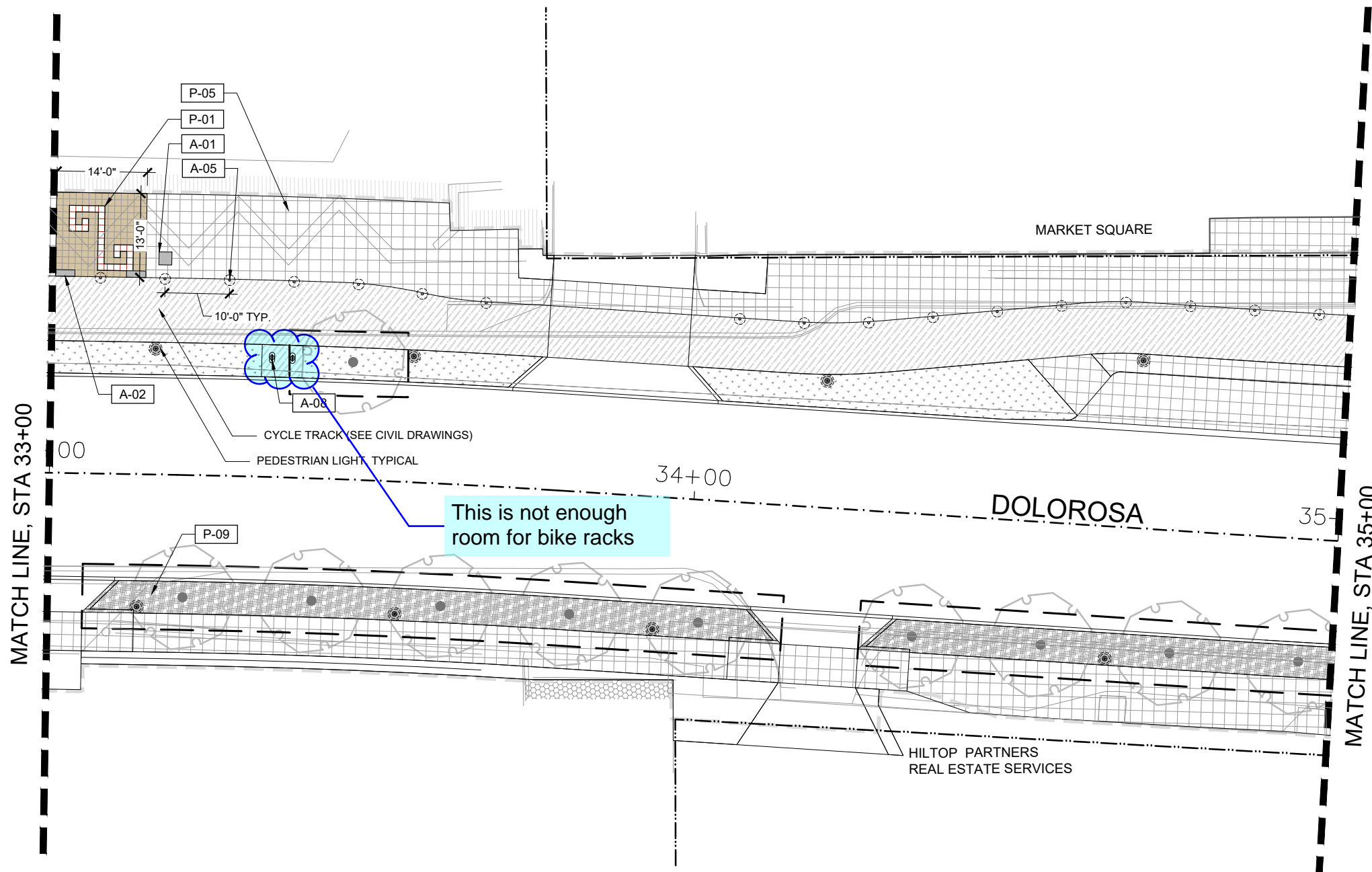

**LEGEND**

P-01	CONC. ACCENT PLAZA W/ GRECA	CONCRETE PAVING CYCLE TRACK (SEE CIVIL)	VIA BUS SHELTER	A-05	BOLLARD, 4" DIAMETER	NEW TREE (SEE PLANTING PLAN)	CENTER STATION LINE
P-02	PORPHYRY PAVING (WALKWAY)	EXISTING LANDSCAPE TO REMAIN	A-01	CHAIR (BACKED AND BACKLESS)	A-06	EXISTING TREE TO REMAIN	PROPERTY LINE / RIGHT OF WAY
P-05	CONCRETE PAVING (SIDEWALK)	EXISTING PAVING TO REMAIN	A-02	BENCH (LIME-STONE BLOCK)	A-08	BICYCLE RACK	LIMIT OF WORK
P-06	PORPHYRY PAVING (ROADWAY)	UNIT PAVERS TYPE 2 (MARKET SQUARE)	PEDESTRIAN LIGHT (SEE ILLUMINATION PLAN)	A-09	TRASH / RECYCLING	REFER SAN SABA AND SANTA ROSA DRAWINGS	MATCH LINE
P-09	CRUSHED STONE MULCH	PLANTING AREA (SEE PLANTING)	A-10	REMOVABLE PLANTERS	NOTE: SEE SCHEDULE SHEET XXX FOR PAVING AND AMENITIES INFORMATION; FOR CLARITY, ALL UTILITIES ARE NOT REFERENCED ON THIS PLAN. SEE UTILITY LAYOUT PLANS FOR ALL UTILITIES.		

REV. NO.	DATE	DESCRIPTION	BY

**MIG** MOORE IACOFANO GOLTSMAN, INC.  
 317 LEXINGTON AVENUE, SUITE 2  
 SAN ANTONIO, TEXAS, CA 78215  
 TEL 210-600-9990  
 www.migcom.com

**Pape-Dawson ENGINEERS**  
 SAN ANTONIO | AUSTIN | HOUSTON | FORT WORTH | DALLAS  
 3800 HWY 149P-419 | SAN ANTONIO, TX 78213 | 210.375.9999  
 TEXAS ENGINEERING FIRM #479 | TEXAS SURVEYING FIRM #10028990

CITY OF SAN ANTONIO  
**PUBLIC WORKS DEPARTMENT**

DOLOROSA  
 LANDSCAPE SITE PLAN  
 STA 33+00 TO STA 35+00  
 SHEET 6 OF 16

DESIGN	CHECKED	DRAWN	PROJECT NO.	SUBMITTAL	SHEET NO.
RD/AM	RD/AM	TM/RD	23-03763	70%	321

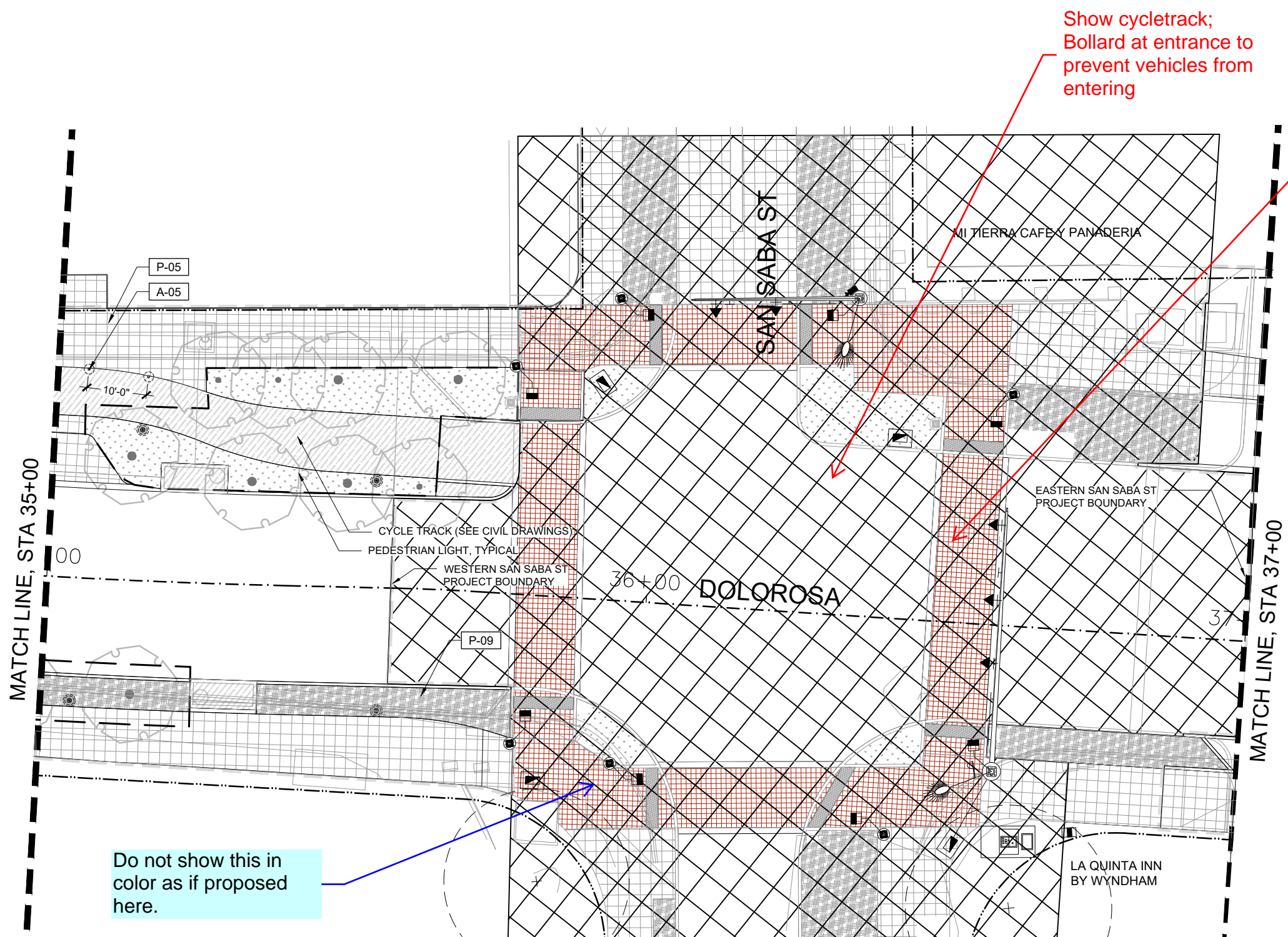

Show cycletrack;  
Bollard at entrance to  
prevent vehicles from  
entering

Paver crosswalks are  
not visible at night or  
rainy days, use  
standard details; In  
general brick should  
not be used in  
crosswalks (all ped  
ramps)



A crosswalk in Paris with cobblestones before the  
painted bars – alerting drivers that they should come to  
a stop.

Pavers can be used  
to supplement a  
marked crosswalk but  
not in the crosswalk

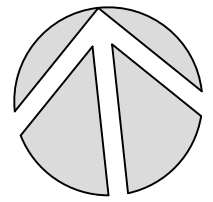

NORTH

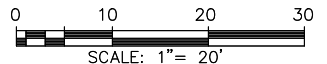

LEGEND

P-01	CONC. ACCENT PLAZA W/ GRECA	CONCRETE PAVING CYCLE TRACK (SEE CIVIL)	VIA BUS SHELTER	A-05	BOLLARD, 4" DIAMETER	NEW TREE (SEE PLANTING PLAN)	CENTER STATION LINE
P-02	PORPHYRY PAVING (WALKWAY)	EXISTING LANDSCAPE TO REMAIN	A-01	CHAIR (BACKED AND BACKLESS)	A-06	EXISTING TREE TO REMAIN	PROPERTY LINE / RIGHT OF WAY
P-05	CONCRETE PAVING (SIDEWALK)	EXISTING PAVING TO REMAIN	A-02	BENCH (LIME-STONE BLOCK)	A-08	STRUCTURAL SOIL (SEE PLANTING)	LIMIT OF WORK
P-06	PORPHYRY PAVING (ROADWAY)	UNIT PAVERS TYPE 2 (MARKET SQUARE)	PEDESTRIAN LIGHT (SEE ILLUMINATION PLAN)	A-09	TRASH / RECYCLING	REFER SAN SABA AND SANTA ROSA DRAWINGS	MATCH LINE
P-09	CRUSHED STONE MULCH	PLANTING AREA (SEE PLANTING)	A-10	REMOVABLE PLANTERS			

NOTE: SEE SCHEDULE SHEET XXX FOR PAVING AND AMENITIES INFORMATION; FOR CLARITY, ALL UTILITIES ARE NOT REFERENCED ON THIS PLAN. SEE UTILITY LAYOUT PLANS FOR ALL UTILITIES.

REV. NO.	DATE	DESCRIPTION	BY

MOORE IACOFANO GOLTSMAN, INC.  
317 LEXINGTON AVENUE, SUITE 2  
SAN ANTONIO, TEXAS, CA 78215  
TEL 210-600-9990  
www.migcom.com

**PAPE-DAWSON ENGINEERS**  
SAN ANTONIO | AUSTIN | HOUSTON | FORT WORTH | DALLAS  
3800 HWY 150P-410 | SAN ANTONIO, TX 78213 | 310.375.9999  
TEXAS ENGINEERING FIRM #470 | TEXAS SURVEYING FIRM #1002890

CITY OF SAN ANTONIO  
**PUBLIC WORKS DEPARTMENT**

DOLOROSA  
**LANDSCAPE SITE PLAN**  
STA 35+00 TO STA 37+00  
SHEET 7 OF 16

DESIGN	CHECKED	DRAWN	PROJECT NO.	SUBMITTAL	SHEET NO.
RD/AM	RD/AM	TM/RD	23-03763	70%	322



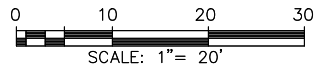
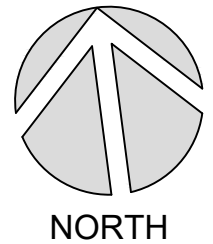
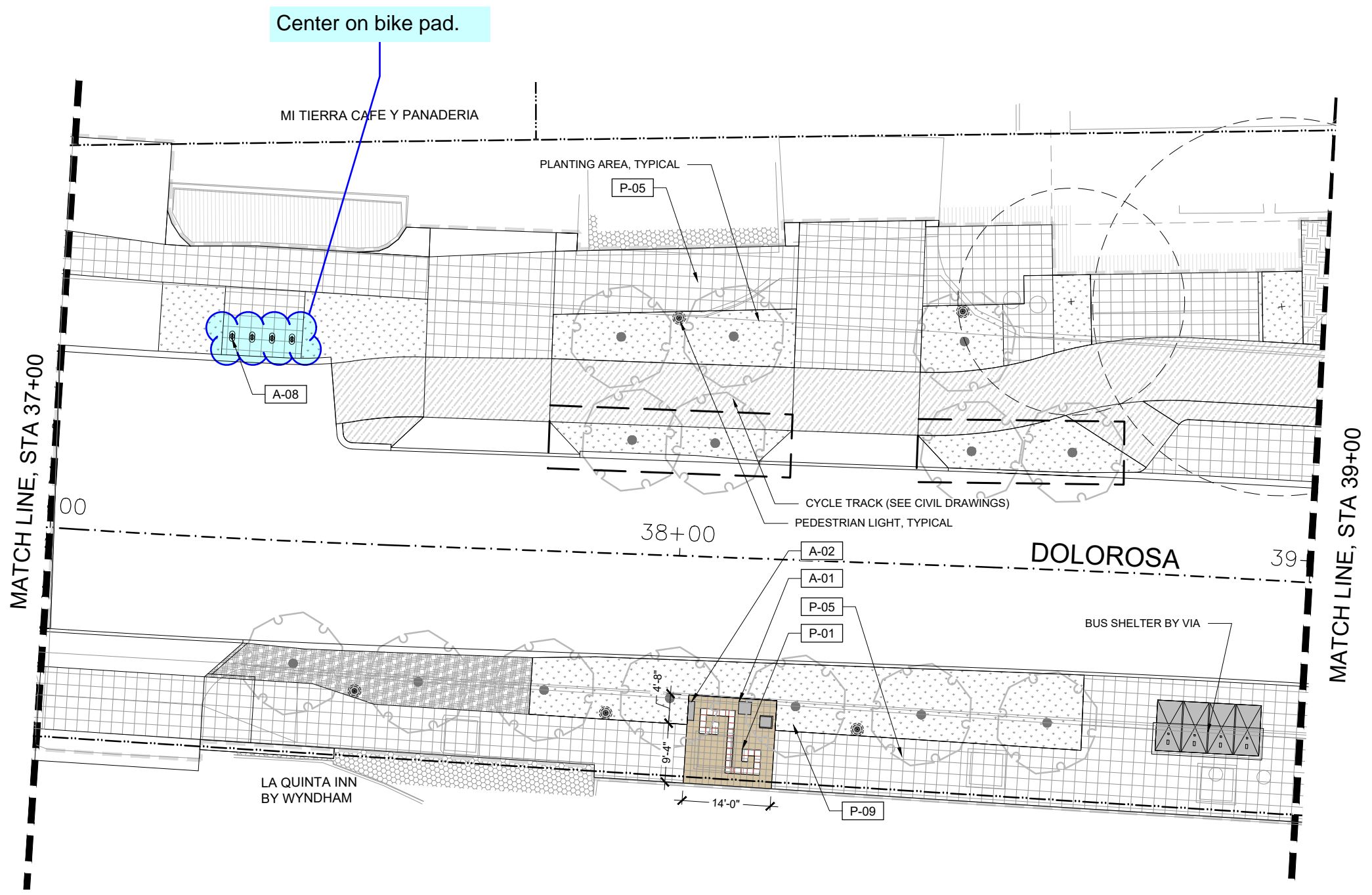

**LEGEND**

P-01	CONC. ACCENT PLAZA W/ GRECA	CONCRETE PAVING CYCLE TRACK (SEE CIVIL)	VIA BUS SHELTER	A-05	BOLLARD, 4" DIAMETER	NEW TREE (SEE PLANTING PLAN)	- - - -	CENTER STATION LINE	
P-02	PORPHYRY PAVING (WALKWAY)	EXISTING LANDSCAPE TO REMAIN	A-01	CHAIR (BACKED AND BACKLESS)	A-06	REMOVABLE BOLLARDS	EXISTING TREE TO REMAIN	- - - -	PROPERTY LINE / RIGHT OF WAY
P-05	CONCRETE PAVING (SIDEWALK)	EXISTING PAVING TO REMAIN	A-02	BENCH (LIME-STONE BLOCK)	A-08	BICYCLE RACK	- - - -	STRUCTURAL SOIL (SEE PLANTING)	
P-06	PORPHYRY PAVING (ROADWAY)	UNIT PAVERS TYPE 2 (MARKET SQUARE)		PEDESTRIAN LIGHT (SEE ILLUMINATION PLAN)	A-09	TRASH / RECYCLING	REFER SAN SABA AND SANTA ROSA DRAWINGS	- - - -	LIMIT OF WORK
P-09	CRUSHED STONE MULCH	PLANTING AREA (SEE PLANTING)			A-10	REMOVABLE PLANTERS	MATCH LINE		

NOTE: SEE SCHEDULE SHEET XXX FOR PAVING AND AMENITIES INFORMATION; FOR CLARITY, ALL UTILITIES ARE NOT REFERENCED ON THIS PLAN. SEE UTILITY LAYOUT PLANS FOR ALL UTILITIES.

REV. NO.	DATE	DESCRIPTION	BY

**MIG** MOORE IACOFANO GOLTSMAN, INC.  
 317 LEXINGTON AVENUE, SUITE 2  
 SAN ANTONIO, TEXAS, CA 78215  
 TEL 210-600-9990  
 www.migcom.com

**PAPE-DAWSON ENGINEERS**  
 SAN ANTONIO | AUSTIN | HOUSTON | FORT WORTH | DALLAS  
 3600 HWY 190P-419 | SAN ANTONIO, TX 78213 | 210.375.9999  
 TEXAS ENGINEERING FIRM #479 | TEXAS SURVEYING FIRM #10028990

CITY OF SAN ANTONIO  
**PUBLIC WORKS DEPARTMENT**

DOLOROSA  
 LANDSCAPE SITE PLAN  
 STA 37+00 TO STA 39+00  
 SHEET 8 OF 16

DESIGN	CHECKED	DRAWN	PROJECT NO.	SUBMITTAL	SHEET NO.
RD/AM	RD/AM	TM/RD	23-03763	70%	323

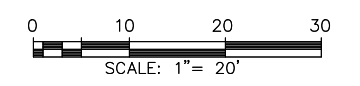
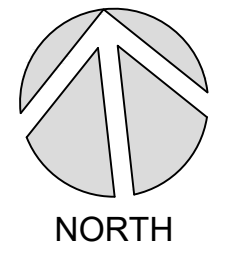
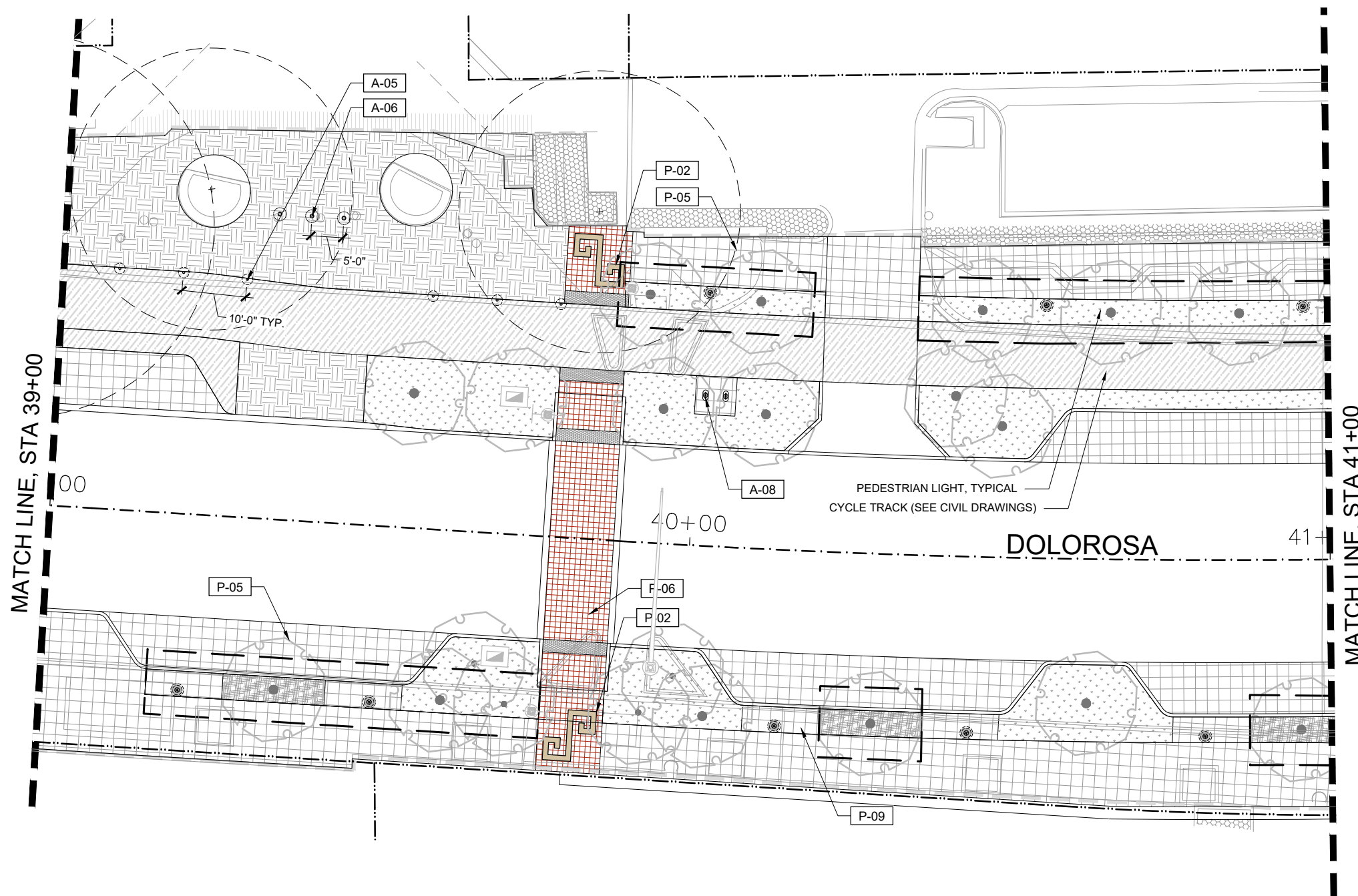

**LEGEND**

P-01	CONC. ACCENT PLAZA W/ GRECA	CONCRETE PAVING CYCLE TRACK (SEE CIVIL)	VIA BUS SHELTER	A-05	BOLLARD, 4" DIAMETER	NEW TREE (SEE PLANTING PLAN)	- - - -	CENTER STATION LINE	
P-02	PORPHYRY PAVING (WALKWAY)	EXISTING LANDSCAPE TO REMAIN	A-01	CHAIR (BACKED AND BACKLESS)	A-06	REMOVABLE BOLLARDS	EXISTING TREE TO REMAIN	- - - -	PROPERTY LINE / RIGHT OF WAY
P-05	CONCRETE PAVING (SIDEWALK)	EXISTING PAVING TO REMAIN	A-02	BENCH (LIME-STONE BLOCK)	A-08	BICYCLE RACK	- - - -	STRUCTURAL SOIL (SEE PLANTING)	
P-06	PORPHYRY PAVING (ROADWAY)	UNIT PAVERS TYPE 2 (MARKET SQUARE)		PEDESTRIAN LIGHT (SEE ILLUMINATION PLAN)	A-09	TRASH / RECYCLING	REFER SAN SABA AND SANTA ROSA DRAWINGS	- - - -	LIMIT OF WORK
P-09	CRUSHED STONE MULCH	PLANTING AREA (SEE PLANTING)			A-10	REMOVABLE PLANTERS	MATCH LINE		

NOTE: SEE SCHEDULE SHEET XXX FOR PAVING AND AMENITIES INFORMATION; FOR CLARITY, ALL UTILITIES ARE NOT REFERENCED ON THIS PLAN. SEE UTILITY LAYOUT PLANS FOR ALL UTILITIES.

REV. NO.	DATE	DESCRIPTION	BY

MOORE IACOFANO GOLTSMAN, INC.  
317 LEXINGTON AVENUE, SUITE 2  
SAN ANTONIO, TEXAS, CA 78215  
TEL 210-600-9990  
www.migcom.com

**PAPE-DAWSON ENGINEERS**  
SAN ANTONIO | AUSTIN | HOUSTON | FORT WORTH | DALLAS  
3600 HWY 150P-410 | SAN ANTONIO, TX 78219 | 210.378.9999  
TEXAS ENGINEERING FIRM #470 | TEXAS SURVEYING FIRM #10000000

CITY OF SAN ANTONIO  
**PUBLIC WORKS DEPARTMENT**

DOLOROSA  
**LANDSCAPE SITE PLAN**  
STA 39+00 TO STA 41+00  
SHEET 9 OF 16

DESIGN	CHECKED	DRAWN	PROJECT NO.	SUBMITTAL	SHEET NO.
RD/AM	RD/AM	TM/RD	23-03763	70%	324

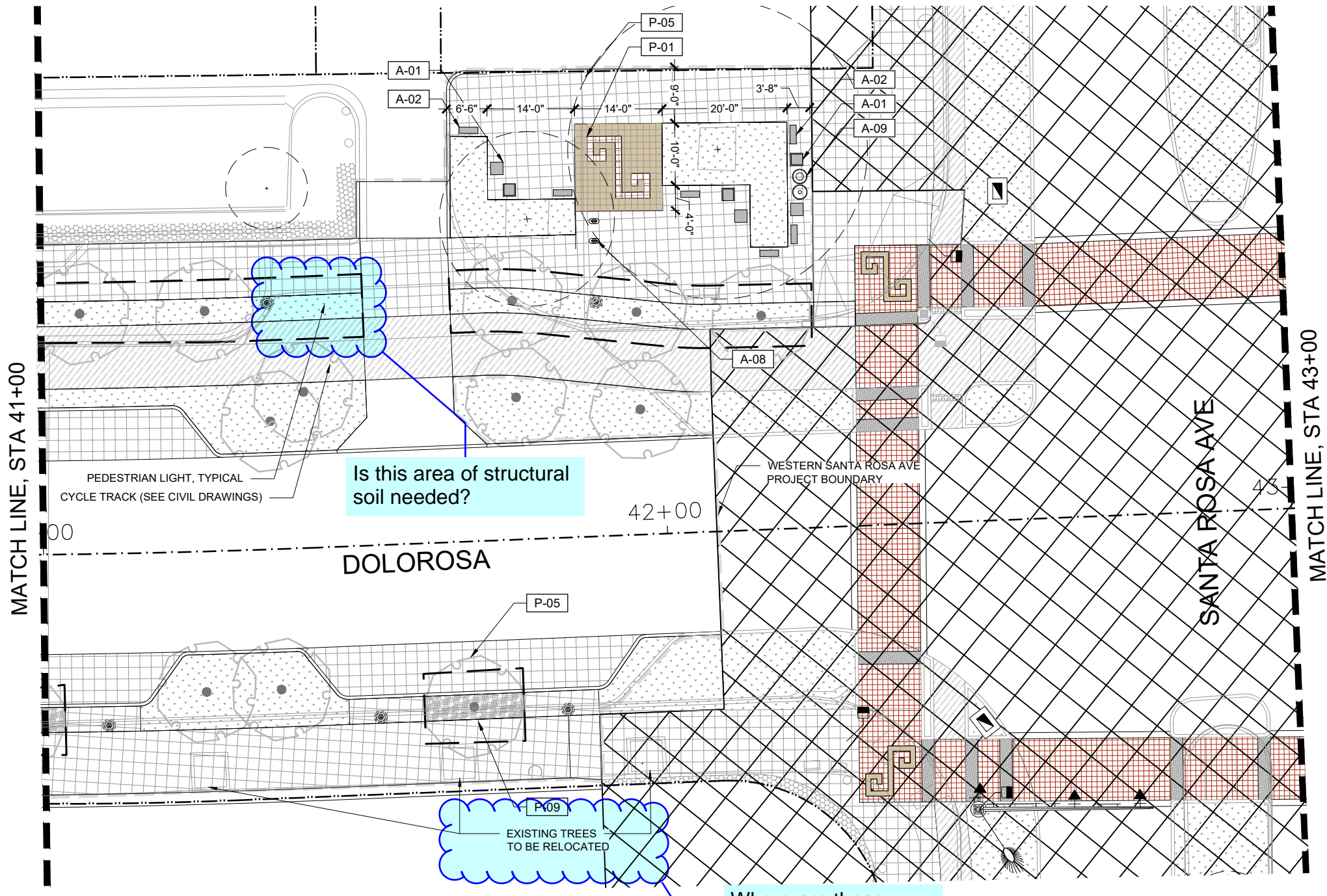

Is this area of structural soil needed?

EXISTING TREES TO BE RELOCATED

Where are these trees to be relocated and how is this paid?

**LEGEND**

P-01	CONC. ACCENT PLAZA W/ GRECA	CONCRETE PAVING CYCLE TRACK (SEE CIVIL)	VIA BUS SHELTER	A-05	BOLLARD, 4" DIAMETER	NEW TREE (SEE PLANTING PLAN)	CENTER STATION LINE
P-02	PORPHYRY PAVING (WALKWAY)	EXISTING LANDSCAPE TO REMAIN	A-01	CHAIR (BACKED AND BACKLESS)	A-06	EXISTING TREE TO REMAIN	PROPERTY LINE / RIGHT OF WAY
P-05	CONCRETE PAVING (SIDEWALK)	EXISTING PAVING TO REMAIN	A-02	BENCH (LIME-STONE BLOCK)	A-08	BICYCLE RACK	LIMIT OF WORK
P-06	PORPHYRY PAVING (ROADWAY)	UNIT PAVERS TYPE 2 (MARKET SQUARE)		PEDESTRIAN LIGHT (SEE ILLUMINATION PLAN)	A-09	TRASH / RECYCLING	MATCH LINE
P-09	CRUSHED STONE MULCH	PLANTING AREA (SEE PLANTING)		A-10	REMOVABLE PLANTERS	REFER SAN SABA AND SANTA ROSA DRAWINGS	

NOTE: SEE SCHEDULE SHEET XXX FOR PAVING AND AMENITIES INFORMATION; FOR CLARITY, ALL UTILITIES ARE NOT REFERENCED ON THIS PLAN. SEE UTILITY LAYOUT PLANS FOR ALL UTILITIES.

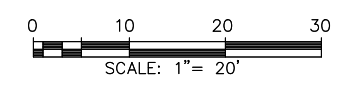
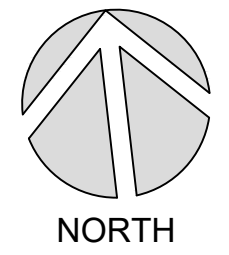

REV. NO.	DATE	DESCRIPTION	BY

**MIG** MOORE IACOFANO GOLTSMAN, INC.  
 317 LEXINGTON AVENUE, SUITE 2  
 SAN ANTONIO, TEXAS, CA 78215  
 TEL 210-600-9990  
 www.migcom.com



SAN ANTONIO | AUSTIN | HOUSTON | FORT WORTH | DALLAS  
 3800 NW LOOP 419 | SAN ANTONIO, TX 78219 | 310.375.9999  
 TEXAS ENGINEERING FIRM #479 | TEXAS SURVEYING FIRM #10028990



DOLOROSA  
**LANDSCAPE SITE PLAN**

STA 41+00 TO STA 43+00

SHEET 10 OF 16

DESIGN	CHECKED	DRAWN	PROJECT NO.	SUBMITTAL	SHEET NO.
RD/AM	RD/AM	TM/RD	23-03763	70%	325

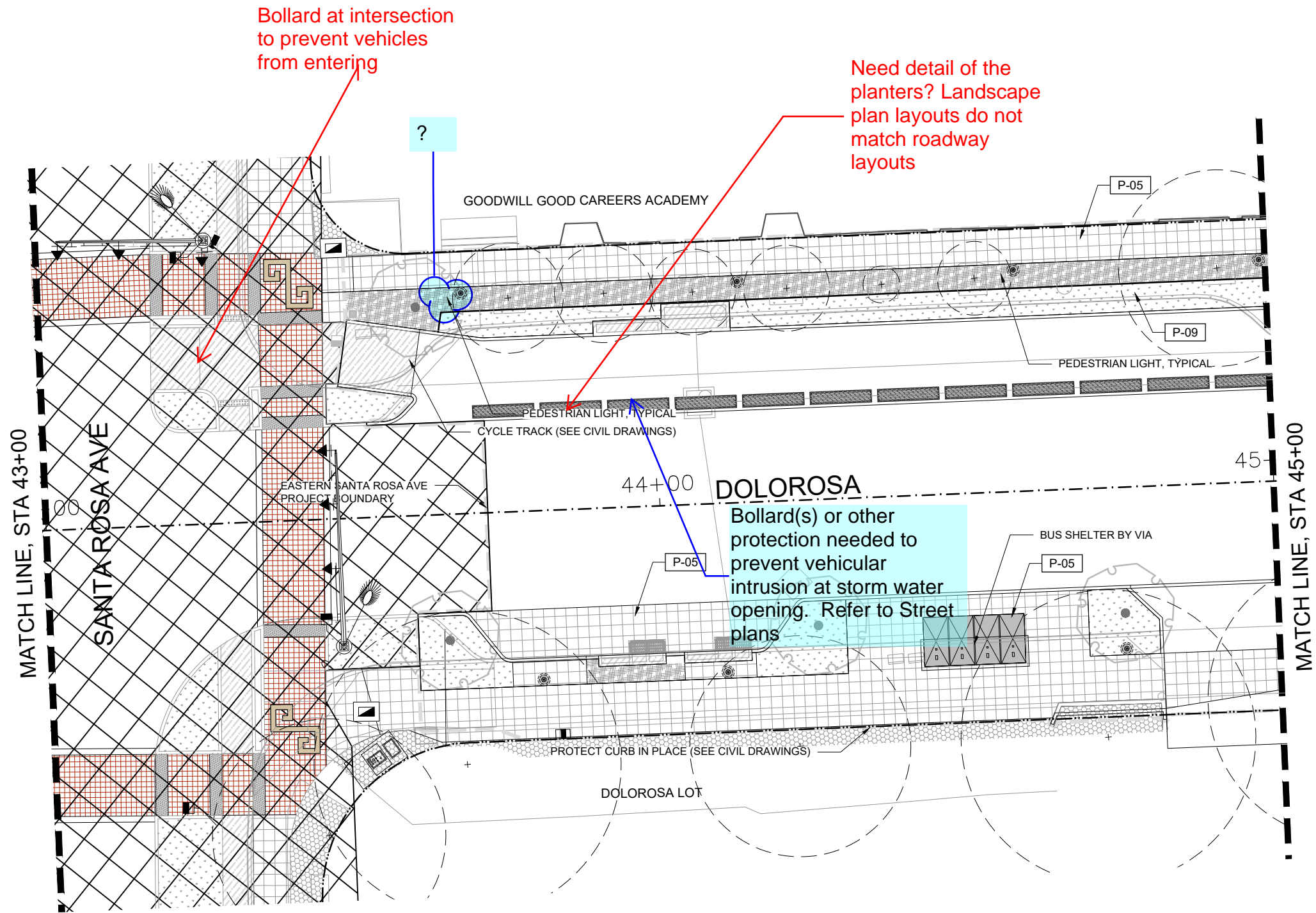

Bollard at intersection to prevent vehicles from entering

Need detail of the planters? Landscape plan layouts do not match roadway layouts

Bollard(s) or other protection needed to prevent vehicular intrusion at storm water opening. Refer to Street plans

**LEGEND**

P-01	CONC. ACCENT PLAZA W/ GRECA	CONCRETE PAVING CYCLE TRACK (SEE CIVIL)	VIA BUS SHELTER	A-05	BOLLARD, 4" DIAMETER	NEW TREE (SEE PLANTING PLAN)	CENTER STATION LINE
P-02	PORPHYRY PAVING (WALKWAY)	EXISTING LANDSCAPE TO REMAIN	A-01	CHAIR (BACKED AND BACKLESS)	A-06	REMOVABLE BOLLARDS	PROPERTY LINE / RIGHT OF WAY
P-05	CONCRETE PAVING (SIDEWALK)	EXISTING PAVING TO REMAIN	A-02	BENCH (LIME-STONE BLOCK)	A-08	BICYCLE RACK	LIMIT OF WORK
P-06	PORPHYRY PAVING (ROADWAY)	UNIT PAVERS TYPE 2 (MARKET SQUARE)	PEDESTRIAN LIGHT (SEE ILLUMINATION PLAN)	A-09	TRASH / RECYCLING	REFER SAN SABA AND SANTA ROSA DRAWINGS	MATCH LINE
P-09	CRUSHED STONE MULCH	PLANTING AREA (SEE PLANTING)		A-10	REMOVABLE PLANTERS		

NOTE: SEE SCHEDULE SHEET XXX FOR PAVING AND AMENITIES INFORMATION; FOR CLARITY, ALL UTILITIES ARE NOT REFERENCED ON THIS PLAN. SEE UTILITY LAYOUT PLANS FOR ALL UTILITIES.

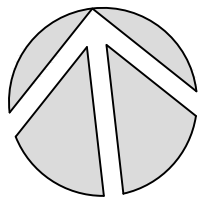

NORTH

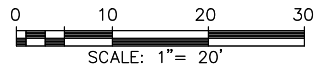

REV. NO.	DATE	DESCRIPTION	BY

**MIG** MOORE IACOFANO GOLTSMAN, INC.  
317 LEXINGTON AVENUE, SUITE 2  
SAN ANTONIO, TEXAS, CA 78215  
TEL 210-600-9990  
www.migcom.com



SAN ANTONIO | AUSTIN | HOUSTON | FORT WORTH | DALLAS  
3800 HWY 190P-418 | SAN ANTONIO, TX 78213 | 210.375.9999  
TEXAS ENGINEERING FIRM #479 | TEXAS SURVEYING FIRM #10028990



CITY OF SAN ANTONIO  
**PUBLIC WORKS DEPARTMENT**

DOLOROSA  
**LANDSCAPE SITE PLAN**

STA 43+00 TO STA 45+00

SHEET 11 OF 16

DESIGN	CHECKED	DRAWN	PROJECT NO.	SUBMITTAL	SHEET NO.
RD/AM	RD/AM	TM/RD	23-03763	70%	326

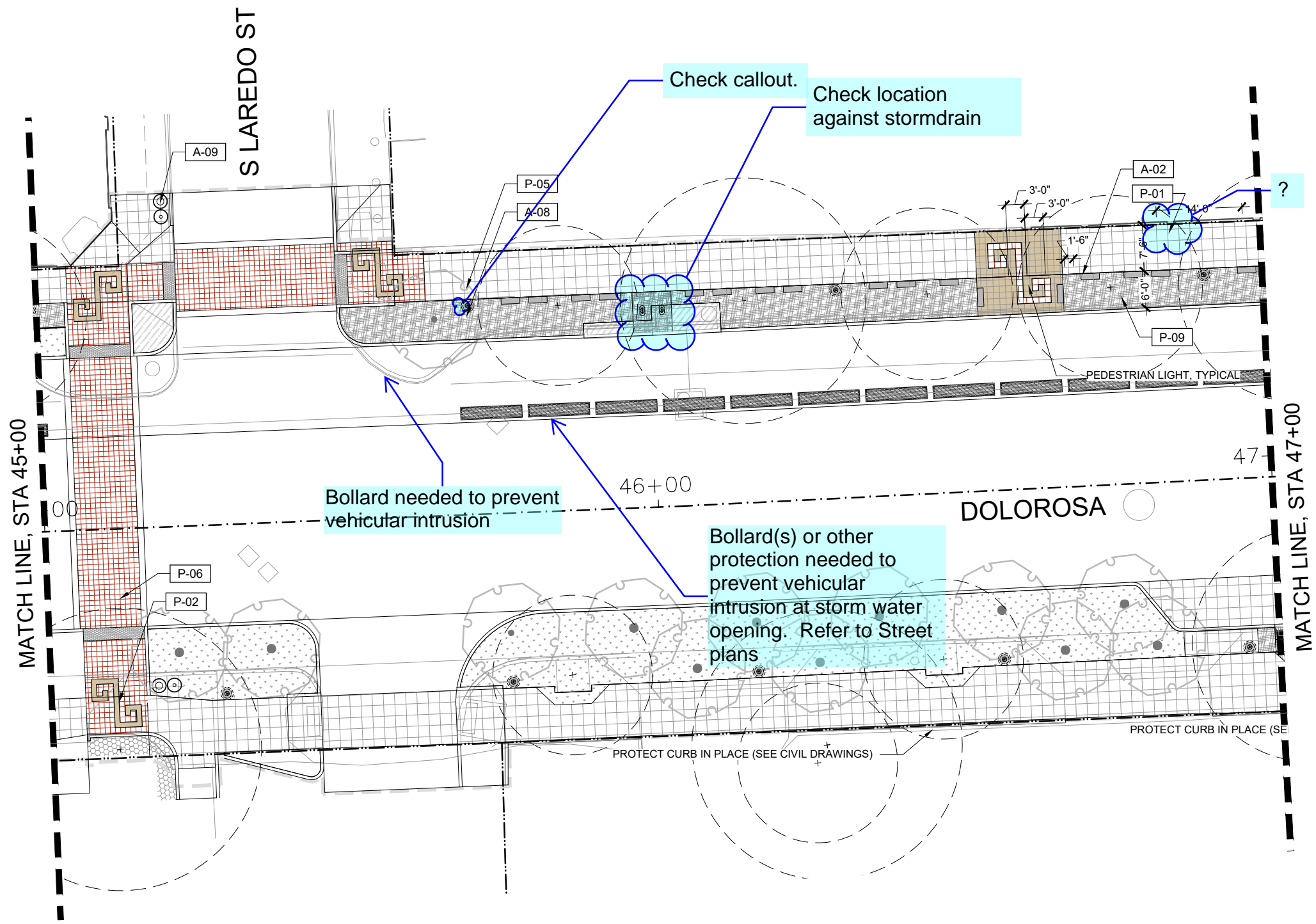

**LEGEND**

P-01	CONC. ACCENT PLAZA W/ GRECA	CONCRETE PAVING CYCLE TRACK (SEE CIVIL)	VIA BUS SHELTER	A-05	BOLLARD, 4" DIAMETER	NEW TREE (SEE PLANTING PLAN)	CENTER STATION LINE
P-02	PORPHYRY PAVING (WALKWAY)	EXISTING LANDSCAPE TO REMAIN	A-01	CHAIR (BACKED AND BACKLESS)	A-06	EXISTING TREE TO REMAIN	PROPERTY LINE / RIGHT OF WAY
P-05	CONCRETE PAVING (SIDEWALK)	EXISTING PAVING TO REMAIN	A-02	BENCH (LIME-STONE BLOCK)	A-08	STRUCTURAL SOIL (SEE PLANTING)	LIMIT OF WORK
P-06	PORPHYRY PAVING (ROADWAY)	UNIT PAVERS TYPE 2 (MARKET SQUARE)		PEDESTRIAN LIGHT (SEE ILLUMINATION PLAN)	A-09	REFER SAN SABA AND SANTA ROSA DRAWINGS	MATCH LINE
P-09	CRUSHED STONE MULCH	PLANTING AREA (SEE PLANTING)			A-10		

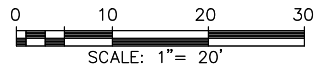
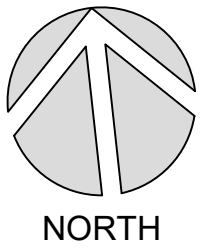

REV. NO.	DATE	DESCRIPTION	BY

**MOORE IACOFANO GOLTSMAN, INC.**  
 317 LEXINGTON AVENUE, SUITE 2  
 SAN ANTONIO, TEXAS, CA 78215  
 TEL 210-600-9990  
 www.migcom.com



SAN ANTONIO | AUSTIN | HOUSTON | FORT WORTH | DALLAS  
 3800 HWY 190P-419 | SAN ANTONIO, TX 78213 | 210.375.9999  
 TEXAS ENGINEERING FIRM #479 | TEXAS SURVEYING FIRM #10028990



CITY OF SAN ANTONIO  
**PUBLIC WORKS DEPARTMENT**  
 DOLOROSA

**LANDSCAPE SITE PLAN**

STA 45+00 TO STA 47+00

SHEET 12 OF 16

DESIGN	CHECKED	DRAWN	PROJECT NO.	SUBMITTAL	SHEET NO.
RD/AM	RD/AM	TM/RD	23-03763	70%	327

NOTE: SEE SCHEDULE SHEET XXX FOR PAVING AND AMENITIES INFORMATION; FOR CLARITY, ALL UTILITIES ARE NOT REFERENCED ON THIS PLAN. SEE UTILITY LAYOUT PLANS FOR ALL UTILITIES.

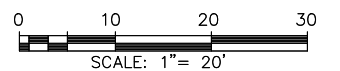
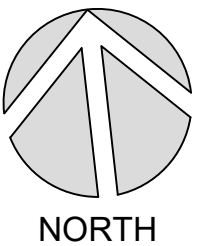
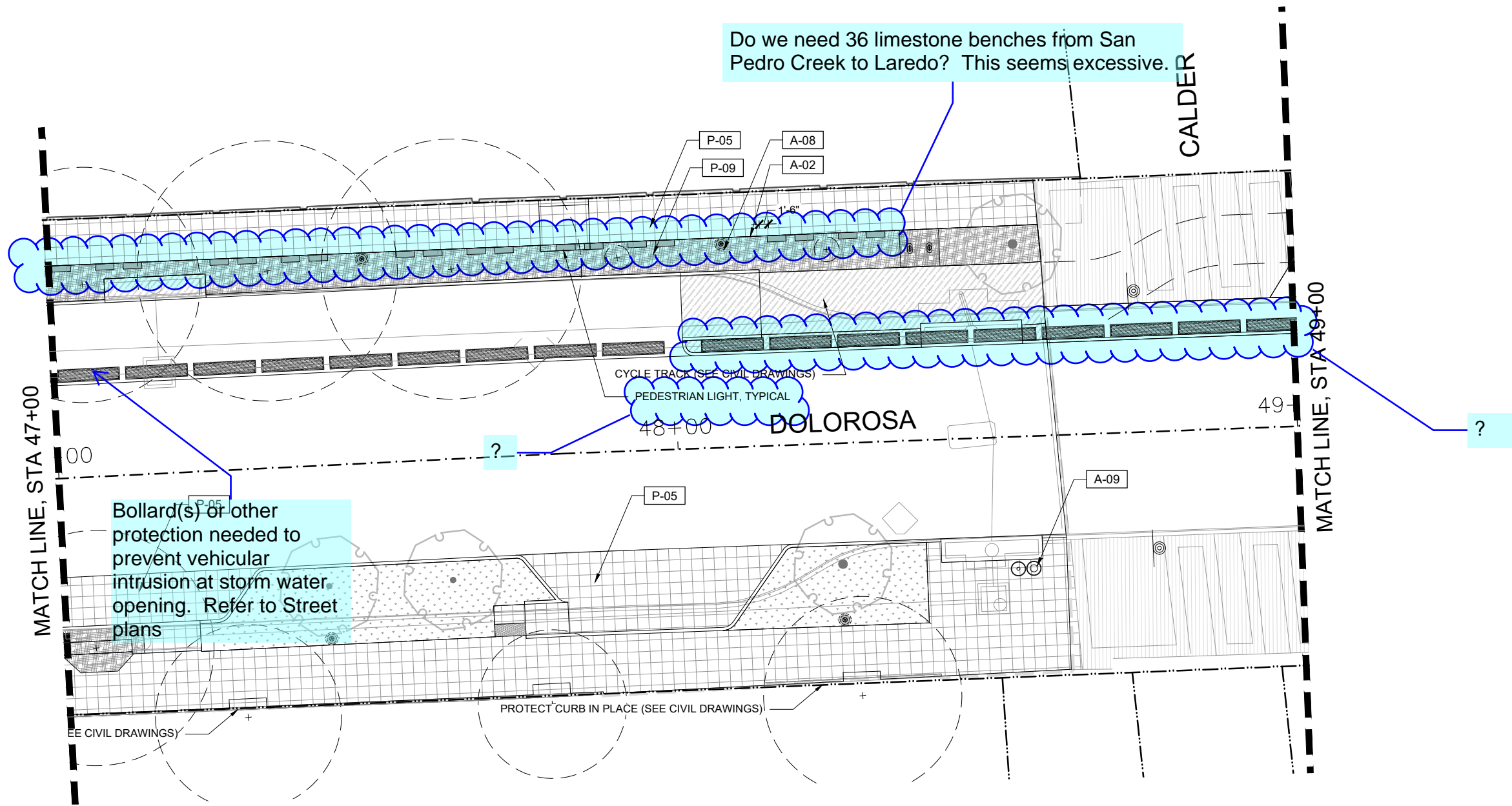

REV. NO.	DATE	DESCRIPTION	BY

**MOORE IACOFANO GOLTSMAN, INC.**  
 317 LEXINGTON AVENUE, SUITE 2    TEL 210-600-9990  
 SAN ANTONIO, TEXAS, CA 78215    www.migcom.com



SAN ANTONIO | AUSTIN | HOUSTON | FORT WORTH | DALLAS  
 3800 HWY 190P-419 | SAN ANTONIO, TX 78213 | 210.375.9999  
 TEXAS ENGINEERING FIRM #479 | TEXAS SURVEYING FIRM #10028990



CITY OF SAN ANTONIO  
**PUBLIC WORKS DEPARTMENT**  
 DOLOROSA  
**LANDSCAPE SITE PLAN**

STA 47+00 TO STA 49+00

SHEET 13 OF 16

**LEGEND**

P-01		CONC. ACCENT PLAZA W/ GRECA		CONCRETE PAVING CYCLE TRACK (SEE CIVIL)		VIA BUS SHELTER	A-05		BOLLARD, 4" DIAMETER		NEW TREE (SEE PLANTING PLAN)	---	CENTER STATION LINE	
P-02		PORPHYRY PAVING (WALKWAY)		EXISTING LANDSCAPE TO REMAIN	A-01		CHAIR (BACKED AND BACKLESS)	A-06		REMOVABLE BOLLARDS		---	PROPERTY LINE / RIGHT OF WAY	
P-05		CONCRETE PAVING (SIDEWALK)		EXISTING PAVING TO REMAIN	A-02		BENCH (LIME-STONE BLOCK)	A-08		BICYCLE RACK	---	STRUCTURAL SOIL (SEE PLANTING)	---	LIMIT OF WORK
P-06		PORPHYRY PAVING (ROADWAY)		UNIT PAVERS TYPE 2 (MARKET SQUARE)		PEDESTRIAN LIGHT (SEE ILLUMINATION PLAN)	A-09		TRASH / RECYCLING		REFER SAN SABA AND SANTA ROSA DRAWINGS	---	MATCH LINE	
P-09		CRUSHED STONE MULCH		PLANTING AREA (SEE PLANTING)	A-10		REMOVABLE PLANTERS							

NOTE: SEE SCHEDULE SHEET XXX FOR PAVING AND AMENITIES INFORMATION; FOR CLARITY, ALL UTILITIES ARE NOT REFERENCED ON THIS PLAN. SEE UTILITY LAYOUT PLANS FOR ALL UTILITIES.

DESIGN	CHECKED	DRAWN	PROJECT NO.	SUBMITTAL	SHEET NO.
RD/AM	RD/AM	TM/RD	23-03763	70%	328

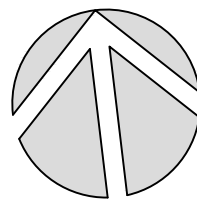
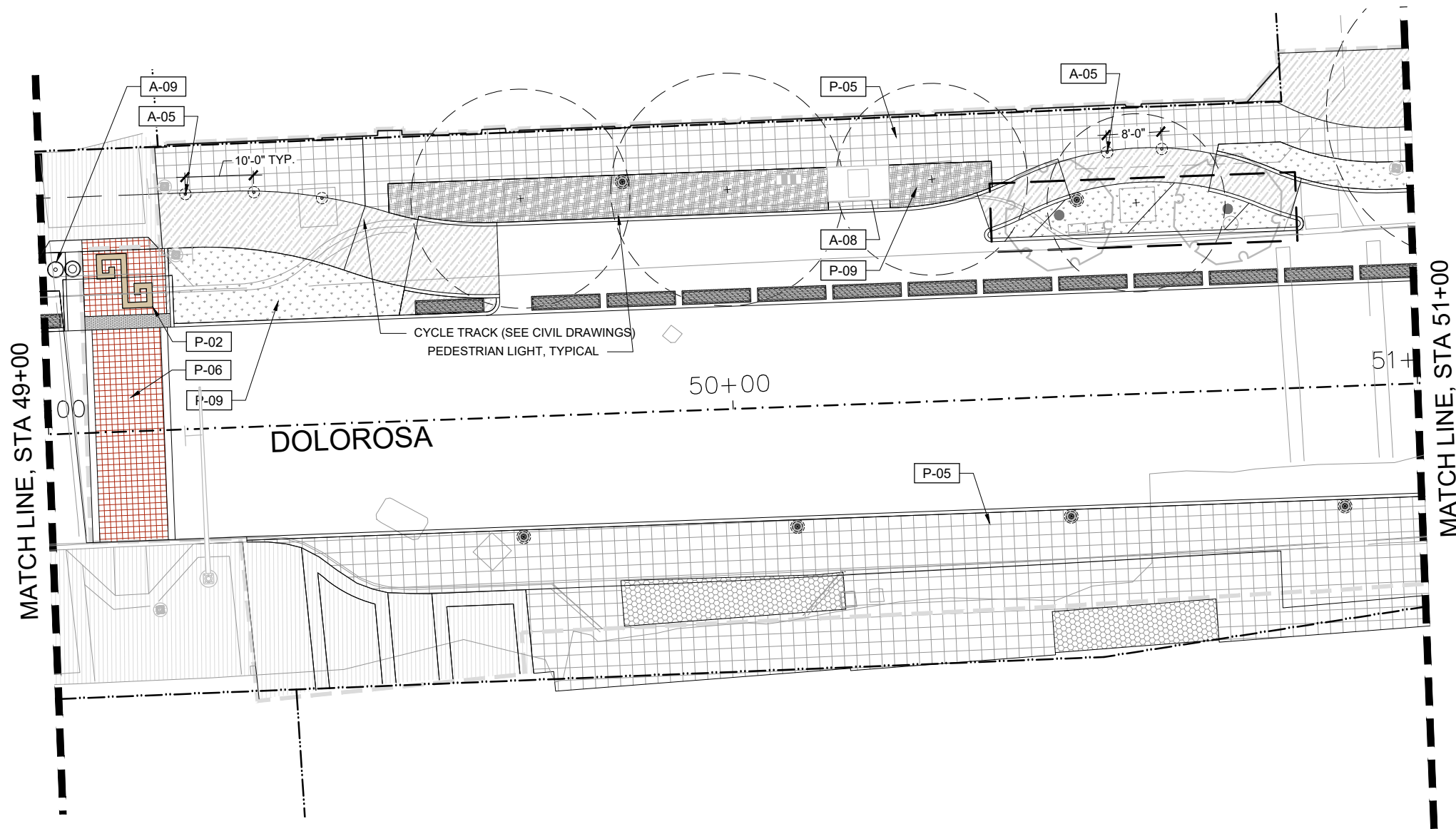

NORTH

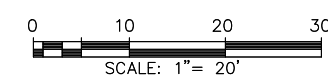

REV. NO.	DATE	DESCRIPTION	BY

**MOORE IACOFANO GOLTSMAN, INC.**  
317 LEXINGTON AVENUE, SUITE 2  
 SAN ANTONIO, TEXAS, CA 78215  
 TEL 210-600-9990  
 www.migcom.com



SAN ANTONIO | AUSTIN | HOUSTON | FORT WORTH | DALLAS  
 3800 HWY 190P-419 | SAN ANTONIO, TX 78213 | 210.375.9999  
 TEXAS ENGINEERING FIRM #479 | TEXAS SURVEYING FIRM #10028990



CITY OF SAN ANTONIO  
**PUBLIC WORKS DEPARTMENT**

DOLOROSA  
**LANDSCAPE SITE PLAN**

STA 49+00 TO STA 51+00

SHEET 14 OF 16

**LEGEND**

P-01		CONC. ACCENT PLAZA W/ GRECA		CONCRETE PAVING CYCLE TRACK (SEE CIVIL)		VIA BUS SHELTER	A-05		BOLLARD, 4" DIAMETER		NEW TREE (SEE PLANTING PLAN)	- - - -	CENTER STATION LINE	
P-02		PORPHYRY PAVING (WALKWAY)		EXISTING LANDSCAPE TO REMAIN	A-01		CHAIR (BACKED AND BACKLESS)	A-06		REMOVABLE BOLLARDS		EXISTING TREE TO REMAIN	- - - -	PROPERTY LINE / RIGHT OF WAY
P-05		CONCRETE PAVING (SIDEWALK)		EXISTING PAVING TO REMAIN	A-02		BENCH (LIME-STONE BLOCK)	A-08		BICYCLE RACK	- - - -	STRUCTURAL SOIL (SEE PLANTING)	- - - -	LIMIT OF WORK
P-06		PORPHYRY PAVING (ROADWAY)		UNIT PAVERS TYPE 2 (MARKET SQUARE)			PEDESTRIAN LIGHT (SEE ILLUMINATION PLAN)	A-09		TRASH / RECYCLING		REFER SAN SABA AND SANTA ROSA DRAWINGS	- - - -	MATCH LINE
P-09		CRUSHED STONE MULCH		PLANTING AREA (SEE PLANTING)	A-10		REMOVABLE PLANTERS							

NOTE: SEE SCHEDULE SHEET XXX FOR PAVING AND AMENITIES INFORMATION; FOR CLARITY, ALL UTILITIES ARE NOT REFERENCED ON THIS PLAN. SEE UTILITY LAYOUT PLANS FOR ALL UTILITIES.

DESIGN	CHECKED	DRAWN	PROJECT NO.	SUBMITTAL	SHEET NO.
RD/AM	RD/AM	TM/RD	23-03763	70%	329

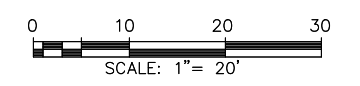
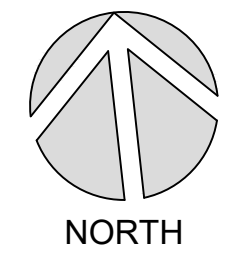
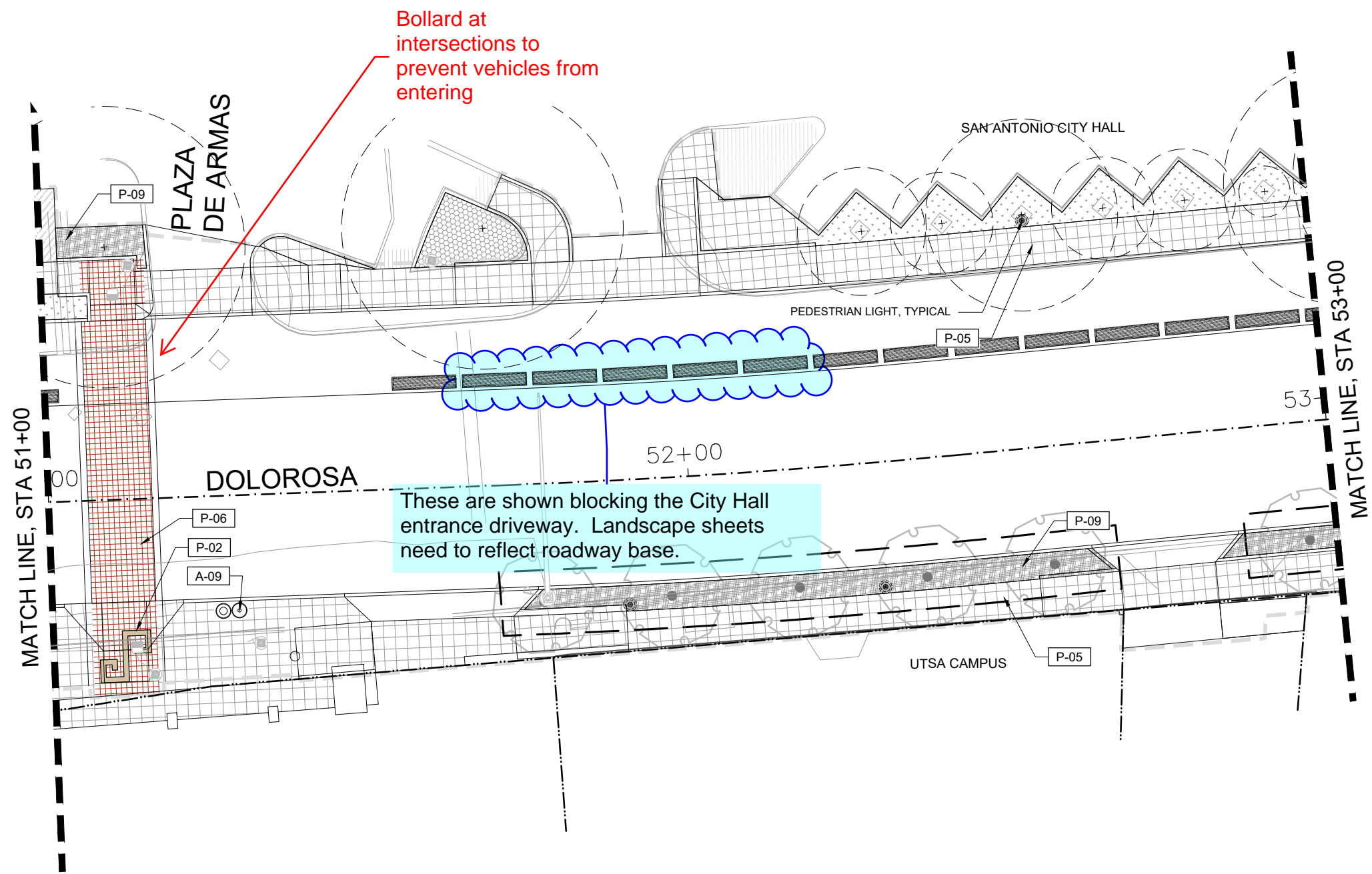

REV. NO.	DATE	DESCRIPTION	BY

**MOORE IACOFANO GOLTSMAN, INC.**  
 317 LEXINGTON AVENUE, SUITE 2  
 SAN ANTONIO, TEXAS, CA 78215  
 TEL 210-600-9990  
 www.migcom.com



SAN ANTONIO | AUSTIN | HOUSTON | FORT WORTH | DALLAS  
 3800 HWY 190P-419 | SAN ANTONIO, TX 78213 | 210.375.9999  
 TEXAS ENGINEERING FIRM #479 | TEXAS SURVEYING FIRM #10028990



CITY OF SAN ANTONIO  
**PUBLIC WORKS DEPARTMENT**

DOLOROSA  
**LANDSCAPE SITE PLAN**

STA 51+00 TO STA 53+00  
 SHEET 15 OF 16

**LEGEND**

P-01	CONC. ACCENT PLAZA W/ GRECA	CONCRETE PAVING CYCLE TRACK (SEE CIVIL)	VIA BUS SHELTER	A-05	BOLLARD, 4" DIAMETER	NEW TREE (SEE PLANTING PLAN)	- - - -	CENTER STATION LINE	
P-02	PORPHYRY PAVING (WALKWAY)	EXISTING LANDSCAPE TO REMAIN	A-01	CHAIR (BACKED AND BACKLESS)	A-06	REMOVABLE BOLLARDS	EXISTING TREE TO REMAIN	- - - -	PROPERTY LINE / RIGHT OF WAY
P-05	CONCRETE PAVING (SIDEWALK)	EXISTING PAVING TO REMAIN	A-02	BENCH (LIME-STONE BLOCK)	A-08	BICYCLE RACK	- - - -	STRUCTURAL SOIL (SEE PLANTING)	
P-06	PORPHYRY PAVING (ROADWAY)	UNIT PAVERS TYPE 2 (MARKET SQUARE)	PEDESTRIAN LIGHT (SEE ILLUMINATION PLAN)	A-09	TRASH / RECYCLING	REFER SAN SABA AND SANTA ROSA DRAWINGS	- - - -	LIMIT OF WORK	
P-09	CRUSHED STONE MULCH	PLANTING AREA (SEE PLANTING)	A-10	REMOVABLE PLANTERS			MATCH LINE		

NOTE: SEE SCHEDULE SHEET XXX FOR PAVING AND AMENITIES INFORMATION; FOR CLARITY, ALL UTILITIES ARE NOT REFERENCED ON THIS PLAN. SEE UTILITY LAYOUT PLANS FOR ALL UTILITIES.

DESIGN	CHECKED	DRAWN	PROJECT NO.	SUBMITTAL	SHEET NO.
RD/AM	RD/AM	TM/RD	23-03763	70%	330



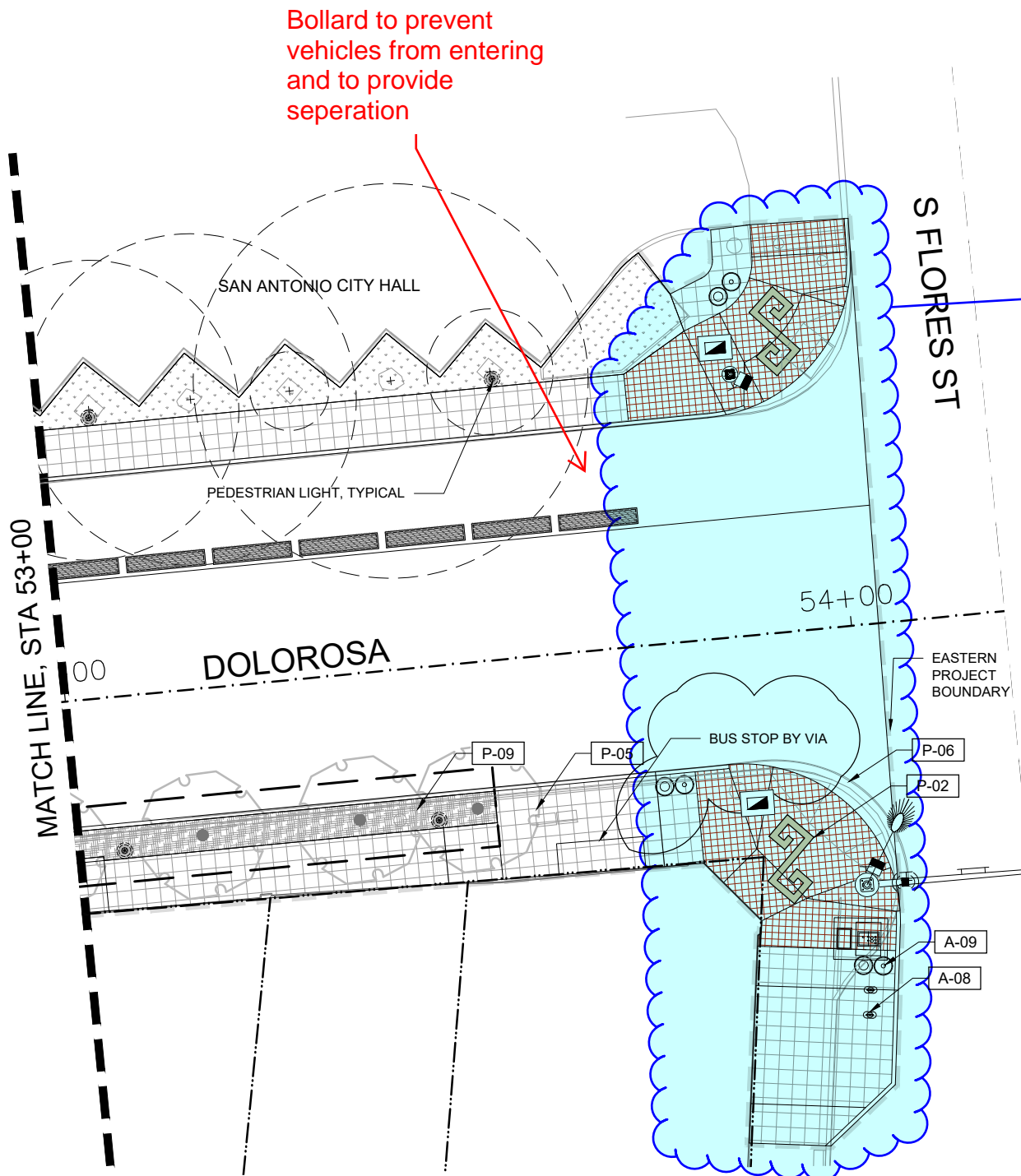

Remove Zona elements from Flores intersection. Flores Street project will impact this and likely necessitate reconstruction.

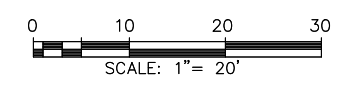
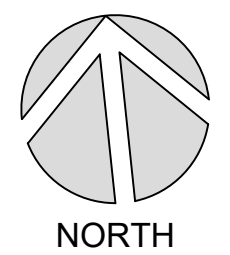

REV. NO.	DATE	DESCRIPTION	BY
<b>MOORE IACOFANO GOLTSMAN, INC.</b> <small>317 LEXINGTON AVENUE, SUITE 2  SAN ANTONIO, TEXAS, CA 78215  TEL 210-600-9990  www.migcom.com</small>			



DOLOROSA  
**LANDSCAPE SITE PLAN**

STA 53+00 TO STA 55+00

SHEET 16 OF 16

**LEGEND**

P-01		CONC. ACCENT PLAZA W/ GRECA		CONCRETE PAVING CYCLE TRACK (SEE CIVIL)		VIA BUS SHELTER	A-05		BOLLARD, 4" DIAMETER		NEW TREE (SEE PLANTING PLAN)	---	CENTER STATION LINE	
P-02		PORPHYRY PAVING (WALKWAY)		EXISTING LANDSCAPE TO REMAIN	A-01		CHAIR (BACKED AND BACKLESS)	A-06		REMOVABLE BOLLARDS		---	PROPERTY LINE / RIGHT OF WAY	
P-05		CONCRETE PAVING (SIDEWALK)		EXISTING PAVING TO REMAIN	A-02		BENCH (LIME-STONE BLOCK)	A-08		BICYCLE RACK	---	STRUCTURAL SOIL (SEE PLANTING)	---	LIMIT OF WORK
P-06		PORPHYRY PAVING (ROADWAY)		UNIT PAVERS TYPE 2 (MARKET SQUARE)			PEDESTRIAN LIGHT (SEE ILLUMINATION PLAN)	A-09		TRASH / RECYCLING		---	MATCH LINE	
P-09		CRUSHED STONE MULCH		PLANTING AREA (SEE PLANTING)				A-10		REMOVABLE PLANTERS				

NOTE: SEE SCHEDULE SHEET XXX FOR PAVING AND AMENITIES INFORMATION; FOR CLARITY, ALL UTILITIES ARE NOT REFERENCED ON THIS PLAN. SEE UTILITY LAYOUT PLANS FOR ALL UTILITIES.

DESIGN	CHECKED	DRAWN	PROJECT NO.	SUBMITTAL	SHEET NO.
RD/AM	RD/AM	TM/RD	23-03763	70%	331

**NOTES:**

1. PROVIDE 1/2" PRE-FORMED EXPANSION JOINT WITH SEALER WHERE CONCRETE PAVING MEETS VERTICAL SURFACE, TYP. AND WHERE SHOWN ON THE DRAWINGS.
2. SEE PAVING SCHEDULE AND DECORATIVE CONCRETE PAVING SPEC 03-3500 FOR CONCRETE FINISH INFO. SEE STONE PAVING SPEC 32 1440 FOR PORPHYRY STONE.

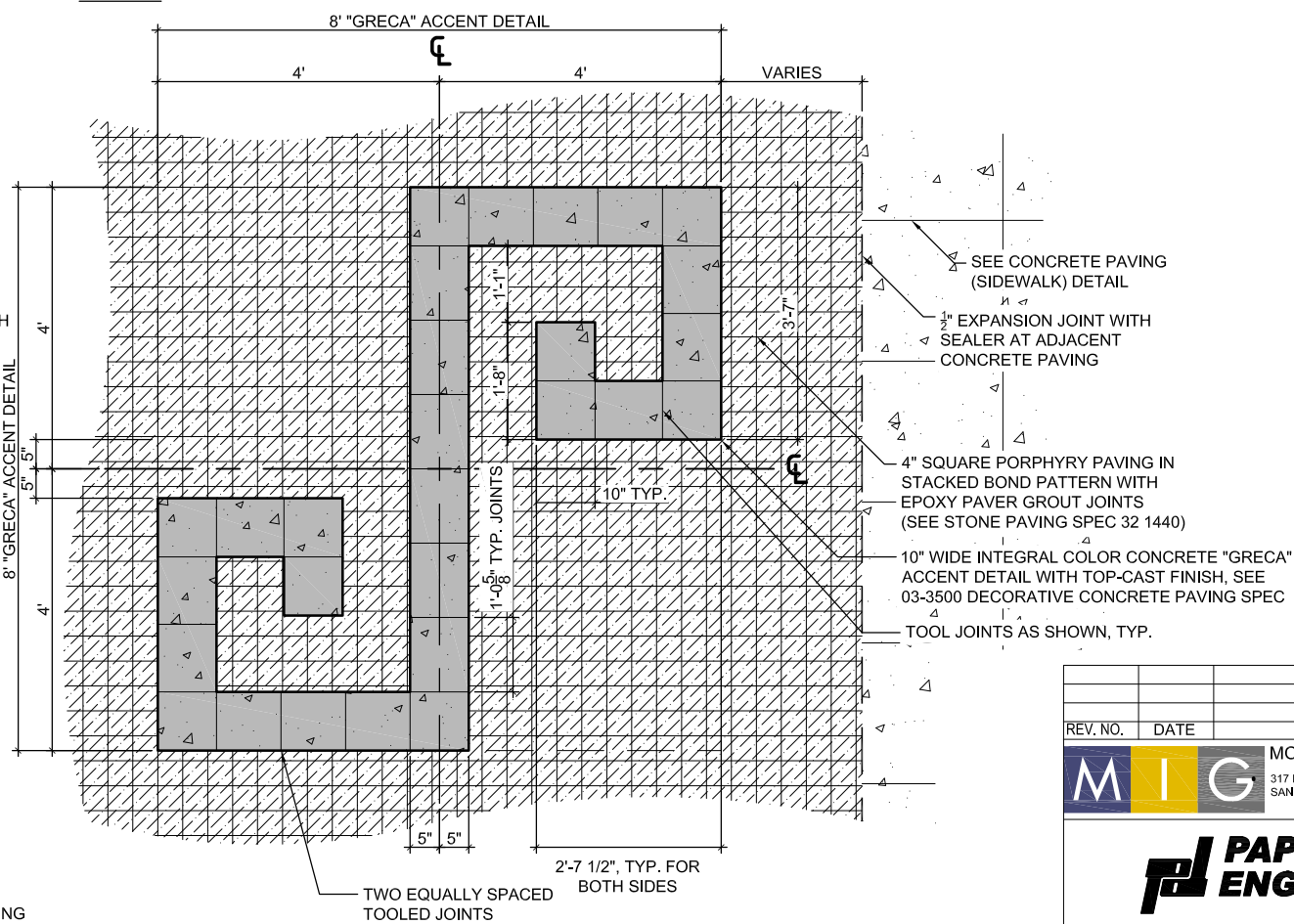
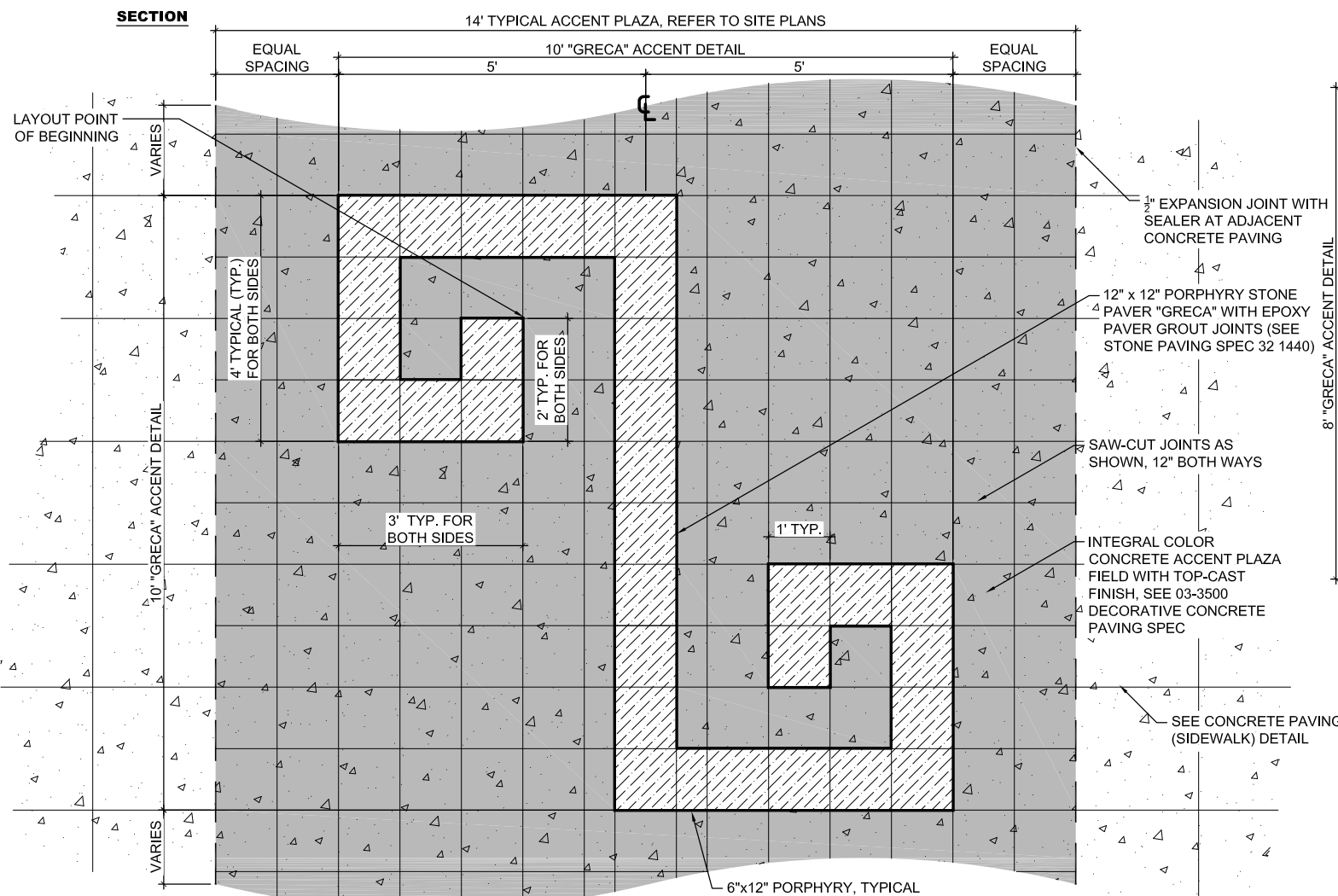
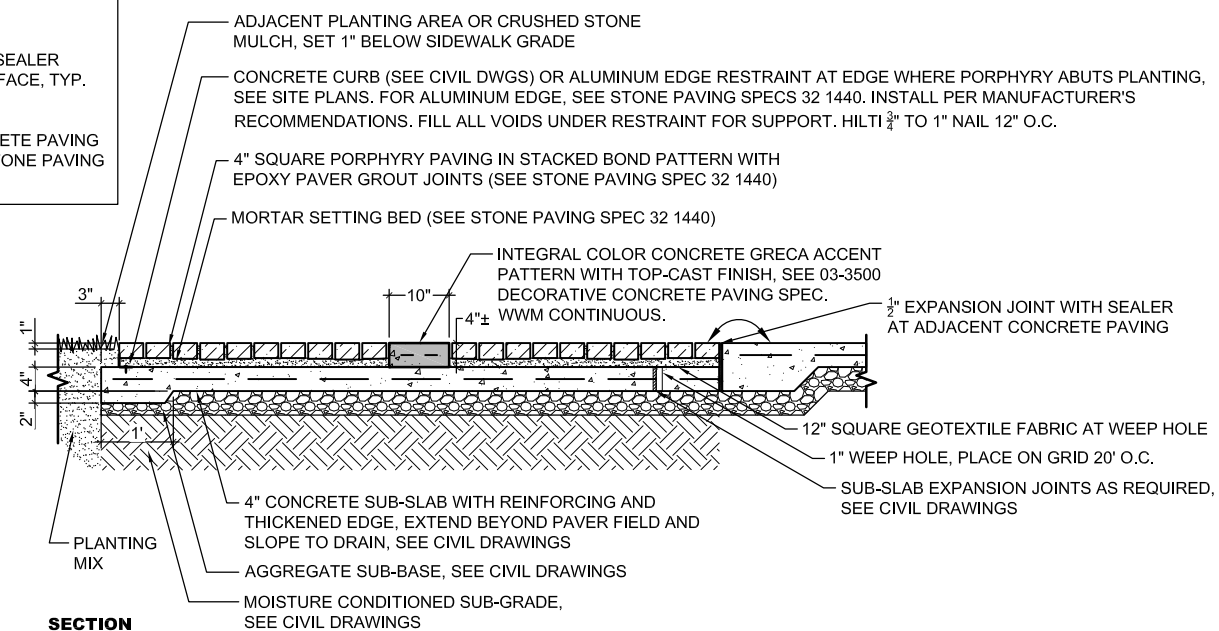
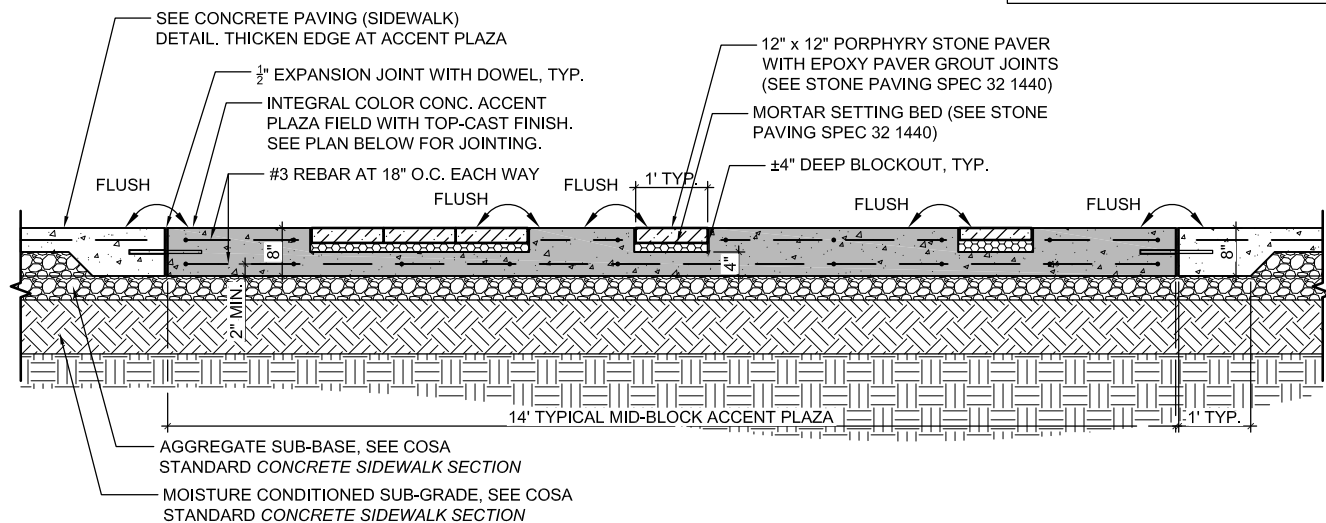

1 CONCRETE ACCENT PLAZA WITH PORPHYRY GRECA DETAIL (MID-BLOCK)  
3/8" = 1'-0"

P-01

2 PORPHYRY PAVING (WALKWAY) WITH CONCRETE GRECA DETAIL  
3/8" = 1'-0"

P-02

REV. NO.	DATE	DESCRIPTION	BY
 <b>MOORE IACOFANO GOLTSMAN, INC.</b> 317 LEXINGTON AVENUE, SUITE 2 SAN ANTONIO, TEXAS, CA 78215 TEL 210-600-9990 www.mlgcom.com			

**PAPE-DAWSON ENGINEERS**

SAN ANTONIO | AUSTIN | HOUSTON | FORT WORTH | DALLAS  
 2000 NW LOOP 410 | SAN ANTONIO, TX 78219 | 210.875.9900  
 TEXAS ENGINEERING FIRM #170 | TEXAS SURVEYING FIRM #10028900



CITY OF SAN ANTONIO  
**PUBLIC WORKS DEPARTMENT**

DOLOROSA

LANDSCAPE SITE DETAILS

SHEET 1 OF 3

DESIGN	CHECKED	DRAWN	PROJECT NO.	SUBMITTAL	SHEET NO.
RD/AM	RD/AM	TM/RD	23-03763	70%	332

**NOTES:**

1. SEE COSA STANDARD CONCRETE SIDEWALK SECTION FOR REINFORCING AND CONCRETE INFO.
2. PROVIDE 1/2" PRE-FORMED EXPANSION JOINT WITH SEALER WHERE CONCRETE PAVING MEETS VERTICAL SURFACE, TYP. AND WHERE SHOWN ON THE DRAWINGS.
3. SEE PAVING SCHEDULE AND DECORATIVE CONCRETE PAVING SPEC 03-3500.
4. 24" x 24" SQUARE SAW-CUT JOINT PATTERN

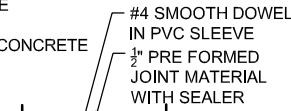
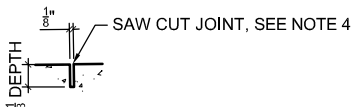

**EXPANSION JOINT (EVERY 20' O.C. OR WHERE SHOWN) (NTS)**

**CONTROL JOINT (NTS)**

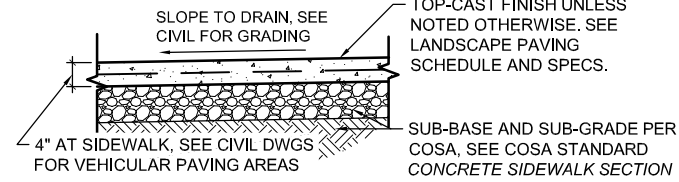

**SECTION**

**1** CONCRETE PAVING (SIDEWALK, ON STREET PARKING)  
3/8" = 1'-0"

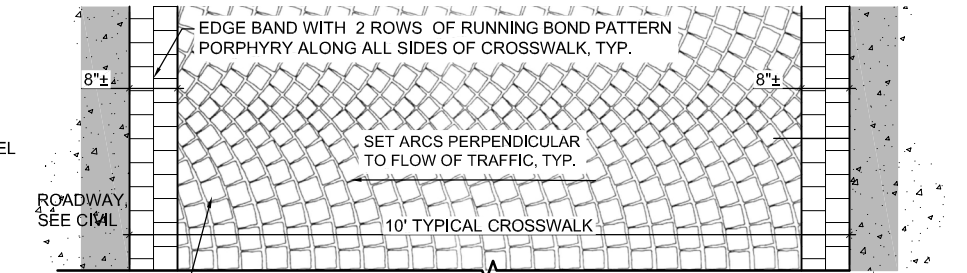

**PLAN**

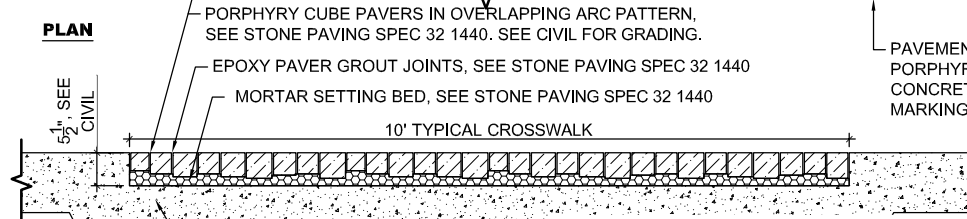

**SECTION**

**2** PORPHYRY PAVING (CROSSWALK AND ROADWAY)  
3/8" = 1'-0"

**NOTE:**  
1. CHORD LENGTH AND QUANTITY OF OVERLAPPING ARCS VARIES BASED ON ROADWAY WIDTH. LANDSCAPE ARCHITECT TO CONFIRM DIMENSIONS PRIOR TO INSTALLATION.

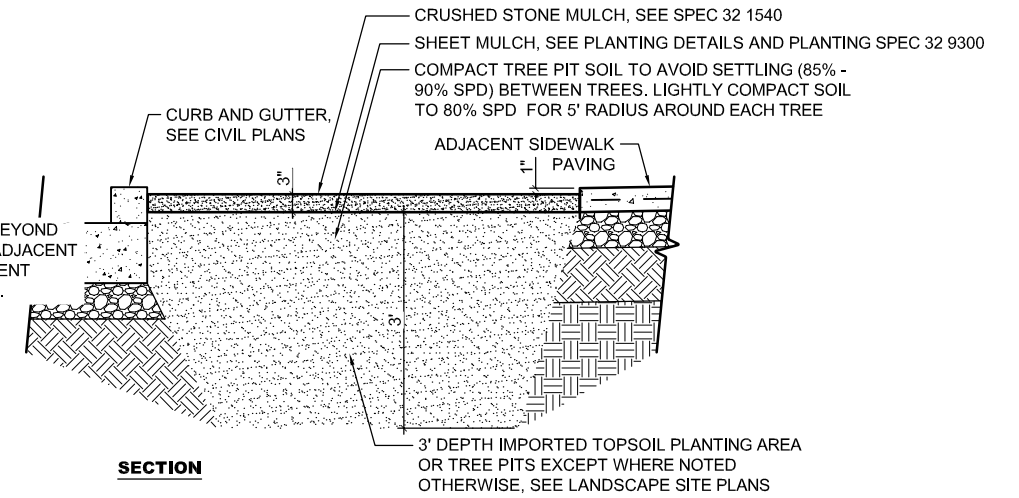

**SECTION**

**3** CRUSHED STONE MULCH  
3/8" = 1'-0"

Add detail for Unit Pavers at Market Square

Need detail of the planters

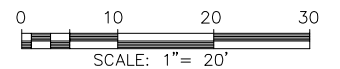

REV. NO.	DATE	DESCRIPTION	BY

**MIG** MOORE IACOFANO GOLTSMAN, INC.  
317 LEXINGTON AVENUE, SUITE 2  
SAN ANTONIO, TEXAS, CA 78215  
TEL 210-600-9990  
www.migcom.com

**Pape-Dawson Engineers**  
SAN ANTONIO | AUSTIN | HOUSTON | FORT WORTH | DALLAS  
2000 NW LOOP 410 | SAN ANTONIO, TX 78219 | 210.876.9000  
TEXAS ENGINEERING FIRM #170 | TEXAS SURVEYING FIRM #10028600

CITY OF SAN ANTONIO  
PUBLIC WORKS DEPARTMENT

DOLOROSA

LANDSCAPE SITE DETAILS

SHEET 2 OF 3

DESIGN	CHECKED	DRAWN	PROJECT NO.	SUBMITTAL	SHEET NO.
RD/AM	RD/AM	TM/RD	23-03763	70%	333

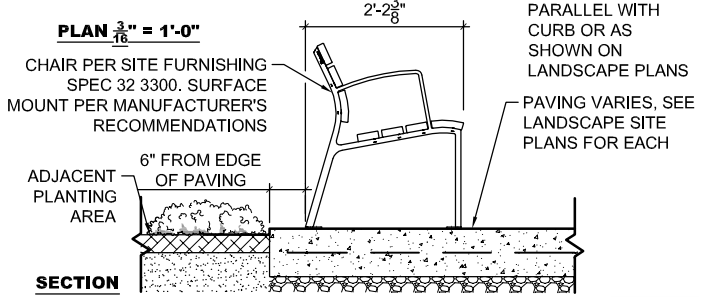
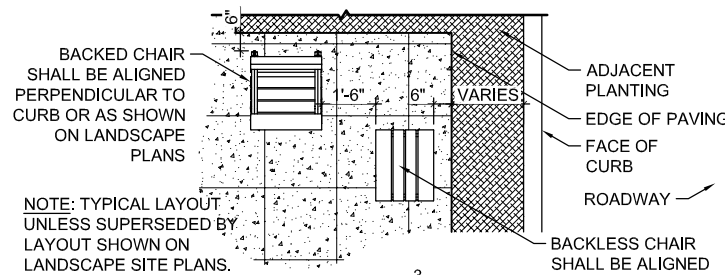

1 CHAIR (BACKED AND BACKLESS) A-01  
 $\frac{3}{8}'' = 1'-0''$

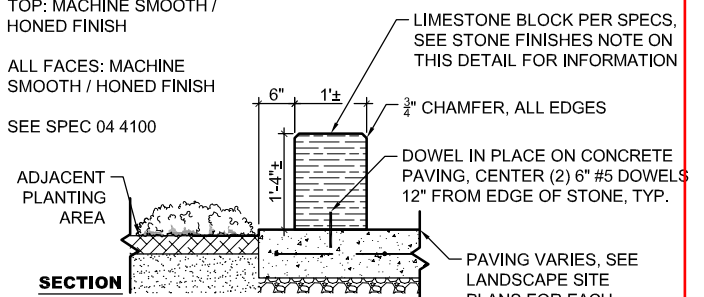
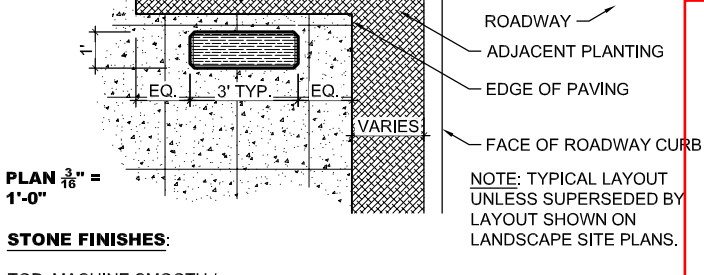

2 BENCH (LIMESTONE BLOCK) A-02  
 $\frac{3}{8}'' = 1'-0''$

- NOTES:
- SEE LANDSCAPE SITE PLANS FOR BOLLARD LOCATIONS.
  - SEE MATERIALS SCHEDULE AND SITE FURNISHING SPEC 32 3300 FOR PRODUCT INFORMATION.
  - INSTALL PER MANUFACTURER'S INSTRUCTIONS (SEE SPECS).

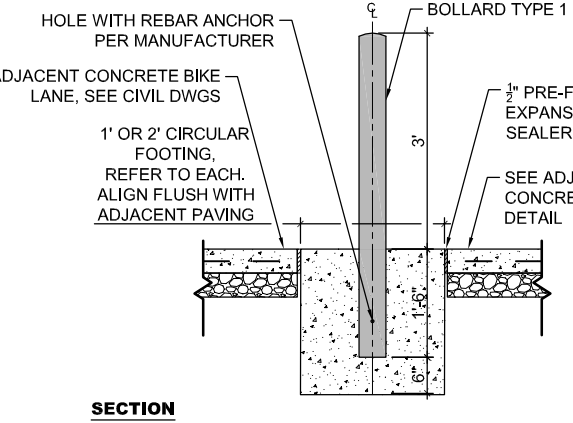

3 BOLLARD TYPE 1 A-05  
 $\frac{3}{8}'' = 1'-0''$

- NOTES:
- SEE LANDSCAPE SITE PLANS FOR BOLLARD LOCATIONS.
  - SEE MATERIALS SCHEDULE AND SITE FURNISHING SPEC 32 3300 FOR PRODUCT INFORMATION.
  - INSTALL PER MANUFACTURER'S INSTRUCTIONS (SEE SPECS).

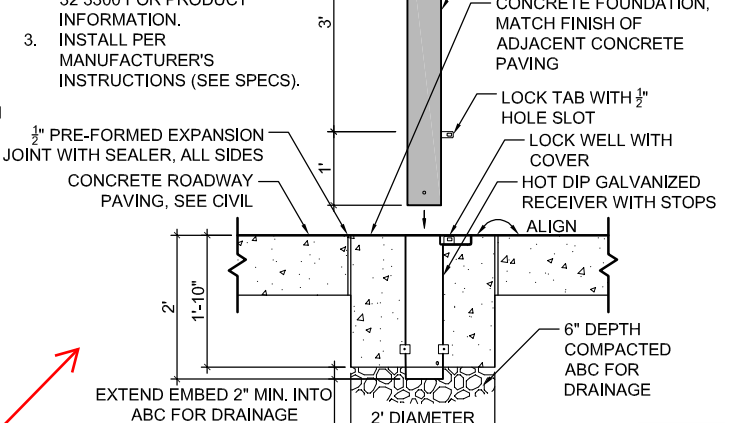

4 BOLLARD TYPE 2 (REMOVABLE) A-06  
 $\frac{3}{8}'' = 1'-0''$

Show minimum allowable, confirm with dimension on plan layouts.

When and where is each one used?

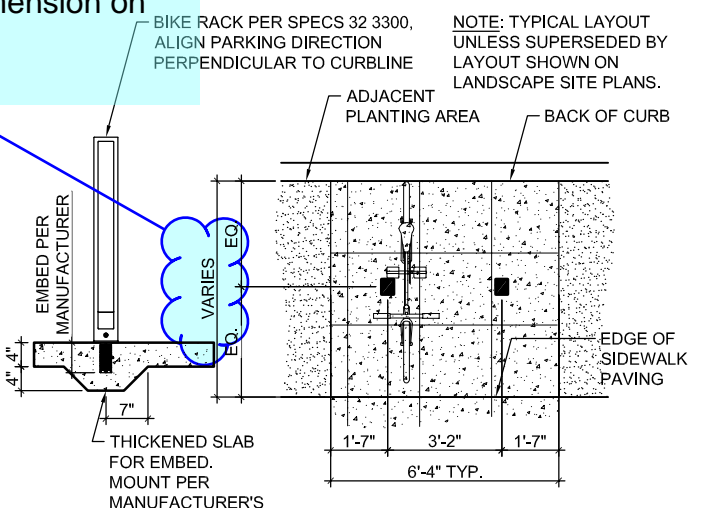

5 BIKE RACK A-08  
 $\frac{3}{8}'' = 1'-0''$

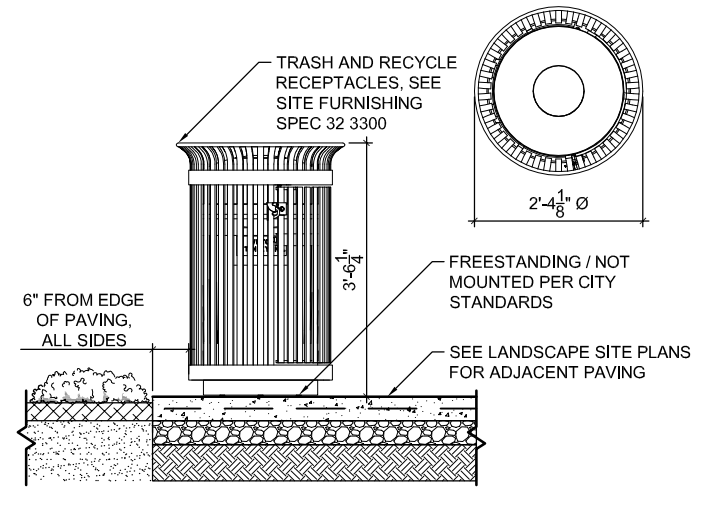

6 TRASH AND RECYCLE BIN A-09  
 $\frac{3}{8}'' = 1'-0''$

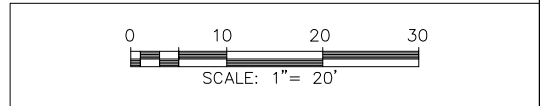

REV. NO.	DATE	DESCRIPTION	BY

MOORE IACOFANO GOLTSMAN, INC.  
317 LEXINGTON AVENUE, SUITE 2  
SAN ANTONIO, TEXAS, CA 78215  
TEL 210-600-9990  
www.migcom.com

**PAPE-DAWSON ENGINEERS**

SAN ANTONIO | AUSTIN | HOUSTON | FORT WORTH | DALLAS  
2000 NW LOOP 410 | SAN ANTONIO, TX 78219 | 210.875.9000  
TEXAS ENGINEERING FIRM #170 | TEXAS SURVEYING FIRM #10028600

CITY OF SAN ANTONIO  
PUBLIC WORKS DEPARTMENT

DOLOROSA

LANDSCAPE SITE DETAILS

SHEET 3 OF 3

DESIGN	CHECKED	DRAWN	PROJECT NO.	SUBMITTAL	SHEET NO.
RD/AM	RD/AM	TM/RD	23-03763	70%	334

# LANDSCAPE IRRIGATION LEGEND

SYMBOL	MFG'R	MODEL NO.	DESCRIPTION	REMARKS	DETAIL
	(OR EQUAL)				
	SUPERIOR CONTROLS	3200	MASTER VALVE	SIZE PER PLAN, NORMALLY CLOSED MASTER CONTROL VALVE	5/ XXX
	MATCO	503 SERIES	MAINLINE ISOLATION GATE VALVES (3-INCH AND SMALLER)	MAIN LINE SIZE. REFER TO PLANS FOR APPROXIMATE LOCATIONS	4-5/ XXX 1/ XXX
	HUNTER	ICV-###G	REMOTE CONTROL VALVE	SIZE PER PLAN.	4-5/ XXX 5/ XXX
	HUNTER	SEE REMARKS	DRIP REMOTE CONTROL VALVE ASSEMBLY	SIZE AS PER PLAN. INSTALL WITH IN-LINE PRESSURE REGULATOR, SET AT 40 PSI AND PLASTIC FILTER (150 MESH SIZE). INSTALL MODEL 1CZ-101-LF FOR ZONES WITH FLOWS BETWEEN 0.5 AND 15 GPM; INSTALL MODEL ICZ-101 FOR ZONES WITH FLOWS GREATER THAN 15 GPM AND LESS THAN 20 GPM.	4-5/ XXX 5/ XXX 1/ XXX
	RAIN BIRD	44-LRC	BRASS SINGLE-PIECE QUICK COUPLING VALVE	1-INCH SIZE WITH LOCKING COVER. PLACE IN VALVE BOX WITH LOCKING BOLT-DOWN LID. REFER TO SPECS. PROVIDE W/ TWO (2) 2049 LOCKING COVER KEYS, TWO (2) SH-2 HOSE SWIVELS, TWO (2) 44-K BRASS QC KEYS FOR EVERY (3) QUICK COUPLING VALVES INSTALLED.	4-5/ XXX 4/ XXX
	PW PIPE	N/A	PRESSURE MAINLINE PIPE	SIZE AS PER PLAN. SCH. 40 PVC PIPE. INSTALL W/ COPPER TRACE WIRE, TAPED TO MAINLINE AT 10-FOOT INTERVALS, ALONG ALL MAINLINE. NOTE: MAINLINE SHOWN IN PAVED AREAS FOR GRAPHICAL CLARITY ONLY.	1/ XXX
	PW PIPE	N/A	NON-PRESSURE LATERAL PIPE	SIZE PER PLAN. CLASS 200 PVC PIPE.	
	PW PIPE	N/A	IRRIGATION PIPE / CONTROL WIRE SLEEVE	SCH. 40 PVC. QUANTITY AS REQUIRED. REFER TO PIPE/WIRE SLEEVING CHART FOR SIZE (SHEET -). PROVIDE AN EXTRA 2" SLEEVE NEXT TO ALL MAINLINE SLEEVE LOCATIONS TO ALLOW FOR TWO-WIRE DECODER WIRE FROM CONTROLLER (NOT SHOWN ON PLANS)	2/ XXX

## TREE BUBBLER LEGEND

SYMBOL	MFG'R	MODEL NO.	DESCRIPTION	OP. PSI	REMARKS	DETAIL
	(OR EQUAL)					
	HUNTER	RZWS-36-25 -CV/ PCB-25	TREE ROOT WATERING SYSTEMS IN PLANTING BEDS	30	FLOW: 0.25 EACH. INSTALL TWO (2) ROOT ZONE WATERING TUBES IN ADDITION TO TWO (2) ON-GRADE BUBBLER ON FLEXIBLE TUBING. LOCATIONS AND QUANTITIES ARE APPROXIMATE. ACTUAL LOCATIONS AND QUANTITIES SHALL BE FIELD DETERMINED TO CONFORM WITH FINAL PLANTING PLAN.	6-7/ XXX
	CITY GREEN	ROOTRAIN URBAN	TREE PIT IRRIGATION PLUMBED WITH BUBBLER NOZZLE ON THREAD ADAPTER	30	INSTALL TWO (2) RINGS PER TREE. PLUMB EACH RING WITH (1) HUNTER PCB-50 BUBBLER. USE SINGLE INLET MODEL (RRURB1) DIRECTLY ADJACENT TO ROOTBALL; USE DOUBLE INLET MODEL (RRURB2) AT PERIMETER OF PLANTER WELL. REFER TO DETAIL.	8/ XXX

## SUB-SURFACE IRRIGATION SYSTEM

SYMBOL	MFG'R	MODEL NO.	DESCRIPTION	REMARKS	DETAIL			
	(OR EQUAL)							
	NETAFIM	TLAVRV	AIR/VACUUM RELIEF VALVE	3/4-INCH SIZE, MPT; FIELD LOCATE AT HIGHEST POINT IN EACH HYDROZONE AS SHOWN ON PLAN AND AS PER MFG'R RECOMMENDATIONS.	2/ XXX			
	NETAFIM	TLSOV	MANUAL FLUSH COUPLING AND CAP	LOCATE PER PLAN. ATTACH 3-FEET OF BLANK TUBING AND COIL WITHIN VALVE BOX AS PER DETAIL.	3/ XXX			
	HUNTER	ECO-INDICATOR	YELLOW POP-UP INDICATOR	INSTALL AT APPROXIMATE LOCATIONS SHOWN ON PLAN.	4/ XXX			
	NETAFIM	TLHCVXR5-12##	INLINE EMITTER DRIPLINE W/ CUPRON ROOT INTRUSION PROTECTION, ANTI-SIPHON, PRESSURE COMPENSATING, SELF-FLUSHING EMITTERS W/ HIGH CHECK VALVE. USE NETAFIM 17MM INSERT FITTINGS. .	OPERATING PSI	EMITTER FLOW	MAX ALLOWED HORIZONTAL SPACING	BURIAL DEPTH	5/ XXX 1-3/ XXX
				30	0.56 GPH	12"	3"	

## EXISTING IRRIGATION SYSTEM

SYMBOL	DESCRIPTION	REMARKS	DETAIL
	EXISTING IRRIGATION	CONTRACTOR SHALL ADJUST (E) IRRIGATION HEADS AND PROVIDE ADDITIONAL IRRIGATION HEADS AS REQUIRED TO MAINTAIN AND PROVIDE HEAD-TO-HEAD COVERAGE OF ALL PLANTED AREAS TO REMAIN WITH PROJECT'S LIMIT OF WORK.	N/A

SYMBOL	MFG'R	MODEL NO.	DESCRIPTION	REMARKS	DETAIL
	(OR EQUAL)				
	N/A	N/A	WATER METER (WM)	BY OTHERS, REFER TO CIVIL DWGS. SIZE PER PLAN. VERIFY STATIC WATER PRESSURE IN FIELD PRIOR TO CONSTRUCTION.	PER CIVIL DWGS.
	N/A	N/A	DOUBLE CHECK VALVE ASSEMBLY (DCVA)	INSTALL BELOW GRADE WITHIN VAULT. SIZE PER PLAN.	2/ XXX

## CONTROLLER SCHEDULE

SYMBOL	MFG'R	MODEL NO.	DESCRIPTION	REMARKS	DETAIL
	HUNTER	A2C-75D-M	AUTOMATIC IRRIGATION CONTROLLER 'A'	75-STATION , TWO-WIRE CONTROLLER IN METAL CABINET. MOUNT CONTROLLER WITHIN STRONGBOX PEDESTAL ENCLOSURE MODEL # SB-18SS. PROVIDE WITH HUNTER WIRELESS SOLAR SYNC ASSEMBLY (SENSOR AND RECEIVER). INSTALL RECEIVER ON ONE SIDE OF ENCLOSURE WITH HUNTER WR-GUARD. SOLAR SYNC SHALL BE INSTALLED AT FINAL LOCATION AS DIRECTED BY OWNER AND LANDSCAPE ARCHITECT.	3/ XXX
	HUNTER	WWS-SEN	WIRELESS SOLAR SYNC SENSOR, RECEIVER, AND MOUNT	ONE PER CONTROLLER.	PER MFG'R
	HUNTER	HFS-FCT-100	IMPELLER-TYPE FLOW SENSOR WITH SENSOR RECEPTACLE TEE	1" SIZE. WIRE DIRECTLY TO TWO-WIRE DECODER CABLE USING SENSOR DECODER (ICD-SEN). 2 GALLON PER MINUTE FLOW REQUIRED TO REGISTER FLOW.	5/ XXX 3/ XXX
NOT SHOWN	HUNTER	ID2GRY	TWO-WIRE DECODER CABLE	12 AWG SOLID-CORE TWISTED PAIR, POLYETHYLENE COATED DOUBLE JACKETED (GRAY) CABLE. SPLICES WHEN APPROVED SHALL BE WATERTIGHT ELECTRICAL WIRE CONNECTORS 3M MODEL # DBRY-6	2/ XXX
NOT SHOWN	HUNTER	1CD-100	TWO-WIRE DECODERS	SINGLE-STATION DECODER WITH SURGE SUPPRESSION AND GROUND WIRE.	4/ XXX

## GENERAL LEGEND

SLEEVING: INSTALL IN LOCATIONS AS SHOWN ON PLAN. REFER TO PIPE/WIRE SLEEVING CHART ON THIS SHEET FOR SIZE AND TYPE.

- (#) M = MAINLINE SLEEVE
- (#) L = LATERAL SLEEVE
- (#) W = WIRING CONDUIT

### VALVE CALL OUT

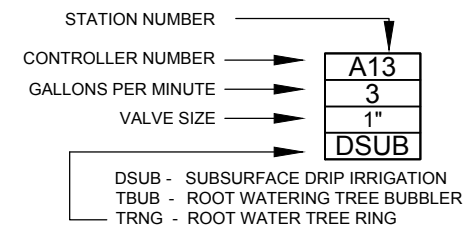

LIMIT OF WORK

## STATEMENT OF IRRIGATION DESIGN STANDARDS CONFORMITY

THESE PLANS IS COMPLETE AND CONFORMS TO THE DESIGN AND INSTALLATION PARAMETERS OF THE IRRIGATION DESIGN AND EQUIPMENT STANDARDS SET OUT IN 35-510(j) AND 35-511(C)(6) OF THE CITY OF SAN ANTONIO UNIFIED DEVELOPMENT CODE.

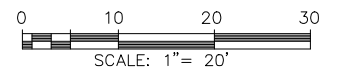

REV. NO.	DATE	DESCRIPTION	BY

MOORE IACOFANO GOLTSMAN, INC.  
317 LEXINGTON AVENUE, SUITE 2  
SAN ANTONIO, TEXAS, CA 78215  
TEL 210-600-9990  
www.migcom.com

**PAPE-DAWSON ENGINEERS**

SAN ANTONIO | AUSTIN | HOUSTON | FORT WORTH | DALLAS  
3000 HWY 198P 410 | SAN ANTONIO, TX 78213 | 210.325.9999  
TEXAS ENGINEERING FIRM #170 | TEXAS SURVEYING FIRM #10099900



CITY OF SAN ANTONIO  
PUBLIC WORKS DEPARTMENT

DOLOROSA

IRRIGATION LEGEND

SHEET 1 OF 1

DESIGN	CHECKED	DRAWN	PROJECT NO.	SUBMITTAL	SHEET NO.
RD/AM	RD/AM	TM/RD	23-03763	70%	335

# GENERAL LANDSCAPE IRRIGATION NOTES

1. THE IRRIGATION SYSTEM DESIGN FOR POINT-OF-CONNECTION (POC) IS BASED ON A MINIMUM EXISTING AVERAGE STATIC PRESSURE OF AT THE MUNICIPAL SERVICE LINE AND A MAXIMUM DEMAND AS NOTED ON THE PLANS. THE CONTRACTOR SHALL PROVIDE A STATIC PRESSURE TEST AT POC FOR APPROVAL BY CITY OF SAN ANTONIO'S REPRESENTATIVE PRIOR TO ORDERING MATERIALS AND PRIOR TO CONSTRUCTION. CONTRACTOR SHALL REPORT ANY DIFFERENCE BETWEEN THE WATER PRESSURE INDICATED ON THE DRAWINGS AND THE ACTUAL PRESSURE READING AT THE IRRIGATION POINT OF CONNECTIONS TO THE CITY OF SAN ANTONIO'S REPRESENTATIVE. IN THE EVENT PRESSURE DIFFERENCES ARE NOT REPORTED PRIOR TO THE START OF CONSTRUCTION, THE CONTRACTOR SHALL ASSUME FULL RESPONSIBILITY FOR ANY REVISIONS NECESSARY.
2. THESE DRAWINGS ARE DIAGRAMMATIC. DRAWINGS DO NOT SHOW ALL OFFSETS AND FITTINGS REQUIRED FOR A COMPLETE SYSTEM. IRRIGATION COMPONENTS SHOWN WITHIN PAVED AREAS FOR GRAPHIC CLARITY ONLY. PLACE ALL PIPING, VALVES, QUICK COUPLING VALVES, AND OTHER IRRIGATION COMPONENTS WITHIN ADJACENT PLANTING AREAS EXCEPT WHERE PIPES CROSS PAVING. AVOID ANY CONFLICTS BETWEEN THE IRRIGATION SYSTEM, TREES, PLANTING, SITE FEATURES AND UTILITIES INCLUDING STORM DRAINAGE. ALL DIMENSIONS, QUANTITIES AND MATERIALS SHALL BE VERIFIED BY THE CONTRACTOR PRIOR TO THE START OF CONSTRUCTION.
3. DO NOT INSTALL THE IRRIGATION SYSTEM AS SHOWN ON THE DRAWINGS WHEN IT IS OBVIOUS IN THE FIELD THAT OBSTRUCTIONS, GRADE DIFFERENCES OR DIFFERENCES IN THE AREA DIMENSIONS EXIST. SUCH OBSTRUCTIONS OR DIFFERENCES SHOULD BE BROUGHT TO THE ATTENTION OF THE CITY OF SAN ANTONIO'S REPRESENTATIVE. IN THE EVENT NOTIFICATION IS NOT PERFORMED, THE CONTRACTOR SHALL ASSUME FULL RESPONSIBILITY FOR ANY REVISIONS NECESSARY.
4. INSTALLATION OF THE IRRIGATION SYSTEM UNDER THIS CONTRACT SHALL CONFORM TO ALL LOCAL, COUNTY, AND STATE PROVISIONS, INCLUDING THOSE STATED IN THE LATEST EDITION OF THE UNIFORM PLUMBING CODE, AND THE NATIONAL ELECTRIC CODE. IN THE EVENT OF DIFFERENCES BETWEEN THE CODE COMPLIANCE REQUIREMENTS OF THIS CONTRACT, THE BETTER QUALITY, HIGHER STANDARD, LARGER SIZE, AND MORE STRINGENT REQUIREMENT SHALL PREVAIL.
5. IT IS THE RESPONSIBILITY OF THE CONTRACTOR TO FAMILIARIZE HIM/HERSELF WITH ALL GRADE DIFFERENCES, LOCATION OF WALLS, ETC. CONTRACTOR SHALL COORDINATE HIS/HER WORK WITH THE GENERAL CONTRACTOR AND OTHER SUB-CONTRACTORS FOR THE LOCATION AND INSTALLATION OF PIPE SLEEVES AND CONDUITS WHERE SHOWN ON PLANS AND AS REQUIRED PRIOR TO THE PLACEMENT OF PAVING. COORDINATE WITH OTHER WORK. SLEEVES AND CONDUITS SHALL BE SIZED TO ALLOW A MINIMUM OF 25% VOID SPACE.
6. PRIOR TO ANY TRENCHING THE CONTRACTOR SHALL ASCERTAIN THE LOCATION OF ALL NEW AND EXISTING UNDERGROUND UTILITY LINES. CALL 811 A MINIMUM OF FORTY-EIGHT (48) HOURS PRIOR TO THE START OF CONSTRUCTION.
7. THE INTENT OF THIS IRRIGATION SYSTEM IS TO PROVIDE THE MINIMUM AMOUNT OF WATER TO MAINTAIN GOOD PLANT HEALTH, APPEARANCE AND REASONABLE GROWTH. THE AMOUNT OF SUPPLEMENTAL WATER A PLANT REQUIRES IS DEPENDENT ON SOIL TYPE, PLANT MATERIAL, ROOTING DEPTH, CLIMATE, SEASONAL CHANGES, SLOPES, MOUNDS, SUN, SHADE AND WIND. IT IS THE RESPONSIBILITY OF THE CONTRACTOR TO ADJUST THE IRRIGATION SCHEDULE AND ET VARIABLES AS NEEDED. IN ADDITION, THE CONTRACTOR SHALL PROVIDE SUPPLEMENTAL WATER TO ACCOMMODATE SPECIAL WATERING NEEDS OF PLANT MATERIAL THROUGH THE MAINTENANCE PERIOD. ACTUAL STATION RUN TIMES MAY VARY IN ACCORDANCE WITH VARYING SITE CONDITIONS.
8. CONTRACTOR SHALL ADJUST THE PLACEMENT OF THE DRIPLINE LAYOUT AS PER ACTUAL FIELD CONDITIONS TO ACHIEVE FULL COVERAGE OF ALL PLANTED AREAS. THE CONTRACTOR WILL BE RESPONSIBLE OF INSTALLING ADDITIONAL DRIPLINE, AS NEEDED, TO PROVIDE ADEQUATE COVERAGE, AT NO ADDITIONAL COST TO THE CITY OF SAN ANTONIO. REFER TO IRRIGATION EQUIPMENT LEGEND FOR MAXIMUM ALLOWED VERTICAL DRIPLINE SPACING.
9. IRRIGATION SYSTEM SHALL BE OPERATIONAL & COVERAGE APPROVED BY THE CITY OF SAN ANTONIO'S REPRESENTATIVE PRIOR TO INSTALLATION OF PLANTING MATERIAL.

10. THE CONTRACTOR SHALL FLUSH ALL EMISSION EQUIPMENT FOR OPTIMUM PERFORMANCE TO PROVIDE OPTIMAL EVEN DISTRIBUTION OF WATER, AND TO PROVIDE PROPER COVERAGE.
11. DRAINAGE OF IRRIGATION WATER THROUGH DRIP EMITTERS OR BUBBLERS WILL NOT BE ALLOWED. DURING THE COURSE OF CONSTRUCTION, THE CONTRACTOR SHALL INSTALL ADDITIONAL IN-LINE CHECK VALVES AS REQUIRED IN ANY AREA WHERE EMISSION DEVICES SHOW SIGNS OF DRAINAGE AFTER IRRIGATION SYSTEM HAS OPERATED FROM AN ON TO OFF POSITION. INSTALLATION OF ADDITIONAL IN-LINE CHECK VALVES SHALL BE INCLUDED IN THE BID PRICE WITHOUT ADDITIONAL COST TO THE CITY OF SAN ANTONIO.
12. MAINLINE PIPE SIZE DOWNSTREAM OF LAST PIPE SIZE CALL OUT TO BE SAME SIZE AS INLET OF PRODUCT IT SUPPLIES (BUT NOT LESS THAN 1-INCH). LATERAL PIPE SIZES DOWNSTREAM OF LAST PIPE SIZE CALL OUT TO BE SAME AS LAST PIPE SIZE CALLED OUT (BUT NOT LESS THAN 3/4-INCH).
13. SUBSURFACE EMITTER FLOW RATE, EMITTER SPACING AND LATERAL SPACING IS BASED ON TYPICAL SOILS ENCOUNTERED IN THE AREA. THE CONTRACTOR SHALL MAKE ANY MODIFICATION TO EMITTER FLOW RATE, EMITTER SPACING, AND LATERAL SPACING AS REQUIRED TO COMPLY WITH MANUFACTURER'S RECOMMENDATIONS FOR AN EVEN WETTED PATTERN, BASED ON ACTUAL SOIL ANALYSIS. REFER TO DRIPLINE MANUFACTURER RECOMMENDATIONS FOR ADDITIONAL INFORMATION. FINAL EMITTER SPACING AND FLOW RATE TO BE APPROVED BY THE CITY OF SAN ANTONIO'S REPRESENTATIVE.
14. CONTRACTOR SHALL ADJUST THE DRIPLINE LAYOUT, WHEN PLANTER SLOPE IS GREATER THAN 5 PERCENT, TO PROVIDE LATERAL ROW SPACING THAT IS 25 PERCENT GREATER WITHIN THE BOTTOM ONE-THIRD OF THE SLOPE.
15. LOCATIONS AND THE QUANTITIES OF FLUSH VALVES AND AIR/VACUUM RELIEF VALVES (AVRV) SHOWN ON PLANS ARE APPROXIMATE. CONTRACTOR IS RESPONSIBLE FOR VERIFYING HIGHEST POINTS OF EACH HYDROZONE AND LOCATING AVRVS AS REQUIRED AND FOR INSTALLING ADDITIONAL FLUSH VALVES, AS NEEDED, ACCORDING TO MANUFACTURER'S GALLONS PER HOUR REQUIREMENTS PER HYDROZONE AT NO ADDITIONAL COST TO THE CITY OF SAN ANTONIO.
16. ALL VALVES PROVIDING IRRIGATION TO SLOPES AREAS SHALL BE SCHEDULED IN MULTIPLE, SHORT CYCLES TO HELP ELIMINATE IRRIGATION WATER RUNOFF.
17. IT IS THE RESPONSIBILITY OF THE CONTRACTOR TO VERIFY AND COORDINATE AND PROVIDE THE FINAL CONNECTION OF THE CONTROLLERS AND BOOSTER PUMPS TO ITS DEDICATED POWER SOURCE. ALL ELECTRICAL WORK SHALL BE PERFORMED BY A LICENSED ELECTRICAL CONTRACTOR AND SHALL CONFORM TO THE LATEST EDITION OF THE N.E.C. AND ALL STATE AND LOCAL CODES AND REGULATIONS.
18. IT IS THE RESPONSIBILITY OF THE CONTRACTOR TO PROVIDE AND INSTALL REMOTE CONTROL WIRES FROM VALVES TO CONTROLLERS; PROVIDE AND INSTALL COMMUNICATION WIRES FROM PUMPS TO CONTROLLERS; AND MAKE FINAL CONNECTION OF REMOTE CONTROL WIRES AND COMMUNICATION WIRES AT THE CONTROLLERS, RESPECTIVELY.
19. REMOTE CONTROL WIRES SHALL BE PULLED TO FARTHEST POINTS OF THE IRRIGATION MAINLINE. WIRES TO BE LOCATED IN VALVE BOX AND SHALL BE HAVE ENDS CAPPED WITH WATERPROOF WIRE SPLICES.
20. ALL IRRIGATION EQUIPMENT SHALL BE AS LISTED OR EQUAL AS APPROVED BY THE CITY OF SAN ANTONIO'S REPRESENTATIVE.
21. SEE IRRIGATION DETAILS, TECHNICAL SPECIFICATIONS AND PLANTING PLANS AS PART OF THESE CONSTRUCTION DOCUMENTS.
22. ALL TRENCHING SHALL COMPLY WITH TREE PRESERVATION. SEE PLANTING PLANS FOR ADDITIONAL INFORMATION.

# UTILITY NOTES

1. WHERE IT IS NECESSARY TO EXCAVATE IN AREAS ADJACENT TO UTILITIES, THE CONTRACTOR SHALL POTHOLE TO CONFIRM EXACT LOCATION OF UTILITIES. EXERCISE EXTREME CARE IN EXCAVATING AND WORKING NEAR UTILITIES.
2. THE CONTRACTOR SHALL BE RESPONSIBLE FOR ALL DAMAGES TO THE UTILITIES CAUSED BY HIS/HER OPERATION OR NEGLIGENCE AND IN CASES OF INTERRUPTION OF UTILITIES BECAUSE OF OPERATION OR NEGLIGENCE. THE CONTRACTOR IS RESPONSIBLE TO HAVE THE UTILITIES IN SERVICE AS SOON AS POSSIBLE AT THE DIRECTION OF THE ENGINEER AND/OR UTILITIES REPRESENTATIVE.
3. THE COST TO REPAIR THE UTILITIES, IF DAMAGED, SHALL BE THE RESPONSIBILITY OF THE CONTRACTOR.

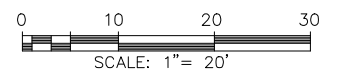

REV. NO.	DATE	DESCRIPTION	BY

**MIG** MOORE IACOFANO GOLTSMAN, INC.  
 317 LEXINGTON AVENUE, SUITE 2 TEL 210-600-9990  
 SAN ANTONIO, TEXAS, CA 78215 www.migcom.com



SAN ANTONIO | AUSTIN | HOUSTON | FORT WORTH | DALLAS  
 3000 HWY 150SP 410 | SAN ANTONIO, TX 78216 | 210.325.9999  
 TEXAS ENGINEERING FIRM #470 | TEXAS SURVEYING FIRM #1000000



CITY OF SAN ANTONIO  
**PUBLIC WORKS DEPARTMENT**

DOLOROSA

IRRIGATION NOTES

SHEET 1 OF 1

DESIGN	CHECKED	DRAWN	PROJECT NO.	SUBMITTAL	SHEET NO.
RD/AM	RD/AM	TM/RD	23-03763	70%	336

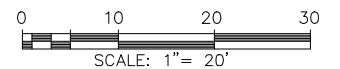
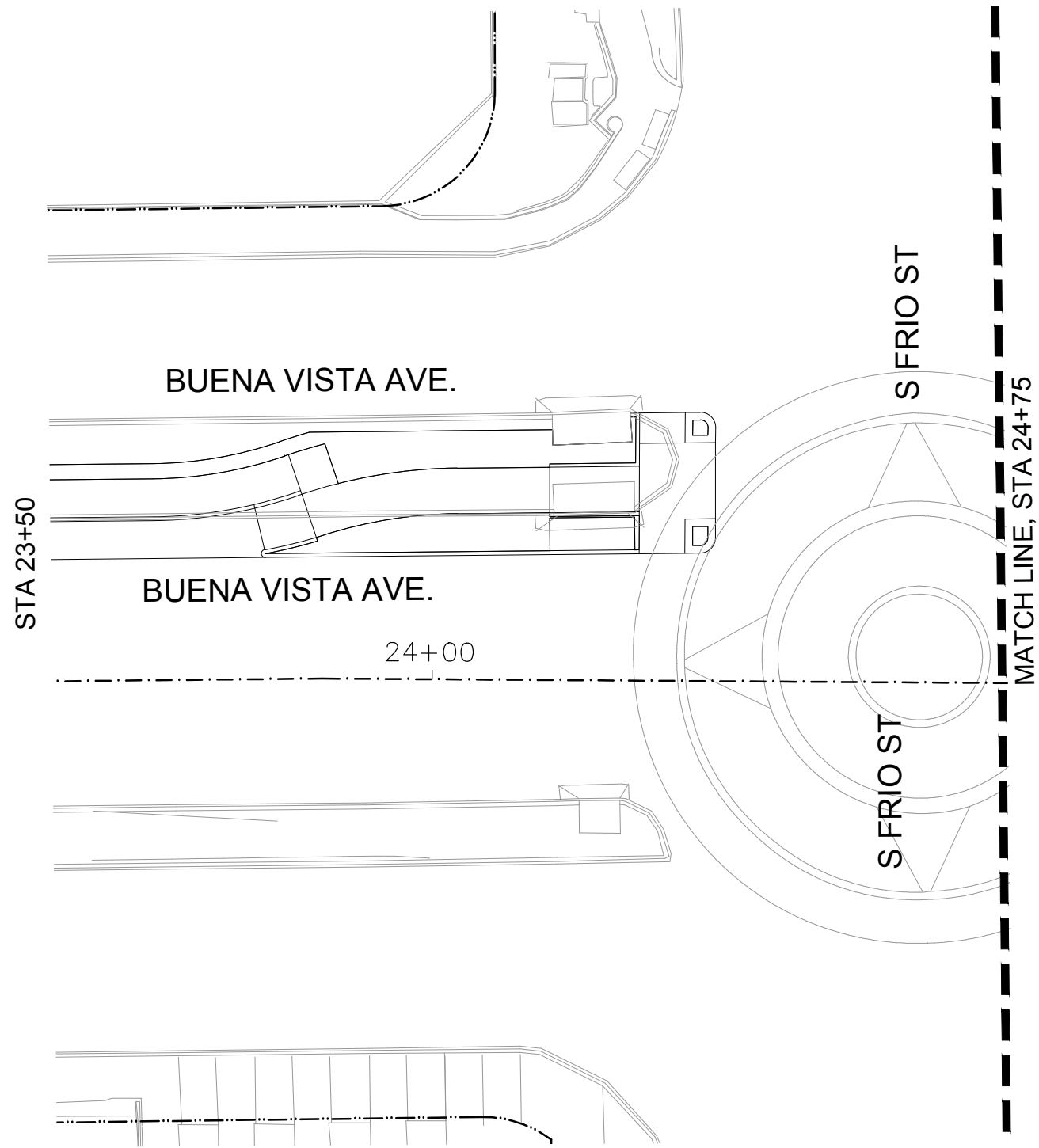

REV. NO.	DATE	DESCRIPTION	BY

**MOORE IACOFANO GOLTSMAN, INC.**  
 317 LEXINGTON AVENUE, SUITE 2  
 SAN ANTONIO, TEXAS, CA 78215  
 TEL 210-600-9990  
 www.migcom.com



SAN ANTONIO | AUSTIN | HOUSTON | FORT WORTH | DALLAS  
 3800 HWY 149P-410 | SAN ANTONIO, TX 78218 | 210.325.9999  
 TEXAS ENGINEERING FIRM #170 | TEXAS SURVEYING FIRM #10000000



CITY OF SAN ANTONIO  
**PUBLIC WORKS DEPARTMENT**

DOLOROSA

## IRRIGATION PLAN

STA 23+00 TO STA 24+75

SHEET 1 OF 16

DESIGN	CHECKED	DRAWN	PROJECT NO.	SUBMITTAL	SHEET NO.
RD/AM	RD/AM	TM/RD	23-03763	70%	337

### GENERAL PLAN NOTES

- IRRIGATION PLANS ARE GENERALLY DIAGRAMMATIC AND INDICATIVE OF THE WORK TO BE INSTALLED. IT IS THE INTENT OF THIS DESIGN THAT ALL MAINLINE AND LATERAL PIPES, VALVES, ETC., AND OTHER IRRIGATION SYSTEM APPURTENANCES BE INSTALL IN LANDSCAPE AREAS WHEREVER POSSIBLE AND WITHIN THE PUBLIC RIGHT-OF-WAY.
- THE CONTRACTOR SHALL ROUTE ALL IRRIGATION MAINLINE AND LATERAL PIPE AND SLEEVES AROUND ALL SERVICE LINES, NEW AND EXISTING TREES, UTILITIES, STORM DRAINAGE FACILITIES, ETC., IN ORDER TO AVOID ANY CONFLICTS. INSTALL IRRIGATION PIPE BELOW STORM DRAINAGE PIPES WHERE REQUIRED AND INSTRUCTED.

### GENERAL PLAN LEGEND

SLEEVING: INSTALL IN LOCATIONS AS SHOWN ON PLAN. REFER TO PIPE/WIRE SLEEVING CHART ON THIS SHEET FOR SIZE AND TYPE.

- (#) M = MAINLINE SLEEVE
- (#) L = LATERAL SLEEVE
- (#) W = WIRING CONDUIT
- — — — — LIMIT OF WORK

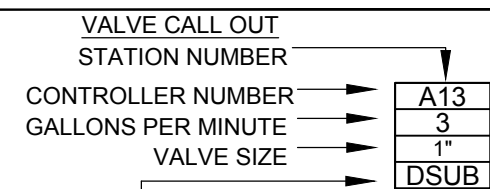

- DSUB - SUBSURFACE DRIP IRRIGATION
- TBUB - ROOT WATERING TREE BUBBLER
- TRNG - ROOT WATER TREE RING

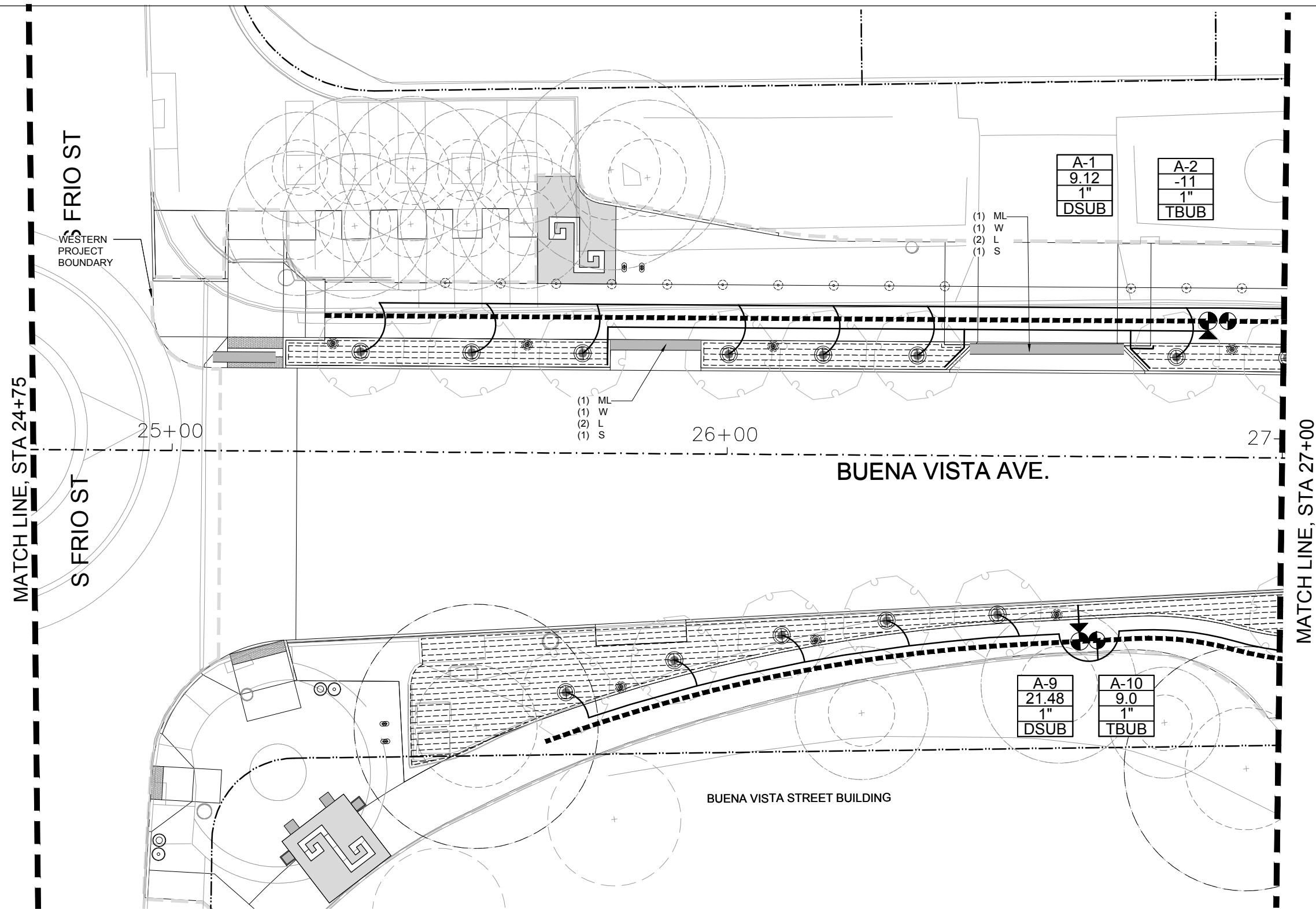

**GENERAL PLAN NOTES**

- IRRIGATION PLANS ARE GENERALLY DIAGRAMMATIC AND INDICATIVE OF THE WORK TO BE INSTALLED. IT IS THE INTENT OF THIS DESIGN THAT ALL MAINLINE AND LATERAL PIPES, VALVES, ETC., AND OTHER IRRIGATION SYSTEM APPURTENANCES BE INSTALLED IN LANDSCAPE AREAS WHEREVER POSSIBLE AND WITHIN THE PUBLIC RIGHT-OF-WAY.
- THE CONTRACTOR SHALL ROUTE ALL IRRIGATION MAINLINE AND LATERAL PIPE AND SLEEVES AROUND ALL SERVICE LINES, NEW AND EXISTING TREES, UTILITIES, STORM DRAINAGE FACILITIES, ETC., IN ORDER TO AVOID ANY CONFLICTS. INSTALL IRRIGATION PIPE BELOW STORM DRAINAGE PIPES WHERE REQUIRED AND INSTRUCTED.

**GENERAL PLAN LEGEND**

SLEEVING: INSTALL IN LOCATIONS AS SHOWN ON PLAN. REFER TO PIPE/WIRE SLEEVING CHART ON THIS SHEET FOR SIZE AND TYPE.

- (#) M = MAINLINE SLEEVE
- (#) L = LATERAL SLEEVE
- (#) W = WIRING CONDUIT
- LIMIT OF WORK

**VALVE CALL OUT**

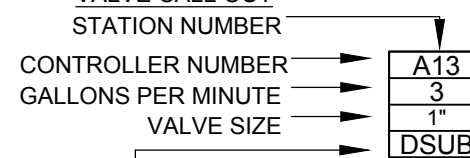

- DSUB - SUBSURFACE DRIP IRRIGATION
- TBUB - ROOT WATERING TREE BUBBLER
- TRNG - ROOT WATER TREE RING

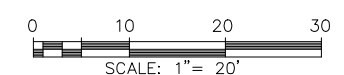

REV. NO.	DATE	DESCRIPTION	BY

**MIG** MOORE IACOFANO GOLTSMAN, INC.  
317 LEXINGTON AVENUE, SUITE 2  
SAN ANTONIO, TEXAS, CA 78215 TEL 210-600-9990  
www.migcom.com



SAN ANTONIO | AUSTIN | HOUSTON | FORT WORTH | DALLAS  
3600 HWY 150P-418 | SAN ANTONIO, TX 78216 | 210.325.9999  
TEXAS ENGINEERING FIRM #170 | TEXAS SURVEYING FIRM #1002000



DOLOROSA

**IRRIGATION PLAN**

STA 24+75 TO STA 27+00

SHEET 2 OF 16

DESIGN	CHECKED	DRAWN	PROJECT NO.	SUBMITTAL	SHEET NO.
RD/AM	RD/AM	TM/RD	23-03763	70%	338



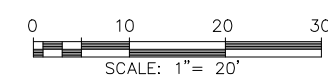
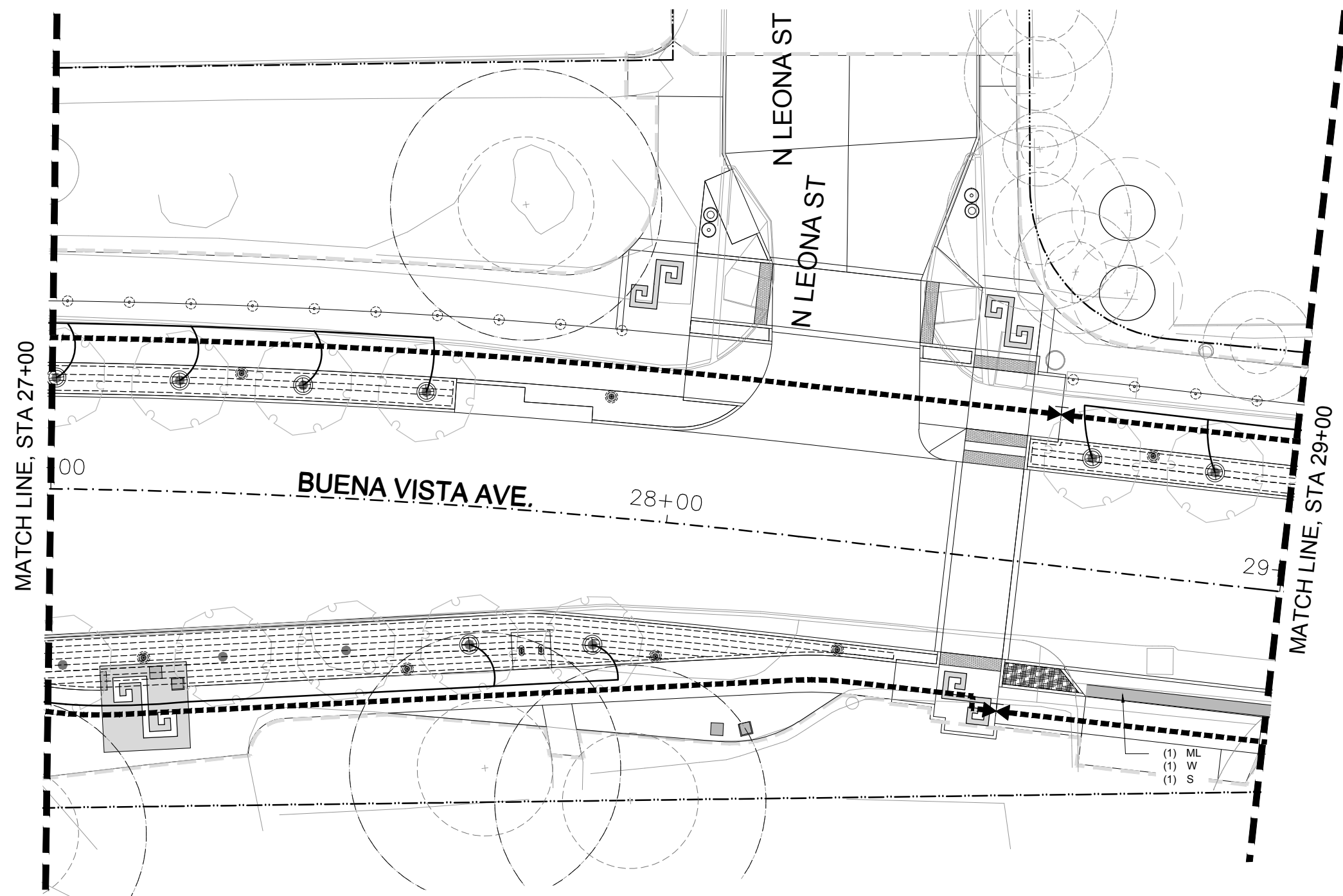

REV. NO.	DATE	DESCRIPTION	BY
<b>MOORE IACOFANO GOLTSMAN, INC.</b> <small>317 LEXINGTON AVENUE, SUITE 2  SAN ANTONIO, TEXAS, CA 78215  TEL 210-600-9990  www.migcom.com</small>			



SAN ANTONIO | AUSTIN | HOUSTON | FORT WORTH | DALLAS  
3000 HWY 150P-410 | SAN ANTONIO, TX 78216 | 210.325.0000  
TEXAS ENGINEERING FIRM #170 | TEXAS SURVEYING FIRM #10000000



**CITY OF SAN ANTONIO  
PUBLIC WORKS DEPARTMENT**

DOLOROSA

## IRRIGATION PLAN

STA 27+00 TO STA 29+00

SHEET 3 OF 16

DESIGN	CHECKED	DRAWN	PROJECT NO.	SUBMITTAL	SHEET NO.
RD/AM	RD/AM	TM/RD	23-03763	70%	339

### GENERAL PLAN NOTES

- IRRIGATION PLANS ARE GENERALLY DIAGRAMMATIC AND INDICATIVE OF THE WORK TO BE INSTALLED. IT IS THE INTENT OF THIS DESIGN THAT ALL MAINLINE AND LATERAL PIPES, VALVES, ETC., AND OTHER IRRIGATION SYSTEM APPURTENANCES BE INSTALLED IN LANDSCAPE AREAS WHEREVER POSSIBLE AND WITHIN THE PUBLIC RIGHT-OF-WAY.
- THE CONTRACTOR SHALL ROUTE ALL IRRIGATION MAINLINE AND LATERAL PIPE AND SLEEVES AROUND ALL SERVICE LINES, NEW AND EXISTING TREES, UTILITIES, STORM DRAINAGE FACILITIES, ETC., IN ORDER TO AVOID ANY CONFLICTS. INSTALL IRRIGATION PIPE BELOW STORM DRAINAGE PIPES WHERE REQUIRED AND INSTRUCTED.

### GENERAL PLAN LEGEND

SLEEVING: INSTALL IN LOCATIONS AS SHOWN ON PLAN. REFER TO PIPE/WIRE SLEEVING CHART ON THIS SHEET FOR SIZE AND TYPE.

- (#) M = MAINLINE SLEEVE
- (#) L = LATERAL SLEEVE
- (#) W = WIRING CONDUIT
- LIMIT OF WORK

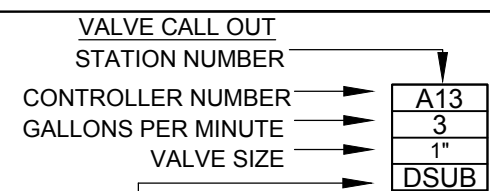

- DSUB - SUBSURFACE DRIP IRRIGATION
- TBUB - ROOT WATERING TREE BUBBLER
- TRNG - ROOT WATER TREE RING

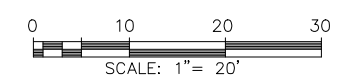
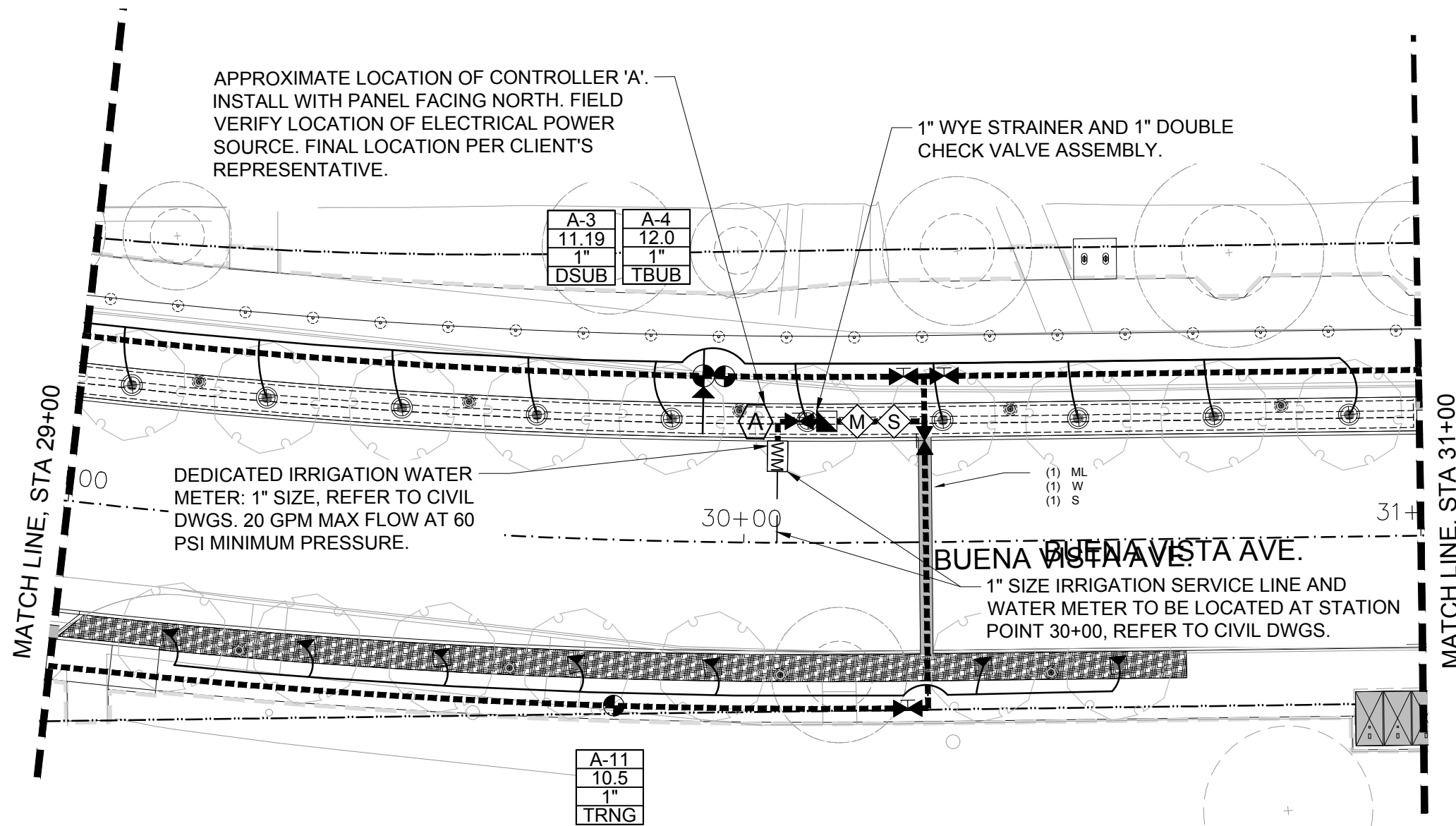

REV. NO.	DATE	DESCRIPTION	BY

**MOORE IACOFANO GOLTSMAN, INC.**  
 317 LEXINGTON AVENUE, SUITE 2 | TEL 210-600-9990  
 SAN ANTONIO, TEXAS, CA 78215 | www.migcom.com



SAN ANTONIO | AUSTIN | HOUSTON | FORT WORTH | DALLAS  
 3800 HWY 190P-418 | SAN ANTONIO, TX 78216 | 210.325.0000  
 TEXAS ENGINEERING FIRM #170 | TEXAS SURVEYING FIRM #10000000



CITY OF SAN ANTONIO  
**PUBLIC WORKS DEPARTMENT**

DOLOROSA

IRRIGATION PLAN

STA 29+00 TO STA 31+00

SHEET 4 OF 16

DESIGN	CHECKED	DRAWN	PROJECT NO.	SUBMITTAL	SHEET NO.
RD/AM	RD/AM	TM/RD	23-03763	70%	340

**GENERAL PLAN NOTES**

- IRRIGATION PLANS ARE GENERALLY DIAGRAMMATIC AND INDICATIVE OF THE WORK TO BE INSTALLED. IT IS THE INTENT OF THIS DESIGN THAT ALL MAINLINE AND LATERAL PIPES, VALVES, ETC., AND OTHER IRRIGATION SYSTEM APPURTENANCES BE INSTALL IN LANDSCAPE AREAS WHEREVER POSSIBLE AND WITHIN THE PUBLIC RIGHT-OF-WAY.
- THE CONTRACTOR SHALL ROUTE ALL IRRIGATION MAINLINE AND LATERAL PIPE AND SLEEVES AROUND ALL SERVICE LINES, NEW AND EXISTING TREES, UTILITIES, STORM DRAINAGE FACILITIES, ETC., IN ORDER TO AVOID ANY CONFLICTS. INSTALL IRRIGATION PIPE BELOW STORM DRAINAGE PIPES WHERE REQUIRED AND INSTRUCTED.

**GENERAL PLAN LEGEND**

SLEEVING: INSTALL IN LOCATIONS AS SHOWN ON PLAN. REFER TO PIPE/WIRE SLEEVING CHART ON THIS SHEET FOR SIZE AND TYPE.

- (#) M = MAINLINE SLEEVE
- (#) L = LATERAL SLEEVE
- (#) W = WIRING CONDUIT
- LIMIT OF WORK

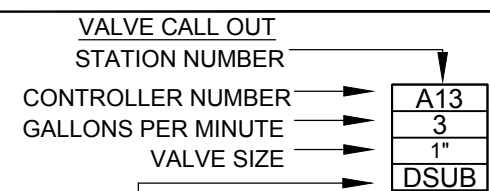

- DSUB - SUBSURFACE DRIP IRRIGATION
- TBUB - ROOT WATERING TREE BUBBLER
- TRNG - ROOT WATER TREE RING

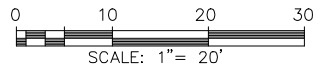
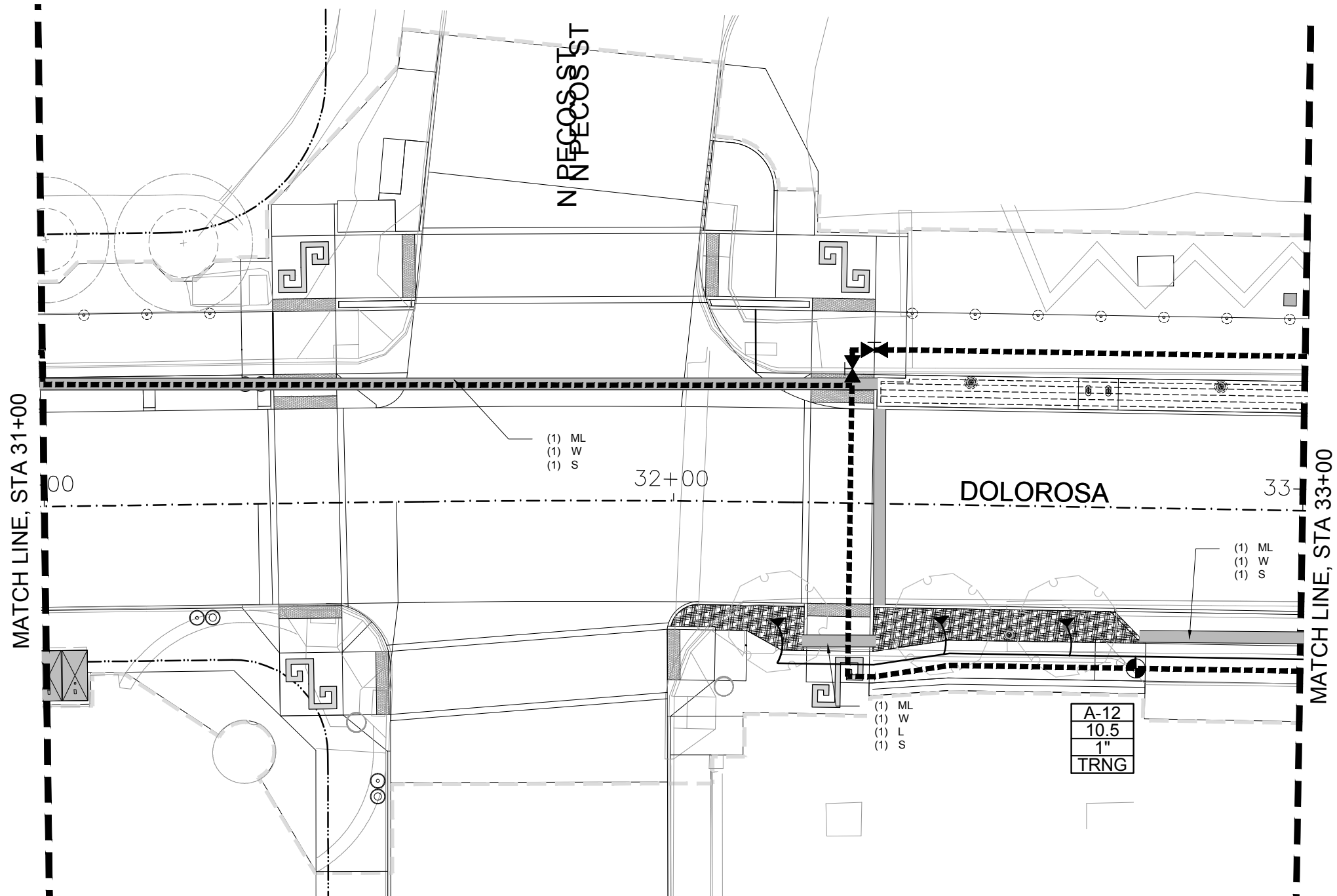

REV. NO.	DATE	DESCRIPTION	BY
<b>MOORE IACOFANO GOLTSMAN, INC.</b> <small>317 LEXINGTON AVENUE, SUITE 2  SAN ANTONIO, TEXAS, CA 78215 TEL 210-600-9990  www.migcom.com</small>			



SAN ANTONIO | AUSTIN | HOUSTON | FORT WORTH | DALLAS  
3800 HWY 150P-418 | SAN ANTONIO, TX 78216 | 210.325.9999  
TEXAS ENGINEERING FIRM #170 | TEXAS SURVEYING FIRM #10020000



**CITY OF SAN ANTONIO  
PUBLIC WORKS DEPARTMENT**

DOLOROSA

**IRRIGATION PLAN**

STA 31+00 TO STA 33+00

SHEET 5 OF 16

DESIGN	CHECKED	DRAWN	PROJECT NO.	SUBMITTAL	SHEET NO.
RD/AM	RD/AM	TM/RD	23-03763	70%	341

**GENERAL PLAN NOTES**

- IRRIGATION PLANS ARE GENERALLY DIAGRAMMATIC AND INDICATIVE OF THE WORK TO BE INSTALLED. IT IS THE INTENT OF THIS DESIGN THAT ALL MAINLINE AND LATERAL PIPES, VALVES, ETC., AND OTHER IRRIGATION SYSTEM APPURTENANCES BE INSTALL IN LANDSCAPE AREAS WHEREVER POSSIBLE AND WITHIN THE PUBLIC RIGHT-OF-WAY.
- THE CONTRACTOR SHALL ROUTE ALL IRRIGATION MAINLINE AND LATERAL PIPE AND SLEEVES AROUND ALL SERVICE LINES, NEW AND EXISTING TREES, UTILITIES, STORM DRAINAGE FACILITIES, ETC., IN ORDER TO AVOID ANY CONFLICTS. INSTALL IRRIGATION PIPE BELOW STORM DRAINAGE PIPES WHERE REQUIRED AND INSTRUCTED.

**GENERAL PLAN LEGEND**

SLEEVING: INSTALL IN LOCATIONS AS SHOWN ON PLAN. REFER TO PIPE/WIRE SLEEVING CHART ON THIS SHEET FOR SIZE AND TYPE.

- (#) M = MAINLINE SLEEVE
- (#) L = LATERAL SLEEVE
- (#) W = WIRING CONDUIT
- LIMIT OF WORK

**VALVE CALL OUT**

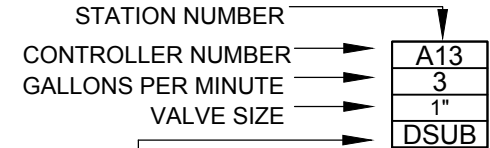

- DSUB - SUBSURFACE DRIP IRRIGATION
- TBUB - ROOT WATERING TREE BUBBLER
- TRNG - ROOT WATER TREE RING

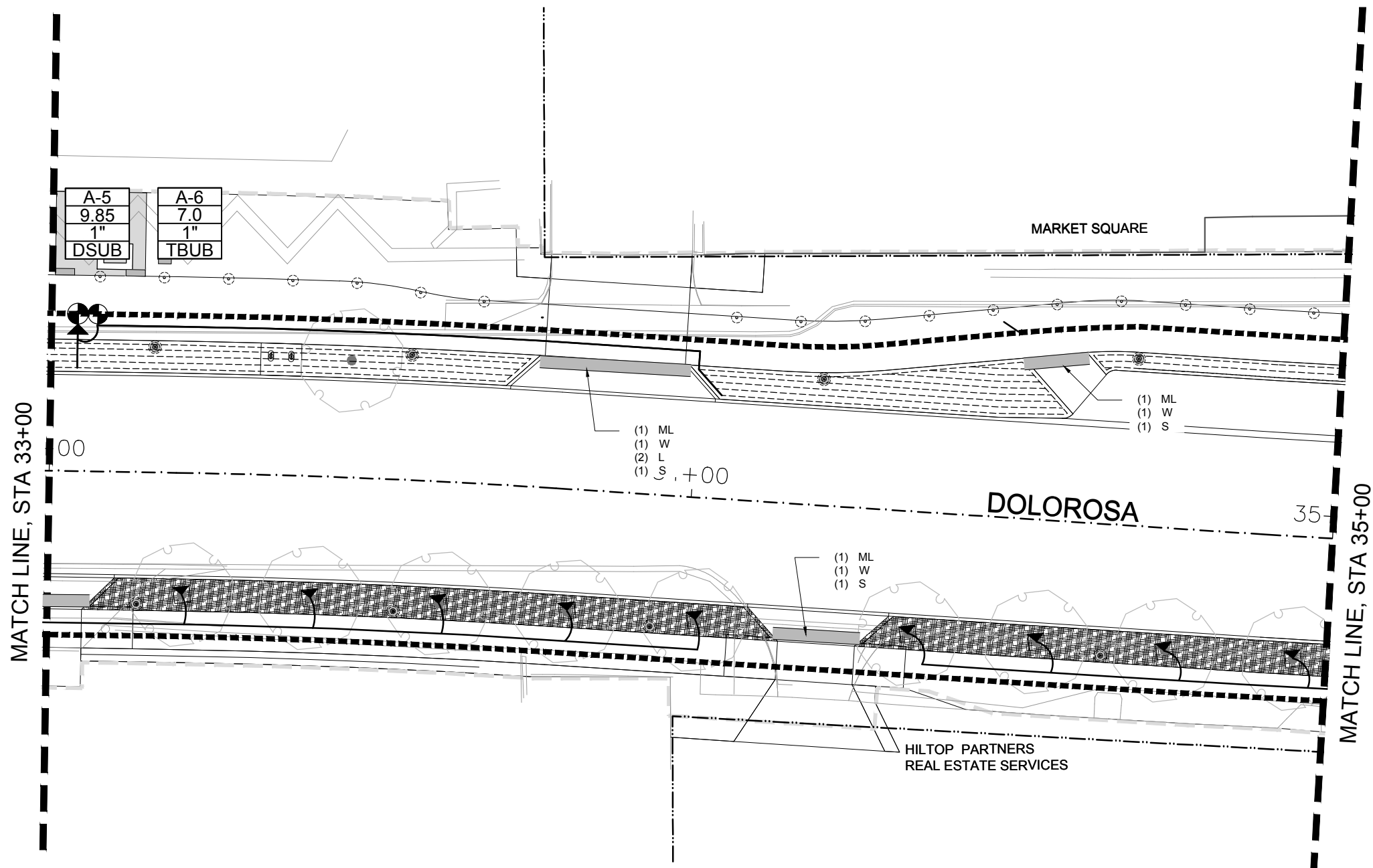

MATCH LINE, STA 33+00

MATCH LINE, STA 35+00

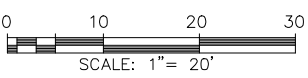

REV. NO.	DATE	DESCRIPTION	BY

**MOORE IACOFANO GOLTSMAN, INC.**  
 317 LEXINGTON AVENUE, SUITE 2  
 SAN ANTONIO, TEXAS, CA 78215  
 TEL 210-600-9990  
 www.migcom.com



SAN ANTONIO | AUSTIN | HOUSTON | FORT WORTH | DALLAS  
 3800 HWY 150P-416 | SAN ANTONIO, TX 78216 | 210.325.0000  
 TEXAS ENGINEERING FIRM #170 | TEXAS SURVEYING FIRM #10000000



DOLOROSA  
 IRRIGATION PLAN

STA 33+00 TO STA 35+00

SHEET 6 OF 16

DESIGN	CHECKED	DRAWN	PROJECT NO.	SUBMITTAL	SHEET NO.
RD/AM	RD/AM	TM/RD	23-03763	70%	342

**GENERAL PLAN NOTES**

- IRRIGATION PLANS ARE GENERALLY DIAGRAMMATIC AND INDICATIVE OF THE WORK TO BE INSTALLED. IT IS THE INTENT OF THIS DESIGN THAT ALL MAINLINE AND LATERAL PIPES, VALVES, ETC., AND OTHER IRRIGATION SYSTEM APPURTENANCES BE INSTALL IN LANDSCAPE AREAS WHEREVER POSSIBLE AND WITHIN THE PUBLIC RIGHT-OF-WAY.
- THE CONTRACTOR SHALL ROUTE ALL IRRIGATION MAINLINE AND LATERAL PIPE AND SLEEVES AROUND ALL SERVICE LINES, NEW AND EXISTING TREES, UTILITIES, STORM DRAINAGE FACILITIES, ETC., IN ORDER TO AVOID ANY CONFLICTS. INSTALL IRRIGATION PIPE BELOW STORM DRAINAGE PIPES WHERE REQUIRED AND INSTRUCTED.

**GENERAL PLAN LEGEND**

SLEEVING: INSTALL IN LOCATIONS AS SHOWN ON PLAN. REFER TO PIPE/WIRE SLEEVING CHART ON THIS SHEET FOR SIZE AND TYPE.

(#) M = MAINLINE SLEEVE  
 (#) L = LATERAL SLEEVE  
 (#) W = WIRING CONDUIT  
 - - - - - LIMIT OF WORK

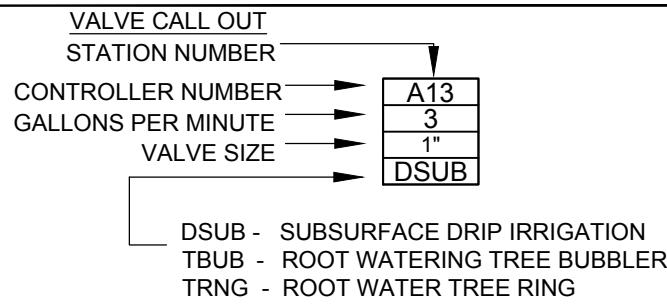

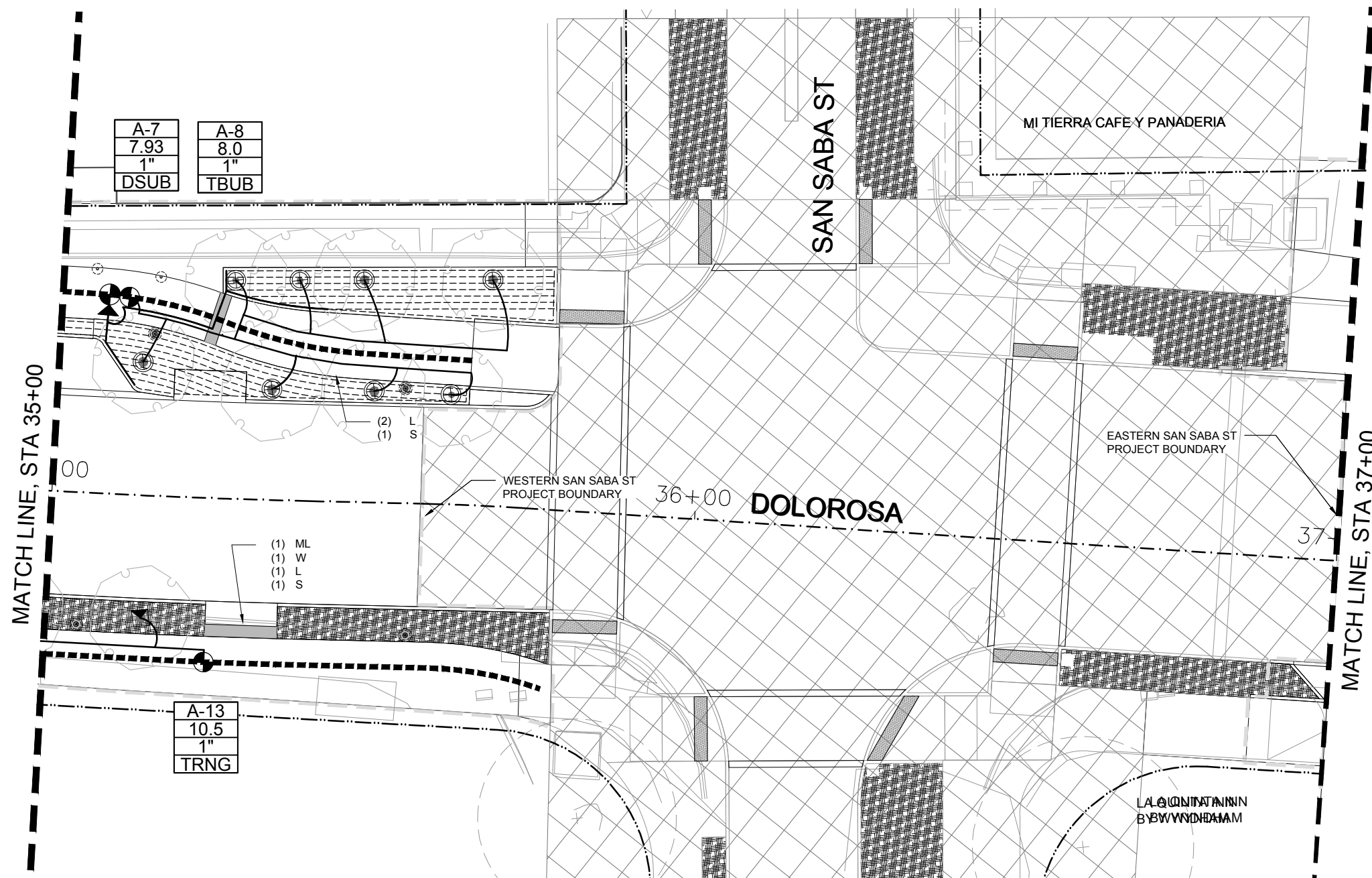

A-7	A-8
7.93	8.0
1"	1"
DSUB	TBUB

A-13
10.5
1"
TRNG

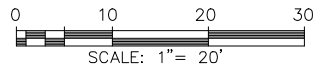

REV. NO.	DATE	DESCRIPTION	BY
<b>MOORE IACOFANO GOLTSMAN, INC.</b> <small>317 LEXINGTON AVENUE, SUITE 2  SAN ANTONIO, TEXAS, CA 78215  TEL 210-600-9990  www.migcom.com</small>			



SAN ANTONIO | AUSTIN | HOUSTON | FORT WORTH | DALLAS  
3000 HWY 150P-410 | SAN ANTONIO, TX 78216 | 210.325.9999  
TEXAS ENGINEERING FIRM #170 | TEXAS SURVEYING FIRM #10000000



**CITY OF SAN ANTONIO  
PUBLIC WORKS DEPARTMENT**

**DOLOROSA**

**IRRIGATION PLAN**

STA 35+00 TO STA 37+00

SHEET 7 OF 16

DESIGN	CHECKED	DRAWN	PROJECT NO.	SUBMITTAL	SHEET NO.
RD/AM	RD/AM	TM/RD	23-03763	70%	343

**GENERAL PLAN NOTES**

- IRRIGATION PLANS ARE GENERALLY DIAGRAMMATIC AND INDICATIVE OF THE WORK TO BE INSTALLED. IT IS THE INTENT OF THIS DESIGN THAT ALL MAINLINE AND LATERAL PIPES, VALVES, ETC., AND OTHER IRRIGATION SYSTEM APPURTENANCES BE INSTALL IN LANDSCAPE AREAS WHEREVER POSSIBLE AND WITHIN THE PUBLIC RIGHT-OF-WAY.
- THE CONTRACTOR SHALL ROUTE ALL IRRIGATION MAINLINE AND LATERAL PIPE AND SLEEVES AROUND ALL SERVICE LINES, NEW AND EXISTING TREES, UTILITIES, STORM DRAINAGE FACILITIES, ETC., IN ORDER TO AVOID ANY CONFLICTS. INSTALL IRRIGATION PIPE BELOW STORM DRAINAGE PIPES WHERE REQUIRED AND INSTRUCTED.

**GENERAL PLAN LEGEND**

- SLEEVING: INSTALL IN LOCATIONS AS SHOWN ON PLAN. REFER TO PIPE/WIRE SLEEVING CHART ON THIS SHEET FOR SIZE AND TYPE.
- (#) M = MAINLINE SLEEVE
  - (#) L = LATERAL SLEEVE
  - (#) W = WIRING CONDUIT
  - LIMIT OF WORK

**VALVE CALL OUT**

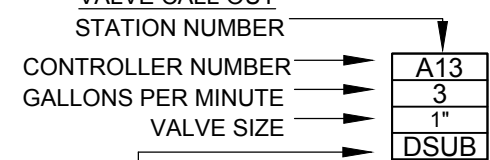

- DSUB - SUBSURFACE DRIP IRRIGATION
- TBUB - ROOT WATERING TREE BUBBLER
- TRNG - ROOT WATER TREE RING

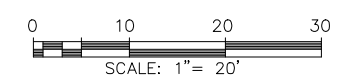
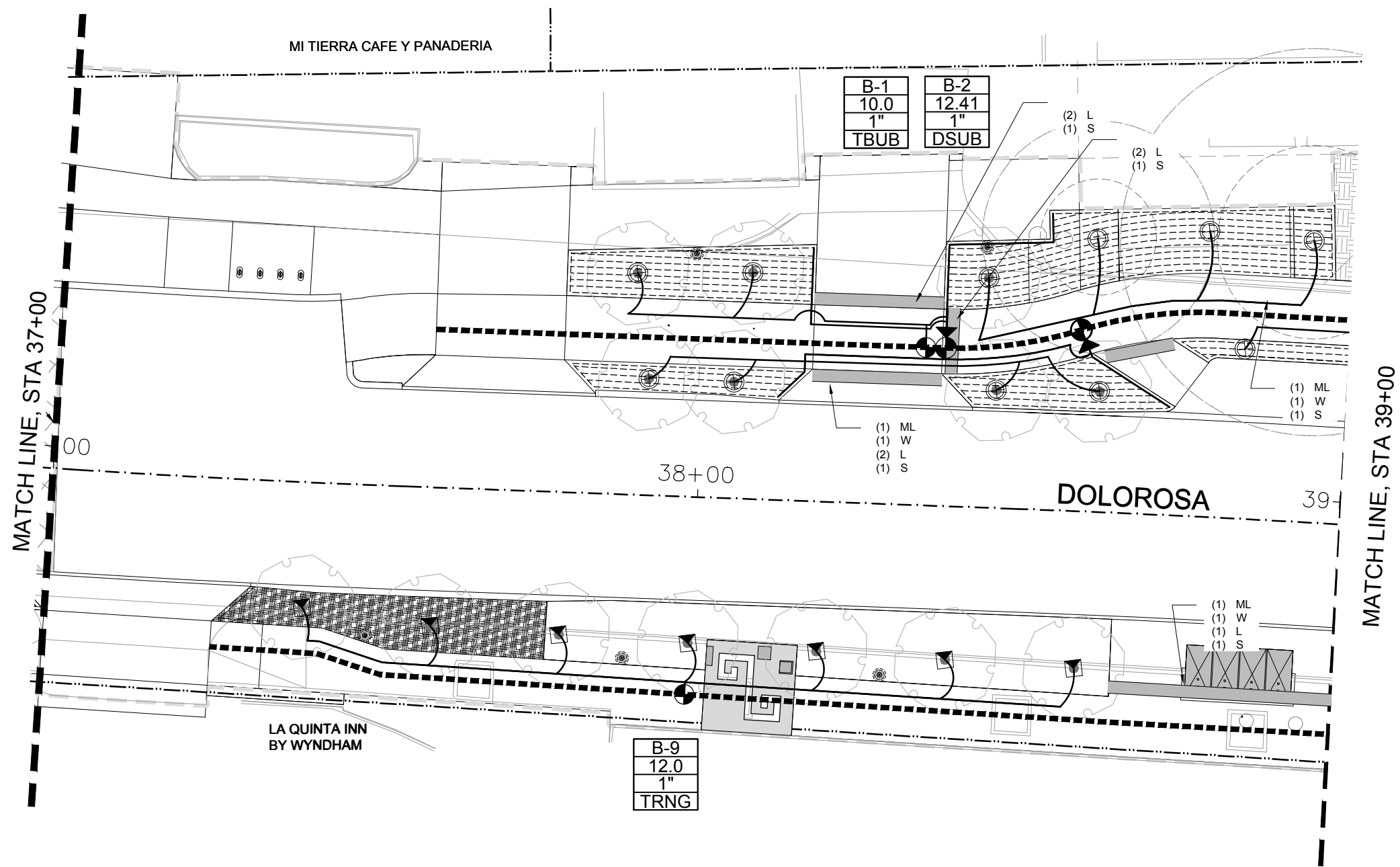

REV. NO.	DATE	DESCRIPTION	BY

**MOORE IACOFANO GOLTSMAN, INC.**  
 317 LEXINGTON AVENUE, SUITE 2  
 SAN ANTONIO, TEXAS, CA 78215  
 TEL 210-600-9990  
 www.migcom.com



SAN ANTONIO | AUSTIN | HOUSTON | FORT WORTH | DALLAS  
 3800 HWY 198P-418 | SAN ANTONIO, TX 78218 | 210.325.9990  
 TEXAS ENGINEERING FIRM #479 | TEXAS SURVEYING FIRM #10028899



CITY OF SAN ANTONIO  
**PUBLIC WORKS DEPARTMENT**

DOLOROSA

IRRIGATION PLAN

STA 37+00 TO STA 39+00

SHEET 8 OF 16

DESIGN	CHECKED	DRAWN	PROJECT NO.	SUBMITTAL	SHEET NO.
RD/AM	RD/AM	TM/RD	23-03763	70%	344

**GENERAL PLAN NOTES**

- IRRIGATION PLANS ARE GENERALLY DIAGRAMMATIC AND INDICATIVE OF THE WORK TO BE INSTALLED. IT IS THE INTENT OF THIS DESIGN THAT ALL MAINLINE AND LATERAL PIPES, VALVES, ETC., AND OTHER IRRIGATION SYSTEM APPURTENANCES BE INSTALLED IN LANDSCAPE AREAS WHEREVER POSSIBLE AND WITHIN THE PUBLIC RIGHT-OF-WAY.
- THE CONTRACTOR SHALL ROUTE ALL IRRIGATION MAINLINE AND LATERAL PIPE AND SLEEVES AROUND ALL SERVICE LINES, NEW AND EXISTING TREES, UTILITIES, STORM DRAINAGE FACILITIES, ETC., IN ORDER TO AVOID ANY CONFLICTS. INSTALL IRRIGATION PIPE BELOW STORM DRAINAGE PIPES WHERE REQUIRED AND INSTRUCTED.

**GENERAL PLAN LEGEND**

SLEEVING: INSTALL IN LOCATIONS AS SHOWN ON PLAN. REFER TO PIPE/WIRE SLEEVING CHART ON THIS SHEET FOR SIZE AND TYPE.

- (#) M = MAINLINE SLEEVE
- (#) L = LATERAL SLEEVE
- (#) W = WIRING CONDUIT
- — — — — LIMIT OF WORK

**VALVE CALL OUT**

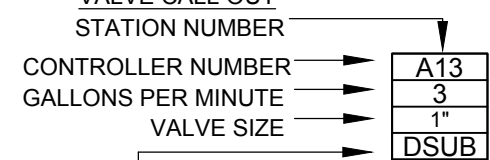

- DSUB - SUBSURFACE DRIP IRRIGATION
- TBUB - ROOT WATERING TREE BUBBLER
- TRNG - ROOT WATER TREE RING

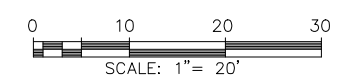
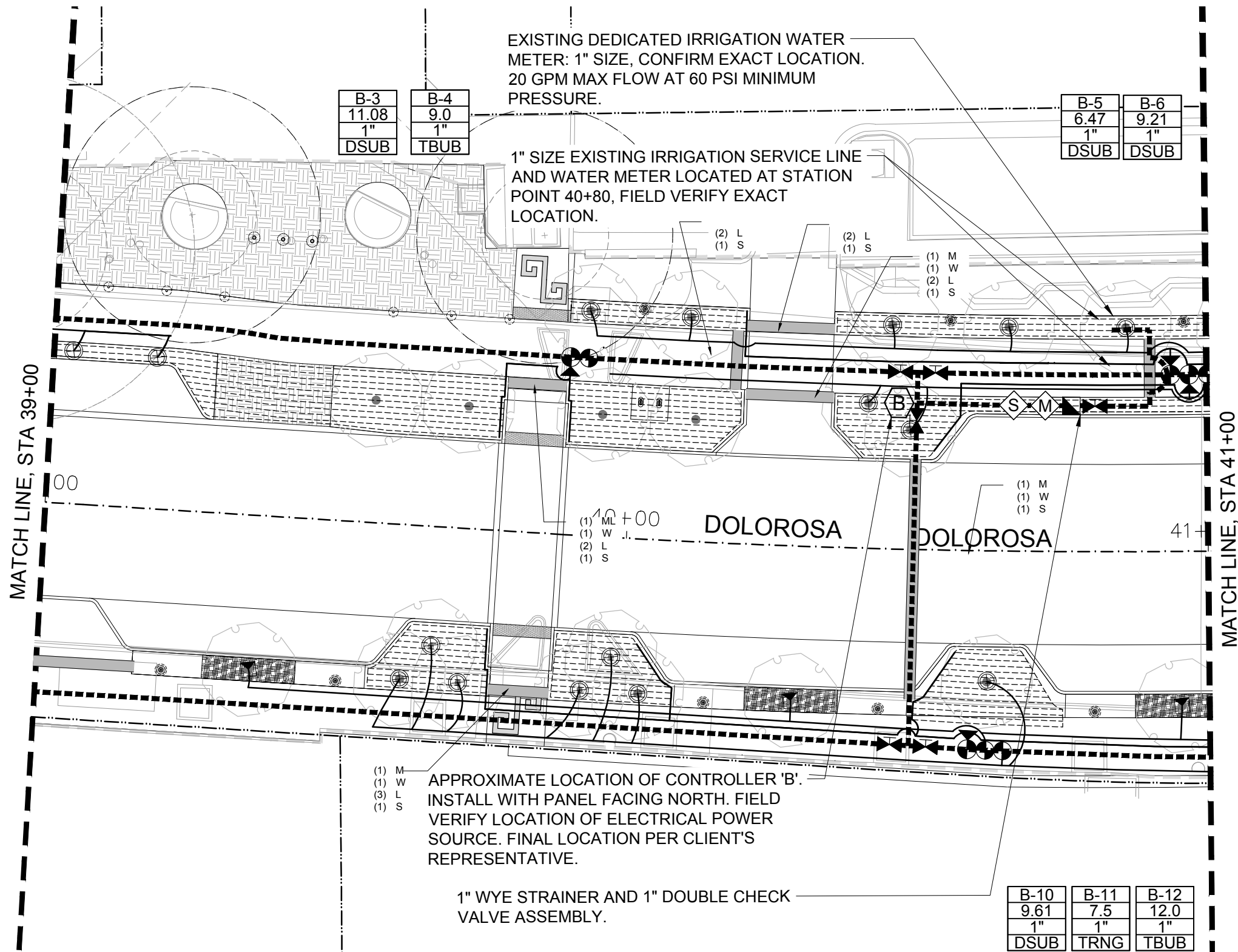

REV. NO.	DATE	DESCRIPTION	BY

**MIG** MOORE IACOFANO GOLTSMAN, INC.  
317 LEXINGTON AVENUE, SUITE 2  
SAN ANTONIO, TEXAS, CA 78215  
TEL 210-600-9990  
www.migcom.com



SAN ANTONIO | AUSTIN | HOUSTON | FORT WORTH | DALLAS  
3800 HWY 150P-410 | SAN ANTONIO, TX 78216 | 210.325.9999  
TEXAS ENGINEERING FIRM #170 | TEXAS SURVEYING FIRM #10020000



DOLOROSA  
IRRIGATION PLAN

STA 39+00 TO STA 41+00

SHEET 9 OF 16

**GENERAL PLAN NOTES**

- IRRIGATION PLANS ARE GENERALLY DIAGRAMMATIC AND INDICATIVE OF THE WORK TO BE INSTALLED. IT IS THE INTENT OF THIS DESIGN THAT ALL MAINLINE AND LATERAL PIPES, VALVES, ETC., AND OTHER IRRIGATION SYSTEM APPURTENANCES BE INSTALL IN LANDSCAPE AREAS WHEREVER POSSIBLE AND WITHIN THE PUBLIC RIGHT-OF-WAY.
- THE CONTRACTOR SHALL ROUTE ALL IRRIGATION MAINLINE AND LATERAL PIPE AND SLEEVES AROUND ALL SERVICE LINES, NEW AND EXISTING TREES, UTILITIES, STORM DRAINAGE FACILITIES, ETC., IN ORDER TO AVOID ANY CONFLICTS. INSTALL IRRIGATION PIPE BELOW STORM DRAINAGE PIPES WHERE REQUIRED AND INSTRUCTED.

**GENERAL PLAN LEGEND**

- SLEEVING: INSTALL IN LOCATIONS AS SHOWN ON PLAN. REFER TO PIPE/WIRE SLEEVING CHART ON THIS SHEET FOR SIZE AND TYPE.
- (#) M = MAINLINE SLEEVE
  - (#) L = LATERAL SLEEVE
  - (#) W = WIRING CONDUIT
  - LIMIT OF WORK

**VALVE CALL OUT**

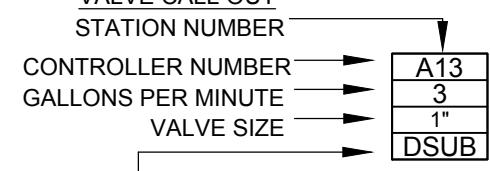

- DSUB - SUBSURFACE DRIP IRRIGATION
- TBUB - ROOT WATERING TREE BUBBLER
- TRNG - ROOT WATER TREE RING

DESIGN	CHECKED	DRAWN	PROJECT NO.	SUBMITTAL	SHEET NO.
RD/AM	RD/AM	TM/RD	23-03763	70%	345

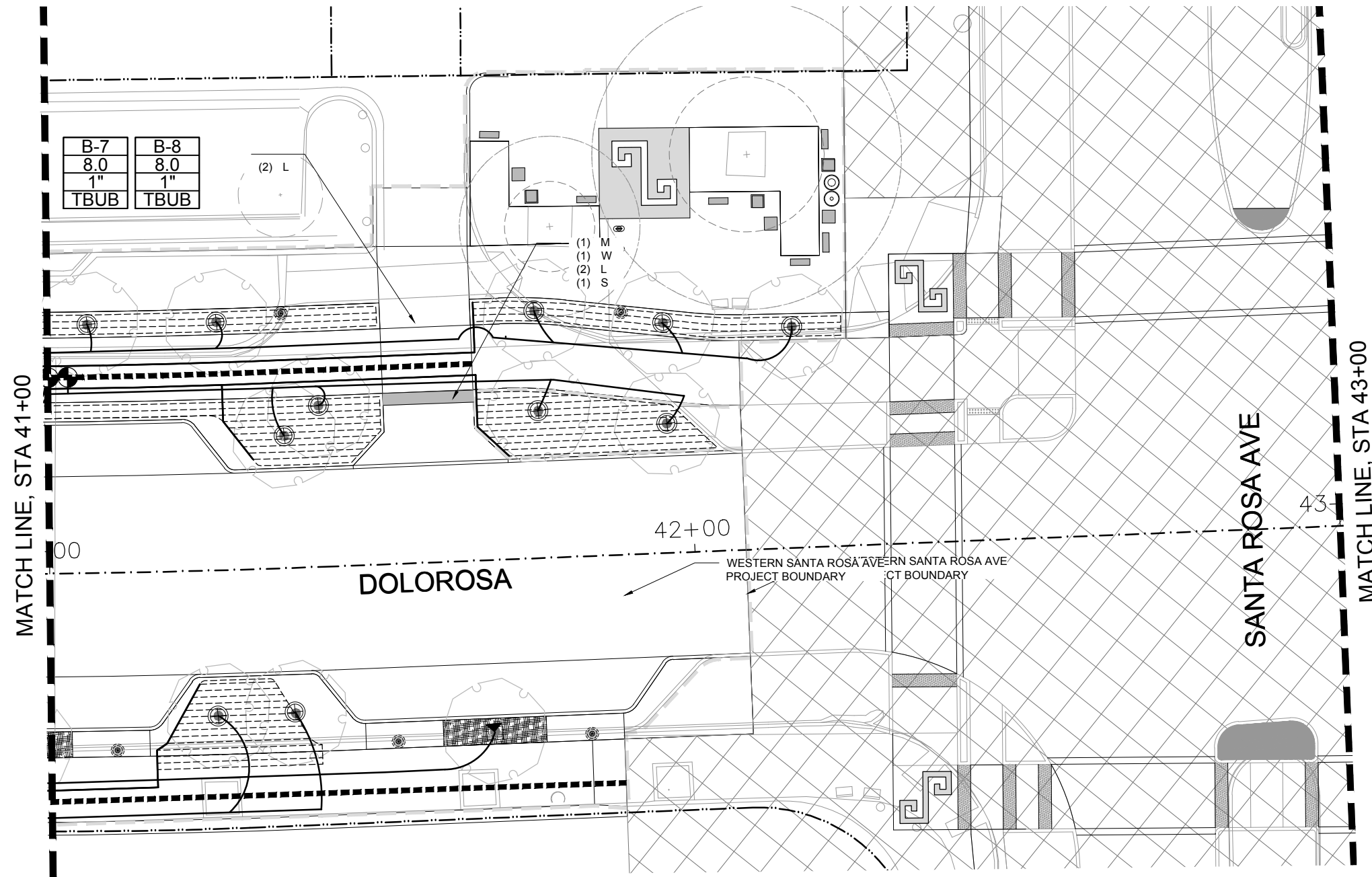

B-7	B-8
8.0	8.0
1"	1"
TBUB	TBUB

(1) M  
(1) W  
(2) L  
(1) S

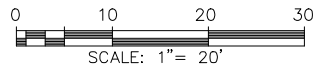

REV. NO.	DATE	DESCRIPTION	BY
<b>MOORE IACOFANO GOLTSMAN, INC.</b> <small>317 LEXINGTON AVENUE, SUITE 2  SAN ANTONIO, TEXAS, CA 78215  TEL 210-600-9990  www.migcom.com</small>			



SAN ANTONIO | AUSTIN | HOUSTON | FORT WORTH | DALLAS  
3800 HWY 198P-418 | SAN ANTONIO, TX 78218 | 210.925.9999  
TEXAS ENGINEERING FIRM #170 | TEXAS SURVEYING FIRM #10000000



**CITY OF SAN ANTONIO  
PUBLIC WORKS DEPARTMENT**

DOLOROSA

**IRRIGATION PLAN**

STA 41+00 TO STA 43+00

SHEET 10 OF 16

DESIGN	CHECKED	DRAWN	PROJECT NO.	SUBMITTAL	SHEET NO.
RD/AM	RD/AM	TM/RD	23-03763	70%	346

**GENERAL PLAN NOTES**

- IRRIGATION PLANS ARE GENERALLY DIAGRAMMATIC AND INDICATIVE OF THE WORK TO BE INSTALLED. IT IS THE INTENT OF THIS DESIGN THAT ALL MAINLINE AND LATERAL PIPES, VALVES, ETC., AND OTHER IRRIGATION SYSTEM APPURTENANCES BE INSTALL IN LANDSCAPE AREAS WHEREVER POSSIBLE AND WITHIN THE PUBLIC RIGHT-OF-WAY.
- THE CONTRACTOR SHALL ROUTE ALL IRRIGATION MAINLINE AND LATERAL PIPE AND SLEEVES AROUND ALL SERVICE LINES, NEW AND EXISTING TREES, UTILITIES, STORM DRAINAGE FACILITIES, ETC., IN ORDER TO AVOID ANY CONFLICTS. INSTALL IRRIGATION PIPE BELOW STORM DRAINAGE PIPES WHERE REQUIRED AND INSTRUCTED.

**GENERAL PLAN LEGEND**

SLEEVING: INSTALL IN LOCATIONS AS SHOWN ON PLAN. REFER TO PIPE/WIRE SLEEVING CHART ON THIS SHEET FOR SIZE AND TYPE.

- (#) M = MAINLINE SLEEVE
- (#) L = LATERAL SLEEVE
- (#) W = WIRING CONDUIT
- LIMIT OF WORK

**VALVE CALL OUT**

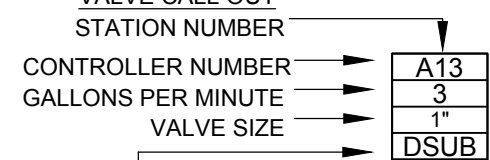

- DSUB - SUBSURFACE DRIP IRRIGATION
- TBUB - ROOT WATERING TREE BUBBLER
- TRNG - ROOT WATER TREE RING



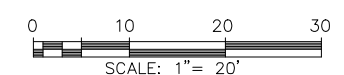
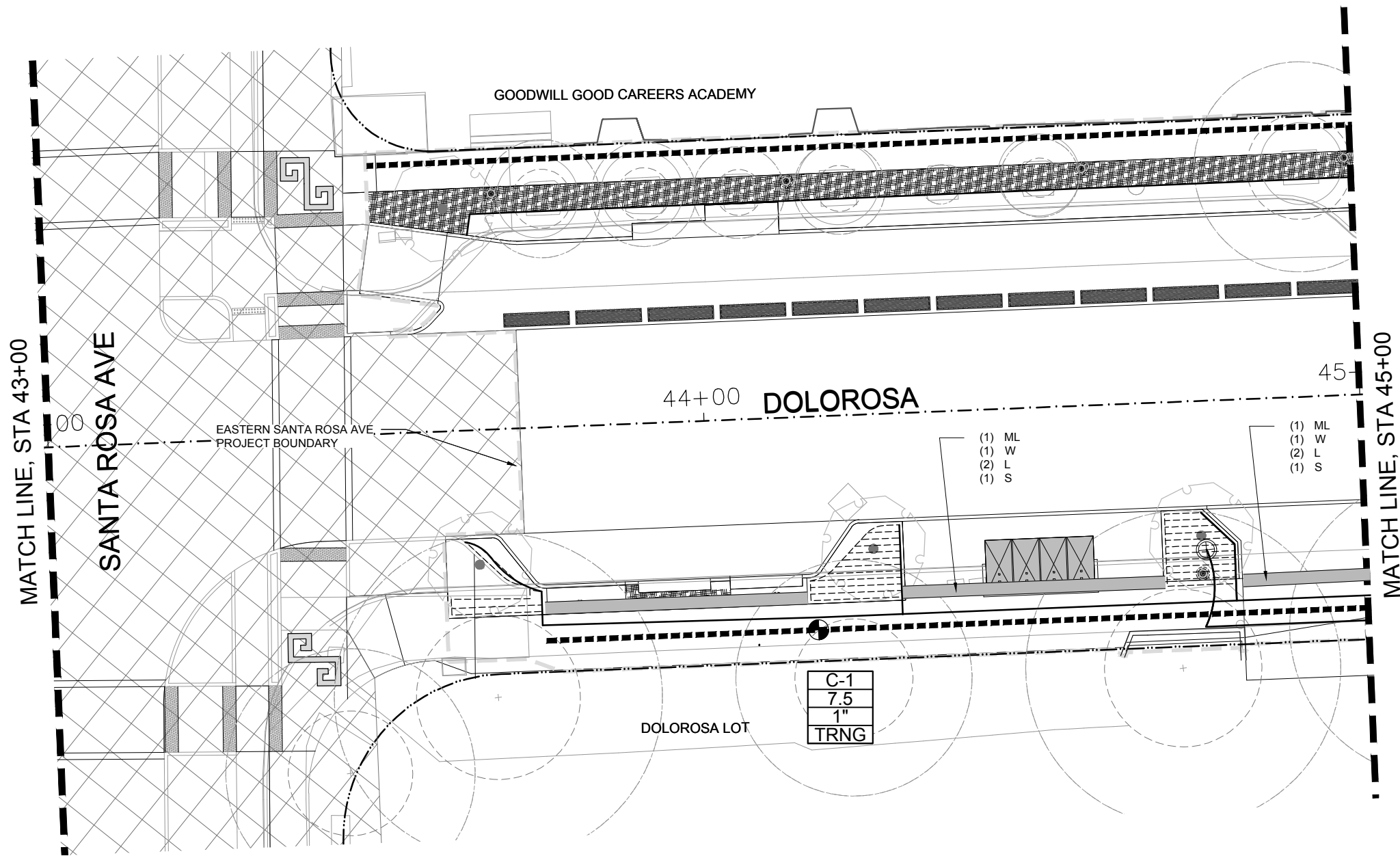

REV. NO.	DATE	DESCRIPTION	BY

**MOORE IACOFANO GOLTSMAN, INC.**  
 317 LEXINGTON AVENUE, SUITE 2 TEL 210-600-9990  
 SAN ANTONIO, TEXAS, CA 78215 www.migcom.com



SAN ANTONIO | AUSTIN | HOUSTON | FORT WORTH | DALLAS  
 3800 NW LOOP 416 | SAN ANTONIO, TX 78215 | 210.325.9999  
 TEXAS ENGINEERING FIRM #479 | TEXAS SURVEYING FIRM #10020000



CITY OF SAN ANTONIO  
**PUBLIC WORKS DEPARTMENT**

DOLOROSA  
 IRRIGATION PLAN

STA 43+00 TO STA 45+00

SHEET 11 OF 16

DESIGN	CHECKED	DRAWN	PROJECT NO.	SUBMITTAL	SHEET NO.
RD/AM	RD/AM	TM/RD	23-03763	70%	347

**GENERAL PLAN NOTES**

- IRRIGATION PLANS ARE GENERALLY DIAGRAMMATIC AND INDICATIVE OF THE WORK TO BE INSTALLED. IT IS THE INTENT OF THIS DESIGN THAT ALL MAINLINE AND LATERAL PIPES, VALVES, ETC., AND OTHER IRRIGATION SYSTEM APPURTENANCES BE INSTALL IN LANDSCAPE AREAS WHEREVER POSSIBLE AND WITHIN THE PUBLIC RIGHT-OF-WAY.
- THE CONTRACTOR SHALL ROUTE ALL IRRIGATION MAINLINE AND LATERAL PIPE AND SLEEVES AROUND ALL SERVICE LINES, NEW AND EXISTING TREES, UTILITIES, STORM DRAINAGE FACILITIES, ETC., IN ORDER TO AVOID ANY CONFLICTS. INSTALL IRRIGATION PIPE BELOW STORM DRAINAGE PIPES WHERE REQUIRED AND INSTRUCTED.

**GENERAL PLAN LEGEND**

SLEEVING: INSTALL IN LOCATIONS AS SHOWN ON PLAN. REFER TO PIPE/WIRE SLEEVING CHART ON THIS SHEET FOR SIZE AND TYPE.

- (#) M = MAINLINE SLEEVE
- (#) L = LATERAL SLEEVE
- (#) W = WIRING CONDUIT
- LIMIT OF WORK

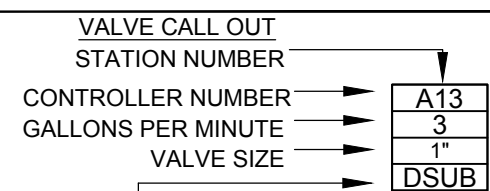

- DSUB - SUBSURFACE DRIP IRRIGATION
- TBUB - ROOT WATERING TREE BUBBLER
- TRNG - ROOT WATER TREE RING

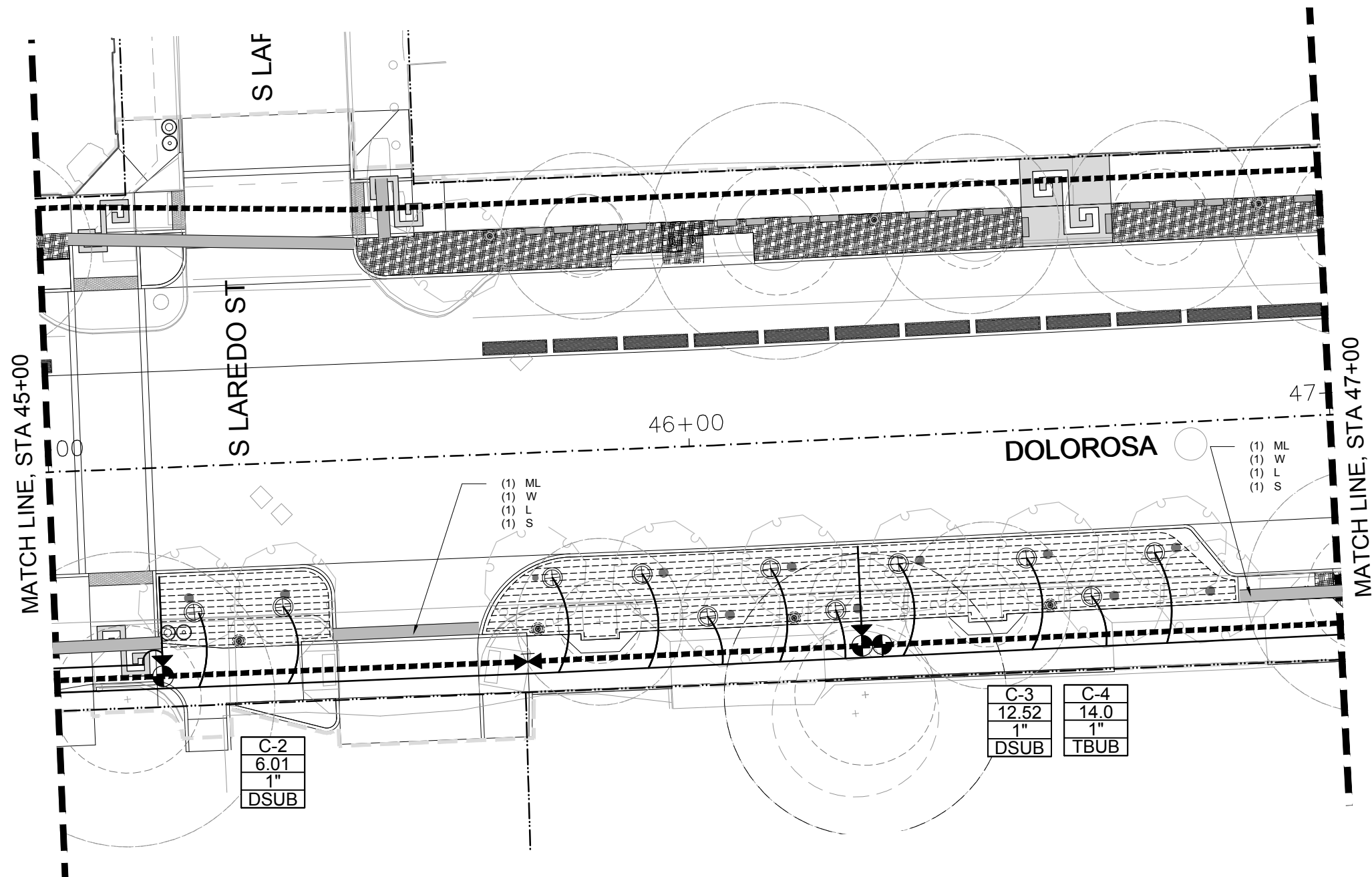

C-2
6.01
1"
DSUB

C-3	C-4
12.52	14.0
1"	1"
DSUB	TBUB

**GENERAL PLAN NOTES**

- IRRIGATION PLANS ARE GENERALLY DIAGRAMMATIC AND INDICATIVE OF THE WORK TO BE INSTALLED. IT IS THE INTENT OF THIS DESIGN THAT ALL MAINLINE AND LATERAL PIPES, VALVES, ETC., AND OTHER IRRIGATION SYSTEM APPURTENANCES BE INSTALL IN LANDSCAPE AREAS WHEREVER POSSIBLE AND WITHIN THE PUBLIC RIGHT-OF-WAY.
- THE CONTRACTOR SHALL ROUTE ALL IRRIGATION MAINLINE AND LATERAL PIPE AND SLEEVES AROUND ALL SERVICE LINES, NEW AND EXISTING TREES, UTILITIES, STORM DRAINAGE FACILITIES, ETC., IN ORDER TO AVOID ANY CONFLICTS. INSTALL IRRIGATION PIPE BELOW STORM DRAINAGE PIPES WHERE REQUIRED AND INSTRUCTED.

**GENERAL PLAN LEGEND**

SLEEVING: INSTALL IN LOCATIONS AS SHOWN ON PLAN. REFER TO PIPE/WIRE SLEEVING CHART ON THIS SHEET FOR SIZE AND TYPE.

- (#) M = MAINLINE SLEEVE
- (#) L = LATERAL SLEEVE
- (#) W = WIRING CONDUIT
- LIMIT OF WORK

**VALVE CALL OUT**

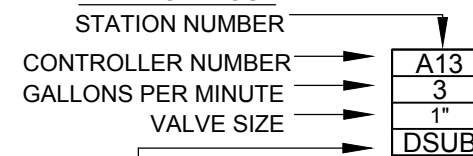

- DSUB - SUBSURFACE DRIP IRRIGATION
- TBUB - ROOT WATERING TREE BUBBLER
- TRNG - ROOT WATER TREE RING

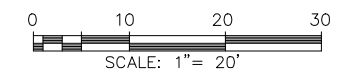

REV. NO.	DATE	DESCRIPTION	BY

**MOORE IACOFANO GOLTSMAN, INC.**  
 317 LEXINGTON AVENUE, SUITE 2  
 SAN ANTONIO, TEXAS, CA 78215  
 TEL 210-600-9990  
 www.migcom.com



SAN ANTONIO | AUSTIN | HOUSTON | FORT WORTH | DALLAS  
 3800 HWY 198P-418 | SAN ANTONIO, TX 78218 | 210.325.9999  
 TEXAS ENGINEERING FIRM #170 | TEXAS SURVEYING FIRM #10020000



**DOLOROSA**  
**IRRIGATION PLAN**

STA 45+00 TO STA 47+00

SHEET 12 OF 16

DESIGN	CHECKED	DRAWN	PROJECT NO.	SUBMITTAL	SHEET NO.
RD/AM	RD/AM	TM/RD	23-03763	70%	348

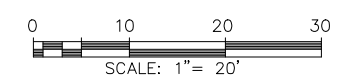
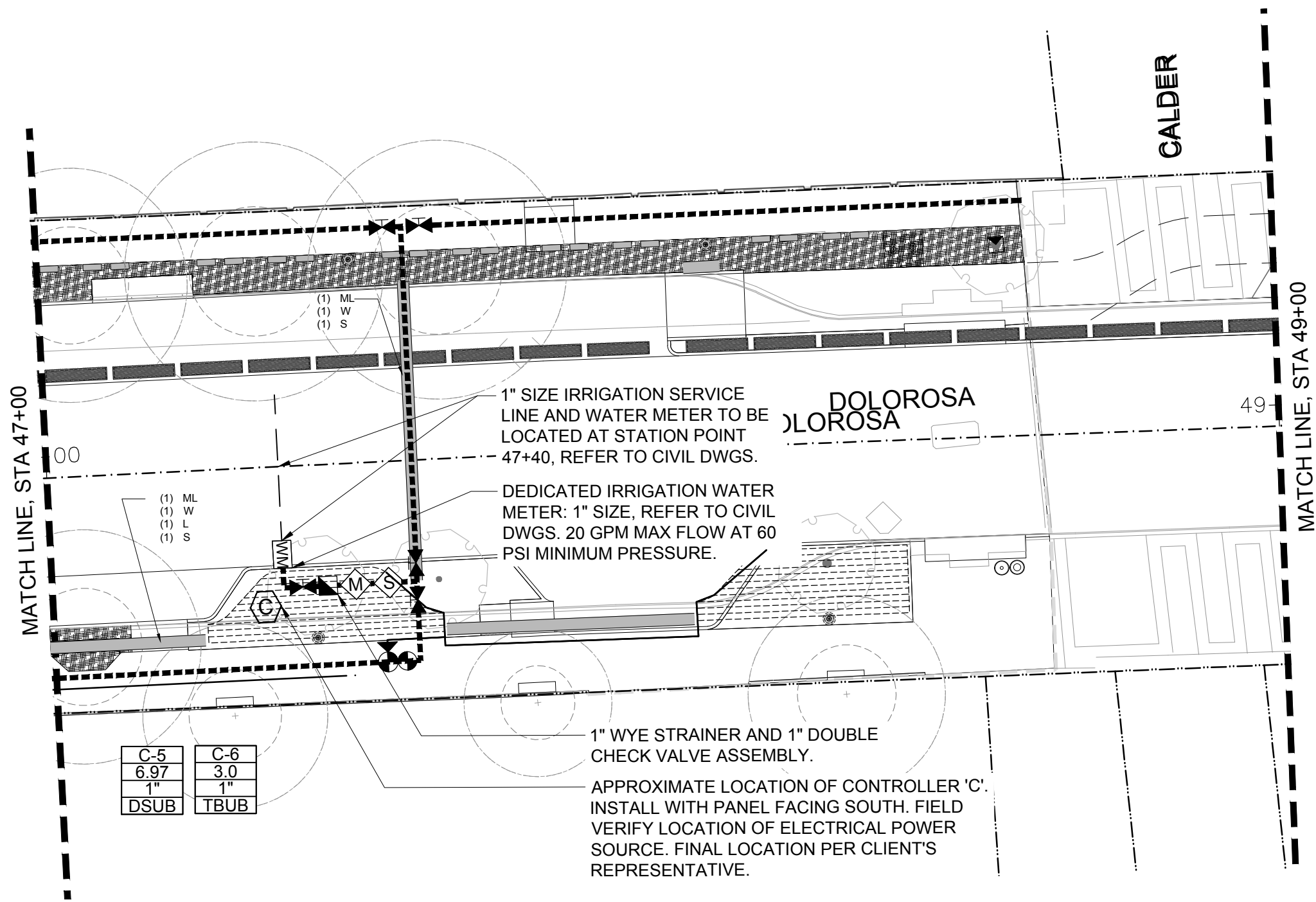

REV. NO.	DATE	DESCRIPTION	BY

**MIG** MOORE IACOFANO GOLTSMAN, INC.  
317 LEXINGTON AVENUE, SUITE 2  
SAN ANTONIO, TEXAS, CA 78215  
TEL 210-600-9990  
www.migcom.com



SAN ANTONIO | AUSTIN | HOUSTON | FORT WORTH | DALLAS  
3800 HWY 150P-418 | SAN ANTONIO, TX 78216 | 210.325.9999  
TEXAS ENGINEERING FIRM #470 | TEXAS SURVEYING FIRM #10000000



CITY OF SAN ANTONIO  
**PUBLIC WORKS DEPARTMENT**

DOLOROSA  
IRRIGATION PLAN

STA 47+00 TO STA 49+00

SHEET 13 OF 16

DESIGN	CHECKED	DRAWN	PROJECT NO.	SUBMITTAL	SHEET NO.
RD/AM	RD/AM	TM/RD	23-03763	70%	349

**GENERAL PLAN NOTES**

- IRRIGATION PLANS ARE GENERALLY DIAGRAMMATIC AND INDICATIVE OF THE WORK TO BE INSTALLED. IT IS THE INTENT OF THIS DESIGN THAT ALL MAINLINE AND LATERAL PIPES, VALVES, ETC., AND OTHER IRRIGATION SYSTEM APPURTENANCES BE INSTALL IN LANDSCAPE AREAS WHEREVER POSSIBLE AND WITHIN THE PUBLIC RIGHT-OF-WAY.
- THE CONTRACTOR SHALL ROUTE ALL IRRIGATION MAINLINE AND LATERAL PIPE AND SLEEVES AROUND ALL SERVICE LINES, NEW AND EXISTING TREES, UTILITIES, STORM DRAINAGE FACILITIES, ETC., IN ORDER TO AVOID ANY CONFLICTS. INSTALL IRRIGATION PIPE BELOW STORM DRAINAGE PIPES WHERE REQUIRED AND INSTRUCTED.

**GENERAL PLAN LEGEND**

SLEEVING: INSTALL IN LOCATIONS AS SHOWN ON PLAN. REFER TO PIPE/WIRE SLEEVING CHART ON THIS SHEET FOR SIZE AND TYPE.

(#) M = MAINLINE SLEEVE  
(#) L = LATERAL SLEEVE  
(#) W = WIRING CONDUIT  
- - - - - LIMIT OF WORK

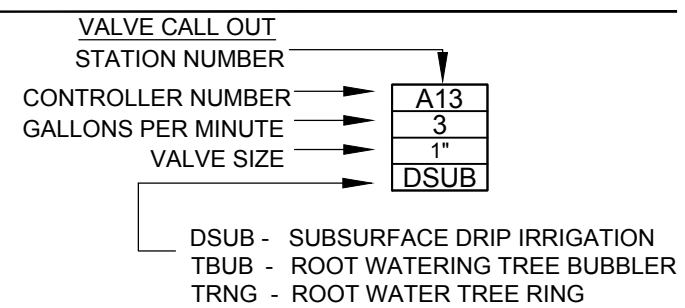

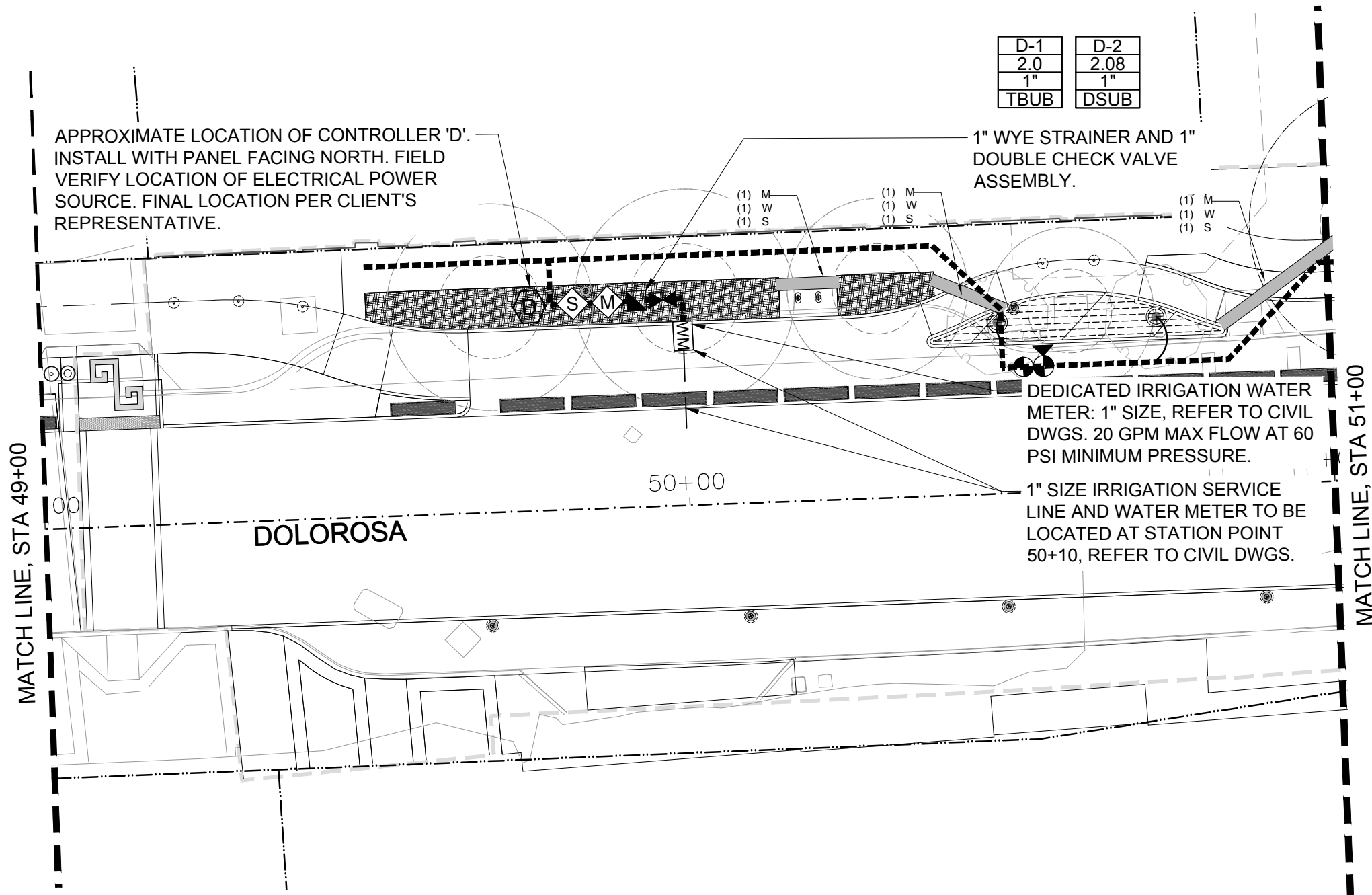

D-1	D-2
2.0	2.08
1"	1"
TBUB	DSUB

APPROXIMATE LOCATION OF CONTROLLER 'D'.  
INSTALL WITH PANEL FACING NORTH.  
FIELD VERIFY LOCATION OF ELECTRICAL POWER  
SOURCE. FINAL LOCATION PER CLIENT'S  
REPRESENTATIVE.

1" WYE STRAINER AND 1"  
DOUBLE CHECK VALVE  
ASSEMBLY.

DEDICATED IRRIGATION WATER  
METER: 1" SIZE, REFER TO CIVIL  
DWGS. 20 GPM MAX FLOW AT 60  
PSI MINIMUM PRESSURE.

1" SIZE IRRIGATION SERVICE  
LINE AND WATER METER TO BE  
LOCATED AT STATION POINT  
50+10, REFER TO CIVIL DWGS.

MATCH LINE, STA 49+00

MATCH LINE, STA 51+00

DOLOROSA

50+00

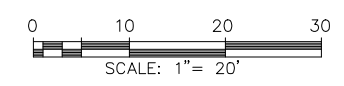

REV. NO.	DATE	DESCRIPTION	BY

**MIG** MOORE IACOFANO GOLTSMAN, INC.  
317 LEXINGTON AVENUE, SUITE 2  
SAN ANTONIO, TEXAS, CA 78215 TEL 210-600-9990  
www.migcom.com

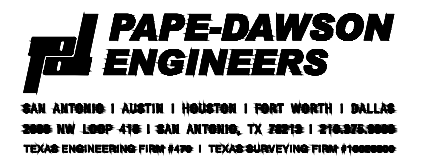

DOLOROSA  
IRRIGATION PLAN

STA 49+00 TO STA 51+00

SHEET 14 OF 16

DESIGN	CHECKED	DRAWN	PROJECT NO.	SUBMITTAL	SHEET NO.
RD/AM	RD/AM	TM/RD	23-03763	70%	350

**GENERAL PLAN NOTES**

- IRRIGATION PLANS ARE GENERALLY DIAGRAMMATIC AND INDICATIVE OF THE WORK TO BE INSTALLED. IT IS THE INTENT OF THIS DESIGN THAT ALL MAINLINE AND LATERAL PIPES, VALVES, ETC., AND OTHER IRRIGATION SYSTEM APPURTENANCES BE INSTALL IN LANDSCAPE AREAS WHEREVER POSSIBLE AND WITHIN THE PUBLIC RIGHT-OF-WAY.
- THE CONTRACTOR SHALL ROUTE ALL IRRIGATION MAINLINE AND LATERAL PIPE AND SLEEVES AROUND ALL SERVICE LINES, NEW AND EXISTING TREES, UTILITIES, STORM DRAINAGE FACILITIES, ETC., IN ORDER TO AVOID ANY CONFLICTS. INSTALL IRRIGATION PIPE BELOW STORM DRAINAGE PIPES WHERE REQUIRED AND INSTRUCTED.

**GENERAL PLAN LEGEND**

- SLEEVING: INSTALL IN LOCATIONS AS SHOWN ON PLAN. REFER TO PIPE/WIRE SLEEVING CHART ON THIS SHEET FOR SIZE AND TYPE.
- (#) M = MAINLINE SLEEVE
  - (#) L = LATERAL SLEEVE
  - (#) W = WIRING CONDUIT
  - — — — — LIMIT OF WORK

VALVE CALL OUT  
STATION NUMBER  
CONTROLLER NUMBER  
GALLONS PER MINUTE  
VALVE SIZE

A13
3
1"
DSUB

DSUB - SUBSURFACE DRIP IRRIGATION  
TBUB - ROOT WATERING TREE BUBBLER  
TRNG - ROOT WATER TREE RING

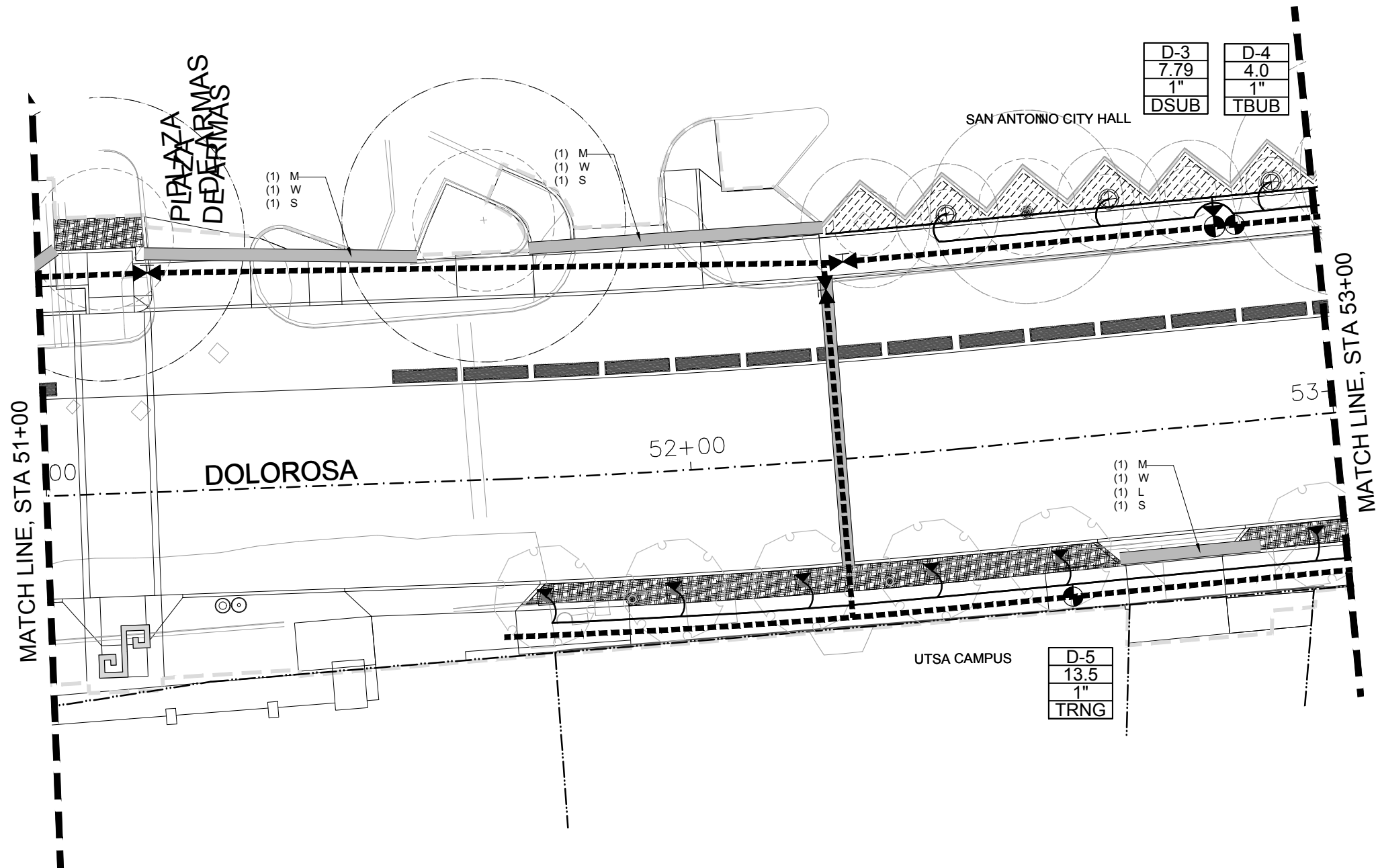

D-3	D-4
7.79	4.0
1"	1"
DSUB	TBUB

D-5
13.5
1"
TRNG

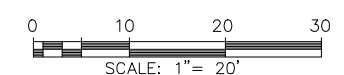

REV. NO.	DATE	DESCRIPTION	BY

**MOORE IACOFANO GOLTSMAN, INC.**  
317 LEXINGTON AVENUE, SUITE 2  
 SAN ANTONIO, TEXAS, CA 78215  
 TEL 210-600-9990  
 www.migcom.com



SAN ANTONIO | AUSTIN | HOUSTON | FORT WORTH | DALLAS  
 3800 HWY 190P-418 | SAN ANTONIO, TX 78216 | 210.325.9999  
 TEXAS ENGINEERING FIRM #479 | TEXAS SURVEYING FIRM #10020000



CITY OF SAN ANTONIO  
**PUBLIC WORKS DEPARTMENT**

DOLOROSA

IRRIGATION PLAN

STA 51+00 TO STA 53+00

SHEET 15 OF 16

DESIGN	CHECKED	DRAWN	PROJECT NO.	SUBMITTAL	SHEET NO.
RD/AM	RD/AM	TM/RD	23-03763	70%	351

**GENERAL PLAN NOTES**

- IRRIGATION PLANS ARE GENERALLY DIAGRAMMATIC AND INDICATIVE OF THE WORK TO BE INSTALLED. IT IS THE INTENT OF THIS DESIGN THAT ALL MAINLINE AND LATERAL PIPES, VALVES, ETC., AND OTHER IRRIGATION SYSTEM APPURTENANCES BE INSTALL IN LANDSCAPE AREAS WHEREVER POSSIBLE AND WITHIN THE PUBLIC RIGHT-OF-WAY.
- THE CONTRACTOR SHALL ROUTE ALL IRRIGATION MAINLINE AND LATERAL PIPE AND SLEEVES AROUND ALL SERVICE LINES, NEW AND EXISTING TREES, UTILITIES, STORM DRAINAGE FACILITIES, ETC., IN ORDER TO AVOID ANY CONFLICTS. INSTALL IRRIGATION PIPE BELOW STORM DRAINAGE PIPES WHERE REQUIRED AND INSTRUCTED.

**GENERAL PLAN LEGEND**

SLEEVING: INSTALL IN LOCATIONS AS SHOWN ON PLAN. REFER TO PIPE/WIRE SLEEVING CHART ON THIS SHEET FOR SIZE AND TYPE.

- (#) M = MAINLINE SLEEVE
- (#) L = LATERAL SLEEVE
- (#) W = WIRING CONDUIT
- — — — — LIMIT OF WORK

**VALVE CALL OUT**

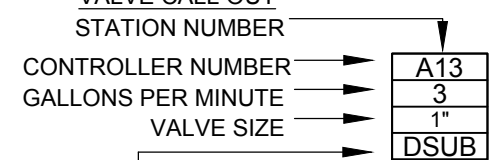

- DSUB - SUBSURFACE DRIP IRRIGATION
- TBUB - ROOT WATERING TREE BUBBLER
- TRNG - ROOT WATER TREE RING

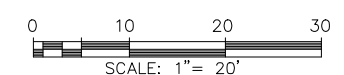
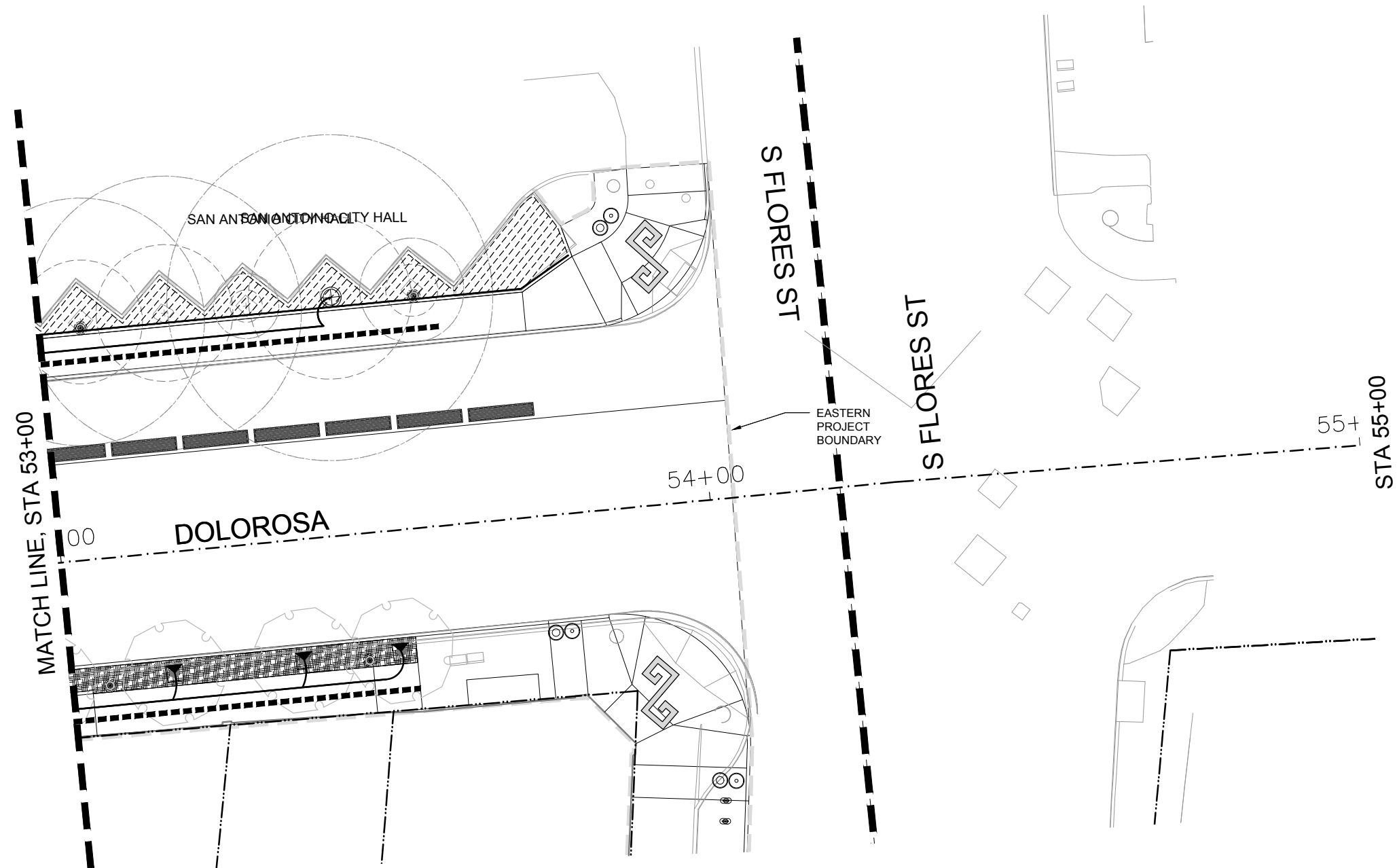

REV. NO.	DATE	DESCRIPTION	BY

**MOORE IACOFANO GOLTSMAN, INC.**  
 317 LEXINGTON AVENUE, SUITE 2  
 SAN ANTONIO, TEXAS, CA 78215  
 TEL 210-600-9990  
 www.migcom.com



SAN ANTONIO | AUSTIN | HOUSTON | FORT WORTH | DALLAS  
 3800 HWY 198P-418 | SAN ANTONIO, TX 78218 | 210.325.9999  
 TEXAS ENGINEERING FIRM #479 | TEXAS SURVEYING FIRM #10028899



CITY OF SAN ANTONIO  
**PUBLIC WORKS DEPARTMENT**

DOLOROSA

IRRIGATION PLAN

STA 53+00 TO STA 55+00

SHEET 16 OF 16

DESIGN	CHECKED	DRAWN	PROJECT NO.	SUBMITTAL	SHEET NO.
RD/AM	RD/AM	TM/RD	23-03763	70%	352

**GENERAL PLAN NOTES**

- IRRIGATION PLANS ARE GENERALLY DIAGRAMMATIC AND INDICATIVE OF THE WORK TO BE INSTALLED. IT IS THE INTENT OF THIS DESIGN THAT ALL MAINLINE AND LATERAL PIPES, VALVES, ETC., AND OTHER IRRIGATION SYSTEM APPURTENANCES BE INSTALL IN LANDSCAPE AREAS WHEREVER POSSIBLE AND WITHIN THE PUBLIC RIGHT-OF-WAY.
- THE CONTRACTOR SHALL ROUTE ALL IRRIGATION MAINLINE AND LATERAL PIPE AND SLEEVES AROUND ALL SERVICE LINES, NEW AND EXISTING TREES, UTILITIES, STORM DRAINAGE FACILITIES, ETC., IN ORDER TO AVOID ANY CONFLICTS. INSTALL IRRIGATION PIPE BELOW STORM DRAINAGE PIPES WHERE REQUIRED AND INSTRUCTED.

**GENERAL PLAN LEGEND**

SLEEVING: INSTALL IN LOCATIONS AS SHOWN ON PLAN. REFER TO PIPE/WIRE SLEEVING CHART ON THIS SHEET FOR SIZE AND TYPE.

- (#) M = MAINLINE SLEEVE
- (#) L = LATERAL SLEEVE
- (#) W = WIRING CONDUIT
- — — — — LIMIT OF WORK

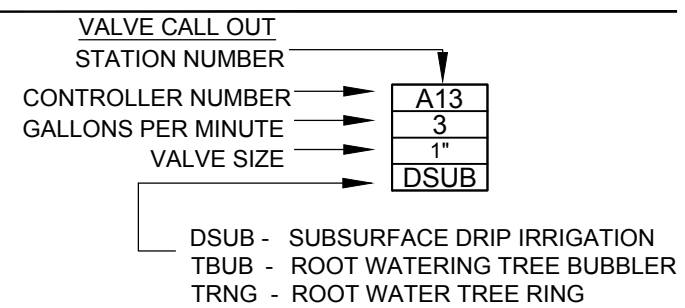

DEPTH	A	B	C	D	E	F
4" AND LARGER	N/A	30"	N/A	1"	4"	2"
3" AND SMALLER	24"	24"	N/A	1"	4"	2"
2-1/2" AND SMALLER	24"	24"	N/A	1"	4"	2"
CONTROL WIRES	N/A	N/A	24"	1"	4"	2"

- NOTES:**
- DIG SIDES OF TRENCH SQUARE AND CLEAN OF ALL SHARP MATERIAL.
  - NON-PRESSURE PIPES RUNNING PARALLEL TO EACH OTHER MUST HAVE A MIN. CLEARANCE OF 6" FROM EACH OTHER.
  - IRRIGATION PIPES SHALL HAVE A MIN. CLEARANCE OF 24" FROM OTHER TRADES.
  - PROVIDE A 24" LOOP IN ALL WIRING AT CHANGES IN DIRECTION.
  - CONTRACTOR MUST ADJUST MAINLINE AS REQUIRED TO AVOID OTHER ELEMENTS.
  - ALL SLEEVES MUST BE A MIN. OF 2 TIMES THE DIAMETER OF THE PIPE WITHIN
  - ALL SLEEVES MUST EXTEND 12" MIN. DISTANCE PAST CURB OR PAVEMENT EDGES.

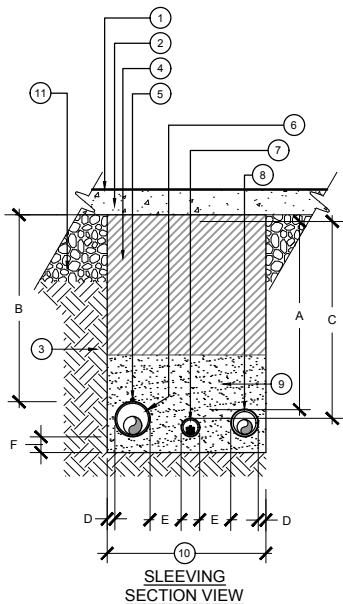

- FINISH GRADE
- VEHICULAR OR PEDESTRIAN PAVING
- UNDISTURBED SOIL
- COMPACTED BACKFILL OVER INITIAL SAND BEDDING:  
- BENEATH VEHICULAR PAVEMENT SHALL BE COMPACTED CLASS II AGG., DEPTH AND COMPACTION PER ENGINEER'S PLANS  
- BENEATH NON-VEHICULAR PAVEMENT SHALL BE NATIVE SITE SOIL, NO PARTICLES GREATER THAN 1". COMPACT PER SPECS.
- COPPER TRACE WIRE, REFER TO SPECS.
- PRESSURE MAINLINE PIPE SLEEVE, PER SPECS.
- CONTROL WIRE SLEEVE, PER SPECS
- NON-PRESSURE LATERAL LINE SLEEVE, SEE SPECS.
- INITIAL SAND BACKFILL PER SPECS. PROVIDE 6" BEDDING DEPTH BELOW MAINLINE AND 6" COVER ABOVE MAINLINE. COMPACT PER SPECS.
- 9" MIN. OR AS NEEDED TO PROVIDE FOR A MINIMUM 6" CLEARANCE BETWEEN PIPES.
- PAVEMENT SUBGRADE - AS PER ENGINEER'S PLANS

DEPTH	A	B	C	D	E	F
4" AND LARGER	N/A	24"	N/A	1"	6"	2"
3" AND SMALLER	12"	18"	N/A	1"	6"	2"
2-1/2" AND SMALLER	12"	18"	N/A	1"	6"	2"
CONTROL WIRES	N/A	N/A	BELOW MAINLINE	1"	6"	2"

- NOTES:**
- DIG SIDES OF TRENCH SQUARE AND CLEAN OF ALL SHARP MATERIAL.
  - NON-PRESSURE PIPES RUNNING PARALLEL TO EACH OTHER MUST HAVE A MIN. CLEARANCE OF 6" FROM EACH OTHER.
  - IRRIGATION PIPES SHALL HAVE A MIN. CLEARANCE OF 24" FROM OTHER TRADES.
  - PROVIDE A 24" LOOP IN ALL WIRING AT CHANGES IN DIRECTION.
  - CONTRACTOR MUST ADJUST MAINLINE AS REQUIRED TO AVOID OTHER ELEMENTS.

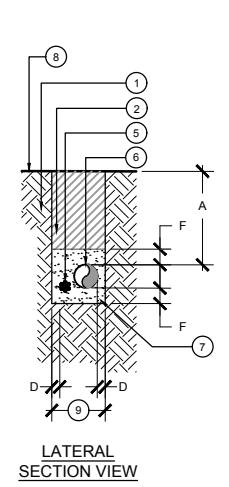
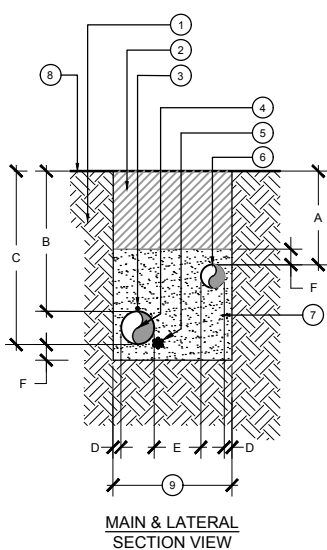

- UNDISTURBED SOIL
- COMPACTED BACKFILL OVER INITIAL SAND BEDDING. NO PARTICLES GREATER THAN 1". COMPACT PER SPECS.
- COPPER TRACE WIRE. REFER TO SPECS.
- PRESSURE MAINLINE PIPE, PER SPECS.
- CONTROL WIRES, BUNDLED AND TAPED TO SIDE OF MAINLINE AT 10' O.C. (INSTALL WIRES IN CONDUIT FROM CONTROLLER TO MAINLINE).
- NON-PRESSURE LATERAL LINE, PER SPECS.
- INITIAL SAND BACKFILL PER SPECS. PROVIDE BEDDING DEPTH BELOW MAINLINE AND COVER ABOVE MAINLINE/LATERAL PER CHART. COMPACT PER SPECS.
- FINISH GRADE
- 9" MIN. OR AS NEEDED TO PROVIDE FOR A MINIMUM 6" CLEARANCE BETWEEN PIPES.

## 2 SLEEVE DETAIL

Scale: N.T.S.

- NOTES:**
- INSTALL VALVE BOXES IN GROUND COVER/ SHRUB PLANTING AREAS WHENEVER POSSIBLE.
  - ALL VALVE BOXES MUST BE PERPENDICULAR TO EDGE OF AREA, ADJACENT PAVING OR CONCRETE CURB AND SET PARALLEL TO EACH OTHER.
  - ALL VALVES MUST BE CENTERED AND INSTALLED PLUMB INSIDE VALVE BOX TO FACILITATE ACCESS AND MAINTENANCE.
  - ALL VALVES MUST BE INSTALLED IN ITS OWN VALVE BOX.
  - REFER TO VALVE ASSEMBLY DETAILS FOR VALVE BOXES FINISH ELEVATIONS.
  - AVOID EXCESSIVE COMPACTING AROUND VALVE BOXES TO PREVENT COLLAPSE AND DEFORMATION OF VALVE BOX SIDES.
  - INSTALL VALVE BOX EXTENSIONS BY VALVE MANUFACTURER AS REQUIRED TO COMPLETELY ENCLOSE VALVE ASSEMBLY.
  - LOCATION OF VALVE ASSEMBLIES SHALL BE STAKED FOR APPROVAL BY OWNER'S REPRESENTATIVE PRIOR TO INSTALLATION.
  - ALL VALVE BOX LIDS MUST BE LABELED BY HOT IRON BRANDING:  
YS - WYE STRAINER  
CV - CHECK VALVE  
MV - MASTER VALVE  
FS - FLOW SENSOR  
RCV - REMOTE CONTROL VALVE  
QCV - QUICK COUPLER VALVE  
BV - ISOLATION BALL VALVE  
GV - ISOLATION GATE VALVE  
E - PULL BOX/ SPLICE BOX

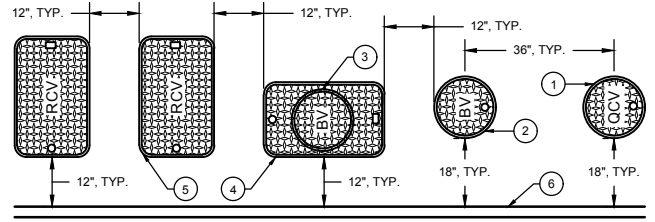

- 10" ROUND VALVE BOX PER SPECS FOR QUICK COUPLER VALVE, TYP.
- 10" ROUND VALVE BOX PER SPECS FOR QUICK COUPLER ISOLATION BALL VALVE, TYP.
- 10" ROUND VALVE BOX PER SPECS FOR MAINLINE ISOLATION GATE VALVE, TYP.
- RECTANGULAR VALVE BOX PER SPECS FOR MAINLINE ISOLATION BALL VALVE, TYP.
- RECTANGULAR VALVE BOX PER SPECS FOR REMOTE CONTROL VALVE ASSEMBLIES, TYP.
- EDGE OF AREA, SIDEWALK, CONCRETE CURB, ETC., TYP.

## 4 VALVE BOX LAYOUT

Scale: N.T.S.

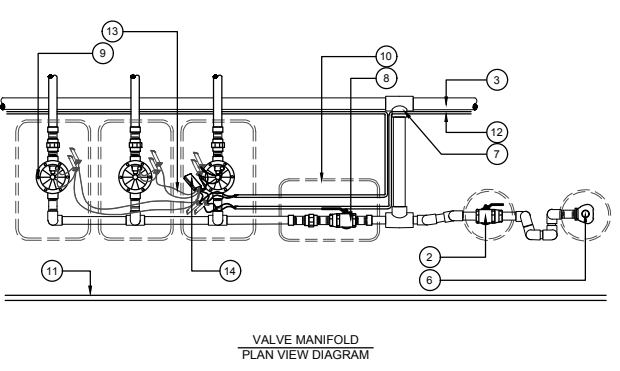
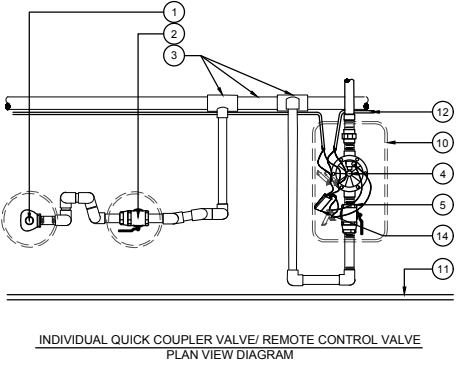

- INDIVIDUAL QUICK COUPLER VALVE WHEN VALVE IS NOT GROUPED WITHIN MAINLINE MANIFOLD ASSEMBLY.
- ISOLATION BALL VALVE
- PRESSURE MAINLINE AND TEE FITTING(S)
- INDIVIDUAL REMOTE CONTROL VALVE WITH BALL VALVE WHEN MANIFOLD IS NOT USED
- ISOLATION BALL VALVE WHEN SINGLE REMOTE CONTROL VALVE IS NOT GROUPED WITHIN MAINLINE MANIFOLD ASSEMBLY.
- QUICK COUPLER VALVE
- TEE. MUST BE MAINLINE SIZE.
- ISOLATION GATE VALVE OR BALL VALVE. VALVE MUST BE MAINLINE SIZE.
- MANIFOLD VALVES TOGETHER WHEN WITHIN 20 FEET OF EACH OTHER.
- VALVE BOX, TYP.
- EDGE OF AREA, ADJACENT PAVING OR CONCRETE CURB
- 2-WIRE DECODER CABLE
- 2-WIRE DECODER CABLE TO OTHER RCV/DECODERS
- DECODERS

- NOTES:**
- ALL THREADED CONNECTIONS MUST HAVE TEFLON TAPE (PVC/ BRASS) OR PASTE (BRASS ONLY).
  - REMOTE CONTROL VALVES SHALL BE INSTALLED WITH THE LARGEST VALVE AND GPM FLOW INSTALLED FIRST ON THE MANIFOLD, WITH THE SMALLER VALVES AND CAPACITIES TRANSITIONING FROM THERE.
  - REFER TO DETAIL #/L#.#.# FOR ALL ISOLATION BALL VALVE REQUIREMENTS.
  - REFER TO DETAIL #/L#.#.# FOR QUICK COUPLER VALVE REQUIREMENTS.
  - REFER TO DETAIL #/L#.#.#, 7/L2.5.2 FOR REMOTE CONTROL VALVE REQUIREMENTS.
  - REFER TO DETAIL #/L#.#.# FOR VALVE BOX LAYOUT REQUIREMENTS.
  - REFER TO DETAIL #/L#.#.# FOR PRESSURE MAINLINE AND NON-PRESSURE LATERALS PIPE REQUIREMENTS.

## 6 MANIFOLD INSTALLATION

Scale: N.T.S.

## 1 TYPICAL TRENCHING DETAIL

Scale: N.T.S.

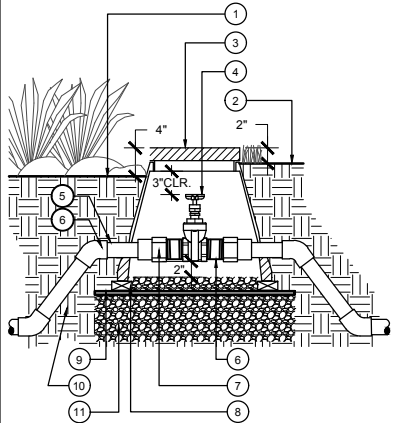

- FINISH GRADE AT PLANTER
- FINISH GRADE AT TURF AREA
- 10" ROUND VALVE BOX W/ BOLT DOWN COVER, AND SS HARDWARE
- ISOLATION GATE VALVE PER LEGEND AND SPECS.
- PVC MAINLINE PER LEGEND AND SPECS. USE PVC SCH. 80 45° ELL TO DEPTH PER SPECS.
- BRASS NIPPLE, 2 QTY., TYP
- PVC SCH. 80 MALE ADAPTERS, 2 QTY.
- CONCRETE BRICK SUPPORTS, THREE (3) SPACED EQUALLY ALONG PERIMETER BOTTOM.
- LANDSCAPE FABRIC AND 1/4" GALV. WIRE MESH, TYP.
- NATIVE SOIL COMPACTED TO 95% R.C.
- 3/8" PEA GRAVEL; 6" MINIMUM DEPTH BELOW VALVE BOX. EXTEND 6" BEYOND VALVE BOX WALL

- NOTES:**
- BALL VALVE MUST BE INSTALLED IN VALVE BOX TO ALLOW PROPER OPERATION OF BALL VALVE HANDLE.
  - ALL THREADED FITTINGS MUST HAVE 3/4" TEFLON TAPE OR PASTE.
  - PROVIDE 45° ELLS TO ACHIEVE BALL VALVE HEIGHT PER DETAIL.
  - WHEN MAINLINE IS TERMINATED AT THE VALVE, EXTEND MAINLINE 48" BEYOND VALVE AND CAP.

## 3 ISOLATION GATE VALVE (3" & SMALLER)

N.T.S.

REV. NO.	DATE	DESCRIPTION	BY

MOORE IACOFANO GOLTSMAN, INC.  
317 LEXINGTON AVENUE, SUITE 2  
SAN ANTONIO, TEXAS, CA 78215  
TEL 210-600-9990  
www.migcom.com

**PAPE-DAWSON ENGINEERS**  
SAN ANTONIO | AUSTIN | HOUSTON | FORT WORTH | DALLAS  
3800 HWY 198P-418 | SAN ANTONIO, TX 78213 | 210.325.9999  
TEXAS ENGINEERING FIRM #479 | TEXAS SURVEYING FIRM #10088999

CITY OF SAN ANTONIO  
PUBLIC WORKS DEPARTMENT

DOLOROSA

LANDSCAPE IRRIGATION  
DETAILS

SHEET 1 OF 5

DESIGN	CHECKED	DRAWN	PROJECT NO.	SUBMITTAL	SHEET NO.
RD/AM	RD/AM	TM/RD	23-03763	70%	353

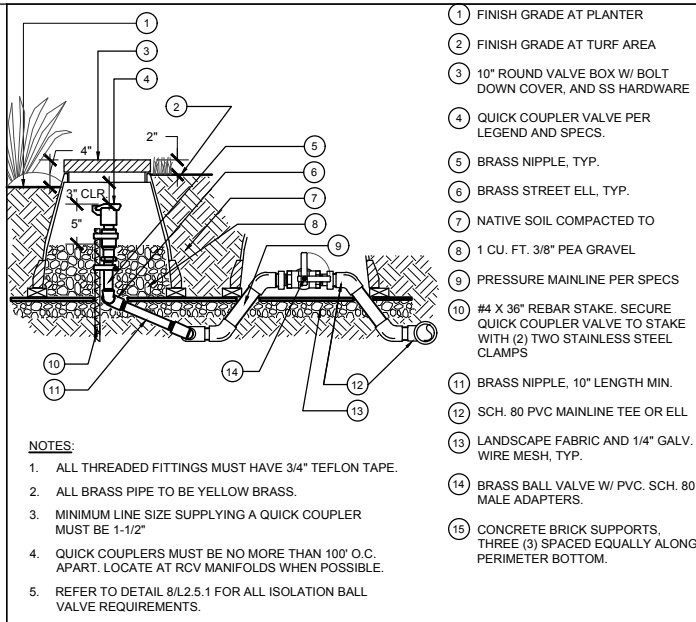

- 1 FINISH GRADE AT PLANTER
- 2 FINISH GRADE AT TURF AREA
- 3 10" ROUND VALVE BOX W/ BOLT DOWN COVER, AND SS HARDWARE
- 4 QUICK COUPLER VALVE PER LEGEND AND SPECS.
- 5 BRASS NIPPLE, TYP.
- 6 BRASS STREET ELL, TYP.
- 7 NATIVE SOIL COMPACTED TO
- 8 1 CU. FT. 3/8" PEA GRAVEL
- 9 PRESSURE MAINLINE PER SPECS
- 10 #4 X 36" REBAR STAKE. SECURE QUICK COUPLER VALVE TO STAKE WITH (2) TWO STAINLESS STEEL CLAMPS
- 11 BRASS NIPPLE, 10" LENGTH MIN.
- 12 SCH. 80 PVC MAINLINE TEE OR ELL
- 13 LANDSCAPE FABRIC AND 1/4" GALV. WIRE MESH, TYP.
- 14 BRASS BALL VALVE W/ PVC. SCH. 80 MALE ADAPTERS.
- 15 CONCRETE BRICK SUPPORTS, THREE (3) SPACED EQUALLY ALONG PERIMETER BOTTOM.

**NOTES:**

- ALL THREADED FITTINGS MUST HAVE 3/4" TEFLON TAPE.
- ALL BRASS PIPE TO BE YELLOW BRASS.
- MINIMUM LINE SIZE SUPPLYING A QUICK COUPLER MUST BE 1-1/2"
- QUICK COUPLERS MUST BE NO MORE THAN 100' O.C. APART. LOCATE AT RCV MANIFOLDS WHEN POSSIBLE.
- REFER TO DETAIL 8/L2.5.1 FOR ALL ISOLATION BALL VALVE REQUIREMENTS.

**3 QUICK COUPLER VALVE** Scale: N.T.S.

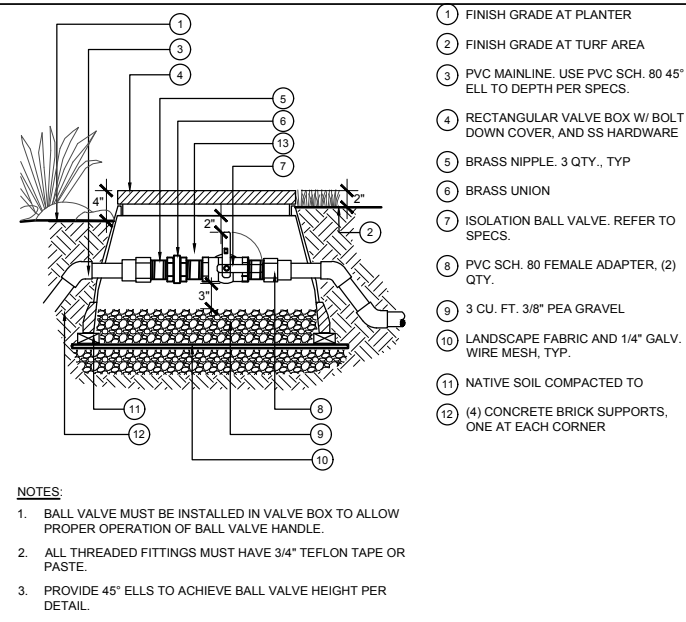

- 1 FINISH GRADE AT PLANTER
- 2 FINISH GRADE AT TURF AREA
- 3 PVC MAINLINE. USE PVC SCH. 80 45° ELL TO DEPTH PER SPECS.
- 4 RECTANGULAR VALVE BOX W/ BOLT DOWN COVER, AND SS HARDWARE
- 5 BRASS NIPPLE, 3 QTY., TYP
- 6 BRASS UNION
- 7 ISOLATION BALL VALVE. REFER TO SPECS.
- 8 PVC SCH. 80 FEMALE ADAPTER, (2) QTY.
- 9 3 CU. FT. 3/8" PEA GRAVEL
- 10 LANDSCAPE FABRIC AND 1/4" GALV. WIRE MESH, TYP.
- 11 NATIVE SOIL COMPACTED TO
- 12 (4) CONCRETE BRICK SUPPORTS, ONE AT EACH CORNER

**NOTES:**

- BALL VALVE MUST BE INSTALLED IN VALVE BOX TO ALLOW PROPER OPERATION OF BALL VALVE HANDLE.
- ALL THREADED FITTINGS MUST HAVE 3/4" TEFLON TAPE OR PASTE.
- PROVIDE 45° ELLS TO ACHIEVE BALL VALVE HEIGHT PER DETAIL.

**2 ISOLATION BALL VALVE** Scale: N.T.S.

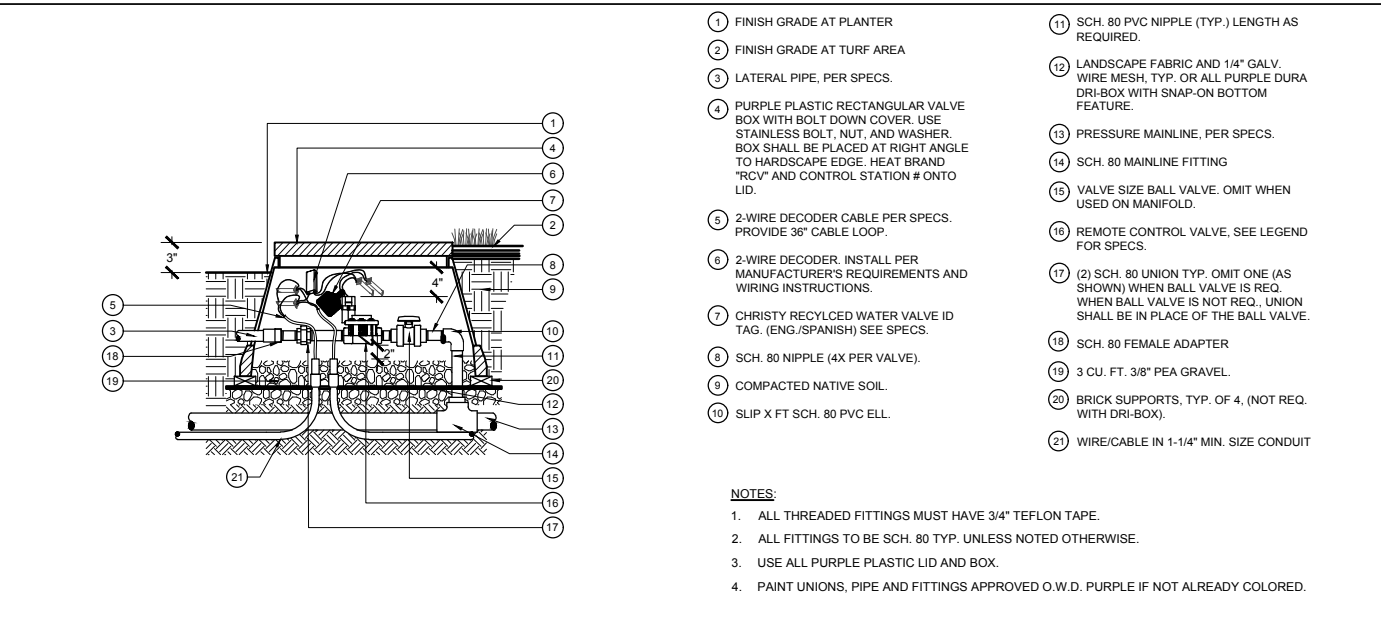

- 1 FINISH GRADE AT PLANTER
- 2 FINISH GRADE AT TURF AREA
- 3 LATERAL PIPE, PER SPECS.
- 4 PURPLE PLASTIC RECTANGULAR VALVE BOX WITH BOLT DOWN COVER. USE STAINLESS BOLT, NUT, AND WASHER. BOX SHALL BE PLACED AT RIGHT ANGLE TO HARDSCAPE EDGE. HEAT BRAND "RCV" AND CONTROL STATION # ONTO LID.
- 5 2-WIRE DECODER CABLE PER SPECS. PROVIDE 36" CABLE LOOP.
- 6 2-WIRE DECODER. INSTALL PER MANUFACTURER'S REQUIREMENTS AND WIRING INSTRUCTIONS.
- 7 CHRISTY RECYCLED WATER VALVE ID TAG. (ENG./SPANISH) SEE SPECS.
- 8 SCH. 80 NIPPLE (4X PER VALVE).
- 9 COMPACTED NATIVE SOIL.
- 10 SLIP X FT SCH. 80 PVC ELL.
- 11 SCH. 80 PVC NIPPLE (TYP.) LENGTH AS REQUIRED.
- 12 LANDSCAPE FABRIC AND 1/4" GALV. WIRE MESH, TYP. OR ALL PURPLE DURA DRI-BOX WITH SNAP-ON BOTTOM FEATURE.
- 13 PRESSURE MAINLINE, PER SPECS.
- 14 SCH. 80 MAINLINE FITTING
- 15 VALVE SIZE BALL VALVE. OMIT WHEN USED ON MANIFOLD.
- 16 REMOTE CONTROL VALVE, SEE LEGEND FOR SPECS.
- 17 (2) SCH. 80 UNION TYP. OMIT ONE (AS SHOWN) WHEN BALL VALVE IS REQ. WHEN BALL VALVE IS NOT REQ. UNION SHALL BE IN PLACE OF THE BALL VALVE.
- 18 SCH. 80 FEMALE ADAPTER
- 19 3 CU. FT. 3/8" PEA GRAVEL.
- 20 BRICK SUPPORTS, TYP. OF 4, (NOT REQ. WITH DRI-BOX).
- 21 WIRE/CABLE IN 1-1/4" MIN. SIZE CONDUIT

**NOTES:**

- ALL THREADED FITTINGS MUST HAVE 3/4" TEFLON TAPE.
- ALL FITTINGS TO BE SCH. 80 TYP. UNLESS NOTED OTHERWISE.
- USE ALL PURPLE PLASTIC LID AND BOX.
- PAINT UNIONS, PIPE AND FITTINGS APPROVED O.W.D. PURPLE IF NOT ALREADY COLORED.

**1 REMOTE CONTROL VALVE** Scale: N.T.S.

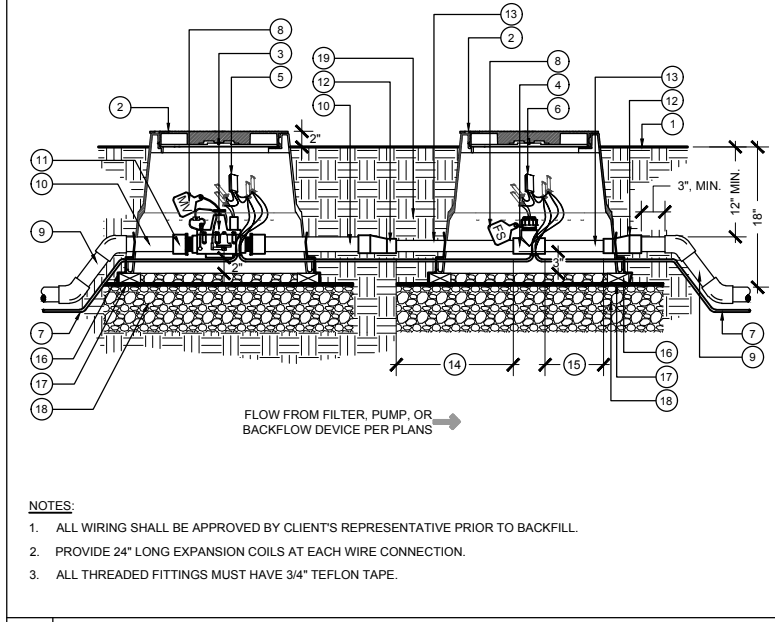

- 1 FINISH GRADE.
- 2 15"x20"x18" DEPTH RECTANGULAR VALVE BOX W/ BOLT DOWN COVER, AND STAINLESS STEEL HARDWARE. HEAT BRAND LIDS, "MV" AT MASTER VALVE AND "FS" AT FLOW SENSOR
- 3 MASTER VALVE PER LEGEND AND SPECS.
- 4 FLOW SENSOR WITH RECEPTACLE TEE FITTING PER LEGEND AND SPECS.
- 5 2-WIRE DECODER (SINGLE STATION), PER DETAIL ## AND SPECS.
- 6 2-WIRE SENSOR DECODER, PER DETAIL ## AND SPECS
- 7 2-WIRE JACKET CABLE PATH, TYP. PER LEGEND AND SPECS.
- 8 VALVE/SENSOR ID TAG. SEE SPECS.
- 9 PVC MAINLINE PER LEGEND AND SPECS. USE PVC SCH. 80 45° ELL AND NIPPLES TO DEPTH PER SPECS.
- 10 PVC SCH. 80 NIPPLE. LENGTH AS REQ. MAINLINE SIZE
- 11 PVC SCH. 80 MALE ADAPTER, 2 QTY. MAINLINE SIZE
- 12 PVC SCH. 80 ECCENTRIC REDUCER COUPLING (IF REQUIRED)
- 13 PVC. SCH. 80 NIPPLE. FLOW METER SIZE. LENGTH AS REQUIRED. 2 QTY.
- 14 MINIMUM UPSTREAM DISTANCE 10-TIMES FLOW METER SIZE
- 15 MINIMUM DOWNSTREAM DISTANCE 5-TIMES FLOW METER SIZE
- 16 (4) CONCRETE BRICK SUPPORTS, ONE AT EACH CORNER BOTTOM
- 17 LANDSCAPE FABRIC AND 1/4" GALV. WIRE MESH, TYP. WRAP FABRIC TO COVER PIPE PENETRATIONS AND PREVENT BACKFILL FROM ENTERING THE VALVE BOX.
- 18 3/8" PEA GRAVEL. 6" MINIMUM DEPTH BELOW VALVE BOX. EXTEND 6" BEYOND VALVE BOX WALL
- 19 NATIVE SOIL COMPACTED TO ORIGINAL DENSITY OR BETTER

**NOTES:**

- ALL WIRING SHALL BE APPROVED BY CLIENT'S REPRESENTATIVE PRIOR TO BACKFILL.
- PROVIDE 24" LONG EXPANSION COILS AT EACH WIRE CONNECTION.
- ALL THREADED FITTINGS MUST HAVE 3/4" TEFLON TAPE.

**5 MASTER CONTROL VALVE AND FLOW SENSOR (2-WIRE)** N.T.S.

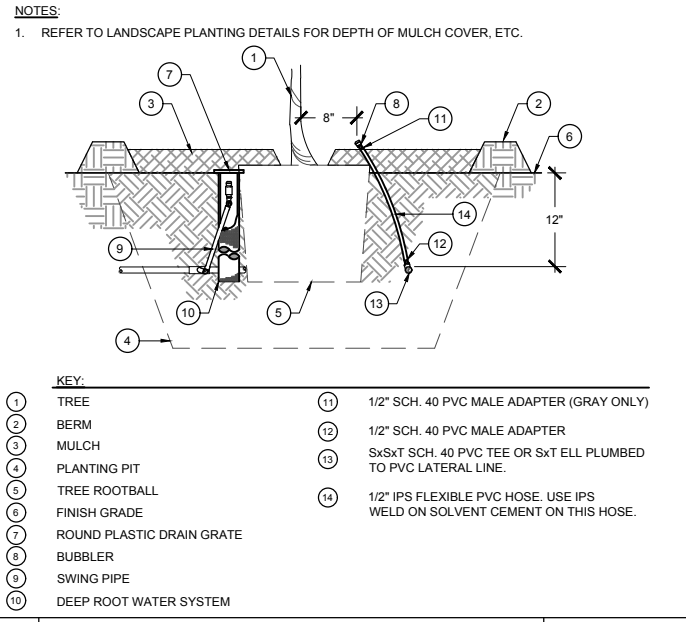

- 1 TREE
- 2 BERM
- 3 MULCH
- 4 PLANTING PIT
- 5 TREE ROOTBALL
- 6 FINISH GRADE
- 7 ROUND PLASTIC DRAIN GRATE
- 8 BUBBLER
- 9 SWING PIPE
- 10 DEEP ROOT WATER SYSTEM
- 11 1/2" SCH. 40 PVC MALE ADAPTER (GRAY ONLY)
- 12 1/2" SCH. 40 PVC MALE ADAPTER
- 13 5x5xT SCH. 40 PVC TEE OR SXT ELL PLUMBED TO PVC LATERAL LINE.
- 14 1/2" IPS FLEXIBLE PVC HOSE. USE IPS WELD ON SOLVENT CEMENT ON THIS HOSE.

**NOTES:**

- REFER TO LANDSCAPE PLANTING DETAILS FOR DEPTH OF MULCH COVER, ETC.

**4 TREE BUBBLER ASSEMBLY** Scale: N.T.S.

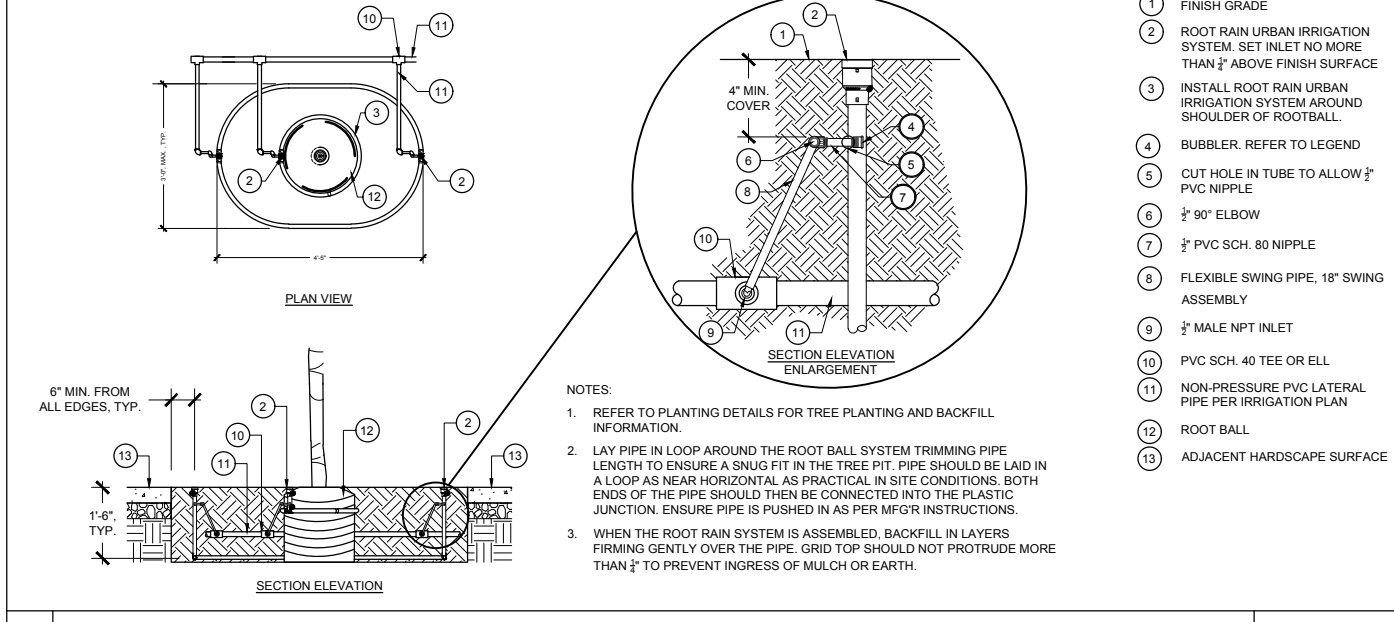

- 1 FINISH GRADE
- 2 ROOT RAIN URBAN IRRIGATION SYSTEM. SET INLET NO MORE THAN 1/2" ABOVE FINISH SURFACE
- 3 INSTALL ROOT RAIN URBAN IRRIGATION SYSTEM AROUND SHOULDER OF ROOTBALL.
- 4 BUBBLER. REFER TO LEGEND
- 5 CUT HOLE IN TUBE TO ALLOW 1/2" PVC NIPPLE
- 6 1/2" 90° ELBOW
- 7 1/2" PVC SCH. 80 NIPPLE
- 8 FLEXIBLE SWING PIPE, 18" SWING ASSEMBLY
- 9 1/2" MALE NPT INLET
- 10 PVC SCH. 40 TEE OR ELL
- 11 NON-PRESSURE PVC LATERAL PIPE PER IRRIGATION PLAN
- 12 ROOT BALL
- 13 ADJACENT HARDSCAPE SURFACE

**NOTES:**

- REFER TO PLANTING DETAILS FOR TREE PLANTING AND BACKFILL INFORMATION.
- LAY PIPE IN LOOP AROUND THE ROOT BALL SYSTEM TRIMMING PIPE LENGTH TO ENSURE A SNUG FIT IN THE TREE PIT. PIPE SHOULD BE LAID IN A LOOP AS NEAR HORIZONTAL AS PRACTICAL IN SITE CONDITIONS. BOTH ENDS OF THE PIPE SHOULD THEN BE CONNECTED INTO THE PLASTIC JUNCTION. ENSURE PIPE IS PUSHED IN AS PER MFG'R INSTRUCTIONS.
- WHEN THE ROOT RAIN SYSTEM IS ASSEMBLED, BACKFILL IN LAYERS FIRING GENTLY OVER THE PIPE. GRID TOP SHOULD NOT PROTRUDE MORE THAN 1/2" TO PREVENT INGRESS OF MULCH OR EARTH.

**7 TREE IRRIGATION @ DECOMPOSED GRANITE AREAS** Scale: N.T.S.

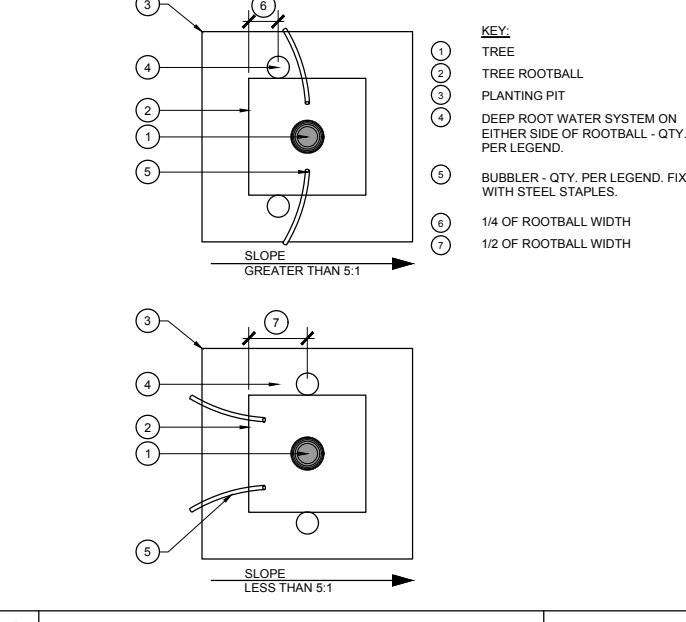

- 1 TREE
- 2 TREE ROOTBALL
- 3 PLANTING PIT
- 4 DEEP ROOT WATER SYSTEM ON EITHER SIDE OF ROOTBALL - QTY. PER LEGEND.
- 5 BUBBLER - QTY. PER LEGEND. FIX WITH STEEL STAPLES.
- 6 1/4 OF ROOTBALL WIDTH
- 7 1/2 OF ROOTBALL WIDTH

**6 TREE BUBBLER ASSEMBLY AT BOX TREE** Scale: N.T.S.

REV. NO.	DATE	DESCRIPTION	BY

MOORE IACOFANO GOLTSMAN, INC.  
317 LEXINGTON AVENUE, SUITE 2  
SAN ANTONIO, TEXAS, CA 78215  
TEL 210-600-9990  
WWW.MIGCOM.COM

**PAPE-DAWSON ENGINEERS**  
SAN ANTONIO | AUSTIN | HOUSTON | FORT WORTH | DALLAS  
3800 NW LOOP 416 | SAN ANTONIO, TX 78215 | 210.325.9999  
TEXAS ENGINEERING FIRM #479 | TEXAS SURVEYING FIRM #1088999

CITY OF SAN ANTONIO  
PUBLIC WORKS DEPARTMENT

DOLOROSA

LANDSCAPE IRRIGATION DETAILS

SHEET 2 OF 5

DESIGN	CHECKED	DRAWN	PROJECT NO.	SUBMITTAL	SHEET NO.
RD/AM	RD/AM	TM/RD	23-03763	70%	354



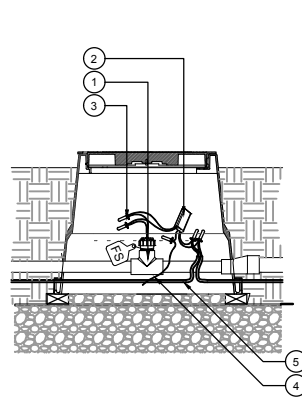

- 1 FLOW SENSOR PER LEGEND AND SPECS.
- 2 ICD-SENSOR DECODER PER LEGEND AND SPECS.
- 3 WATERPROOF CONNECTORS PER SPECS
- 4 2-WIRE PATH PER LEGEND AND SPECS.
- 5 TO EARTH GROUND. SEE DETAIL ##.

**NOTES:**

- ALL WORK SHALL BE AS PER CONTROLLER MANUFACTURER'S RECOMMENDATIONS.
- EARTH GROUND TO BE A MINIMUM OF 8- FEET AWAY FROM SENSOR DECODER AND AT A RIGHT ANGLE TO THE TWO WIRE PATH.
- PROVIDE 24" LONG EXPANSION COILS AT EACH WIRE CONNECTION.
- ALL THREADED FITTINGS MUST HAVE 3/4" TEFLON TAPE.

**2 2-WIRE SENSOR DECODER** Scale: 1" = 1'-0"

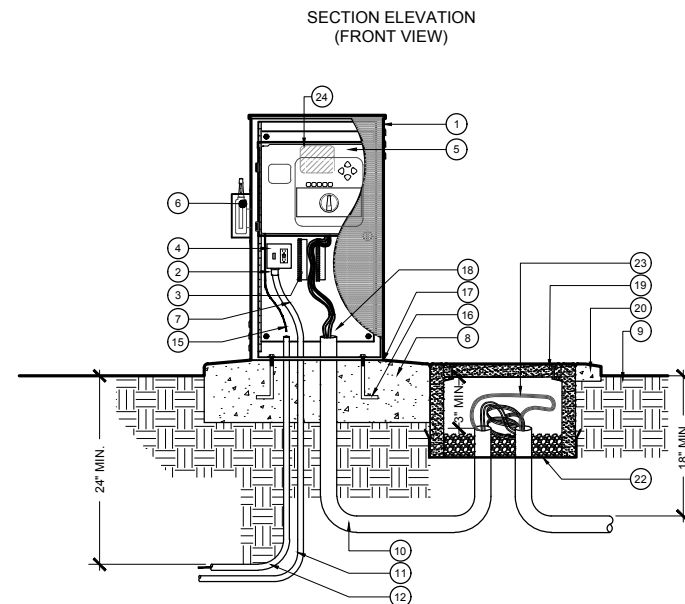
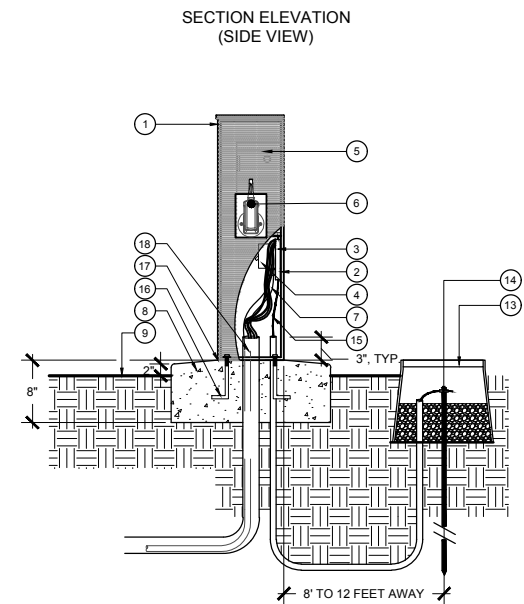

- 1 FRONT ENTRY STAINLESS STEEL NEMA TYPE 3R RAINPROOF ENCLOSURE (UL LISTED). ENCLOSURE DIMENSIONS 18" WIDE X 36" HIGH X 12" DEEP.
- 2 CONTROLLER SUBASSEMBLY: 120 VOLT, 15 AMP, GROUND FAULT PROTECTED DUPLEX WITH RECEPTACLE AND LOCKING SWITCH. INCLUDES CONDUIT AND CONDULET, TERMINAL STRIPS AND PLACARDS. FACTORY MOUNTED TO STAINLESS STEEL BACKBOARD.
- 3 TERMINAL STRIP FOR REMOTE CONTROL VALVE WIRE CONNECTIONS. INCLUDED WITH CONTROLLER SUBASSEMBLY SPECIFIED.
- 4 POWER SWITCH/GFCI RECEPTACLE. INCLUDED WITH CONTROLLER SUBASSEMBLY SPECIFIED.
- 5 AUTOMATIC IRRIGATION CONTROLLER PER LEGEND AND SPECS MOUNTED TO STAINLESS BACKBOARD PER MFG'R RECOMMENDATIONS. REMOVE CONTROLLER DOOR PRIOR TO MOUNTING.
- 6 WIRELESS WEATHER SENSOR RECEIVER PER LEGEND AND SPECS. MOUNT WITH VANDAL RESISTANT WIRELESS RECEIVER GUARD, HUNTER MODEL WR-GUARD OR APPROVED EQUAL
- 7 120V POWER SERVICE IN ELECTRICAL FLEX CONDUIT.
- 8 8" MIN. THICK, POURED-IN-PLACE CONCRETE PAD WITH 1/2% SLOPE TOWARD EDGES FOR DRAINAGE AND WITH ANCHOR BOLTS PER MANUFACTURER RECOMMENDATIONS. 1/2" RADIUS AT ALL EDGES. CONCRETE SHALL HAVE LIGHT BROOM FINISH. SLOPE PAD WAY FROM CONTROLLER TO DRAIN. PAD SHALL EXTEND 6" BEYOND FACE OF ENCLOSURE.
- 9 FINISH GRADE
- 10 2" SCH. 40 PVC CONDUIT AND SWEEP FOR REMOTE CONTROL WIRES
- 11 1" SCH. 40 PVC CONDUIT AND SWEEP FOR 120VAC POWER CONDUCTOR. 24" MIN. BURIAL DEPTH. REFER TO ELECTRICAL DWGS.
- 12 1" SCH. 40 PVC CONDUIT AND SWEEP ELL FOR GROUND WIRE
- 13 10" ROUND VALVE BOX AROUND GROUND ROD. FILL WITH 3/4" WASHED PEA GRAVEL.
- 14 5/8" DIAMETER X 8' LONG COPPER CLAD GROUND ROD WITH #6 GROUND WIRE AND CLAMP. LOCATE 8'-12' FROM ENCLOSURE.
- 15 #6 GROUND WIRE SECURED TO CONTROLLER GROUNDING TERMINAL.
- 16 ANCHOR BOLTS. SET IN WET CONCRETE FOOTING USING TEMPLATE.
- 17 SEAL INTERIOR OF CABINET WITH DUCT SEAL
- 18 SEAL ENDS WITH DUCT SEAL AFTER WIRE INSTALLATION, TYP.
- 19 PRECAST CONCRETE PULL BOX. LOCATE DIRECTLY ADJACENT TO CONCRETE FOOTING.
- 20 6" DEEP CONCRETE COLLAR, TYP. OF (3) EDGES.
- 21 3 CU. FT. 3/8" PEA GRAVEL
- 22 LANDSCAPE FABRIC AND 1/4" GALV. WIRE MESH, TYP.
- 23 PROVIDE 36" EXPANSION COILS AT ALL WIRE RUNS.
- 24 PROVIDE CUSTOM DECAL WITH CONTROLLER ID ON THE EXTERIOR FRONT FACE OF THE CONTROLLER.

**3 AUTOMATIC IRRIGATION CONTROLLER (PEDESTAL MOUNT)** Scale: N.T.S.

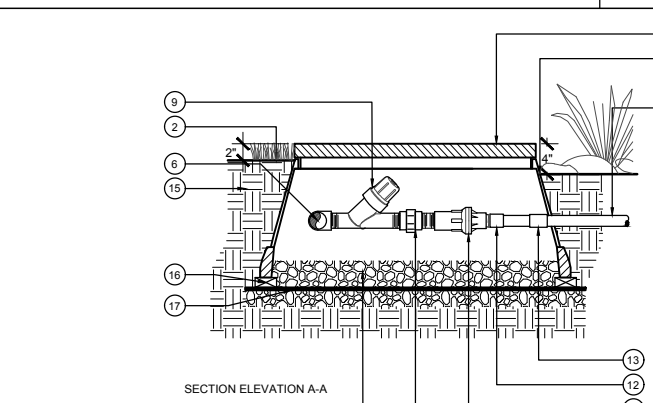
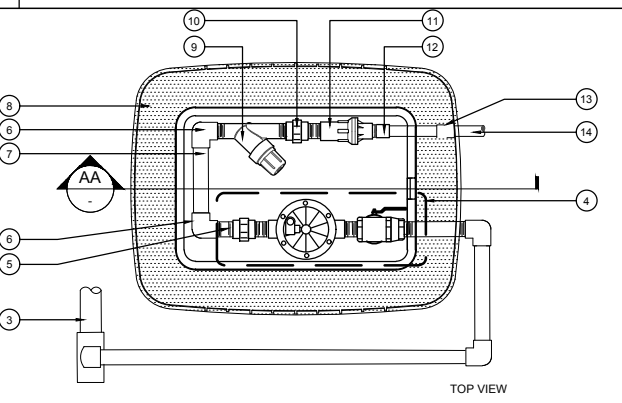

- 1 FINISH GRADE AT PLANTER
- 2 FINISH GRADE AT TURF AREA
- 3 IRRIGATION PRESSURE MAINLINE OR MANIFOLD SUPPLY
- 4 REMOTE CONTROL VALVE. REFER TO DETAIL 1/4.07
- 5 SCH. 80 PVC NIPLLE. 3" MIN. LENGTH
- 6 SCH. 80 PVC ELL (TxT)
- 7 SCH. 80 PVC NIPLLE. LENGTH AS REQ.
- 8 JUMBO RECTANGULAR VALVE BOX WITH LOCKING COVER AND SS LOCKING BOLT
- 9 SCREEN FILTER. SEE LEGEND AND SPECS
- 10 SCH. 80 PVC UNION
- 11 PRESSURE REGULATOR. SEE LEGEND AND SPECS
- 12 SCH. 80 PVC MALE ADAPTER
- 13 SCH. 40 PVC COUPLING
- 14 IRRIGATION LATERAL LINE. SEE LEGEND AND SPECS
- 15 NATIVE SOIL COMPACTED
- 16 BRICK SUPPORTS, TYP. OF 4
- 17 LANDSCAPE FABRIC AND 1/4" GALV. WIRE MESH, TYP.
- 18 3 CU. FT. 3/4" PEA GRAVEL

**5 REMOTE CONTROL DRIP VALVE ASSEMBLY** Scale: N.T.S.

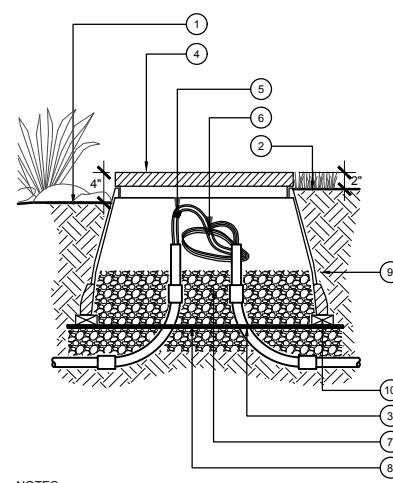

- 1 FINISH GRADE AT PLANTER
- 2 FINISH GRADE AT TURF AREA
- 3 PVC SCH. 40 ELECTRICAL CONDUIT AND SWEEPS TO DEPTH PER SPECS
- 4 RECTANGULAR VALVE BOX W/ BOLT DOWN COVER, AND SS HARDWARE
- 5 APPROVED WIRE CONNECTOR (IF APPLICABLE)
- 6 36" EXPANSION COIL
- 7 3 CU. FT. 3/8" PEA GRAVEL
- 8 LANDSCAPE FABRIC AND 1/4" GALV. WIRE MESH, TYP.
- 9 NATIVE SOIL COMPACTED TO
- 10 (4) CONCRETE BRICK SUPPORTS, ONE AT EACH CORNER

**NOTES:**

- ALL WIRING MUST CONFORM TO LOCAL CODES.
- PROVIDE 36" EXPANSION COILS AT EACH WIRE CONNECTION.
- PROVIDE 3" CLEARANCE BETWEEN WIRES AND LID.
- NO WIRE SPLICES ARE ALLOWED WITHOUT OWNER'S REPRESENTATIVE APPROVAL.

**1 PULL BOX** Scale: N.T.S.

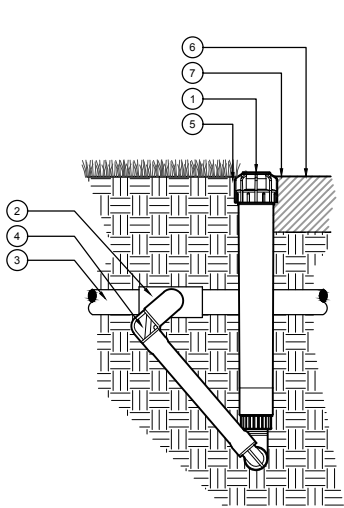

- 1 DRIP OPERATION INDICATOR
  - 2 1/2" FPT CONNECTION FROM IRRIGATION LATERAL LINE
  - 3 IRRIGATION LATERAL PIPE
  - 4 SWING JOINT
  - 5 FINISH GRADE IN LAWN. INSTALL INDICATOR FLUSH WITH FINISH GRADE IN TURF AREA.
  - 6 ADJACENT MULCH
  - 7 FINISH GRADE IN PLANTER AREA. INSTALL INDICATOR 1/2" ABOVE FINISH GRADE OF MULCH IN SHRUB AND GROUND COVER AREAS
- NOTES:**
- LOCATE INDICATOR WITHIN AN AREA ADJACENT TO A WALKWAY, CURB, ETC. AND AWAY FROM PLANT MATERIALS TO PROVIDE EASY VISUAL CONFIRMATION FROM A DISTANCE OF OPERATION.
  - COMPACT SOIL AROUND INDICATOR TO THE SAME DENSITY AS ADJACENT SOIL.

**4 DRIP OPERATION INDICATOR** Scale: N.T.S.

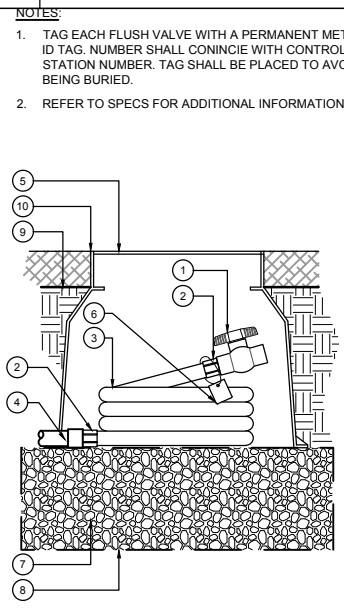

- NOTES:**
- TAG EACH FLUSH VALVE WITH A PERMANENT METAL ID TAG. NUMBER SHALL CONINCIE WITH CONTROLLER STATION NUMBER. TAG SHALL BE PLACED TO AVOID BEING BURIED.
  - REFER TO SPECS FOR ADDITIONAL INFORMATION.
- 1 SCH. 40 PVC. BALL VALVE PER LEGEND.
  - 2 IRRIGATION HOSE FITTING
  - 3 1/2" SIZE IRRIGATION HOSE. 30" MIN. LENGTH. COIL INSIDE VALVE BOX.
  - 4 PVC EXHAUST HEADER PER PLANS AND LEGEND.
  - 5 10" ROUND VALVE BOX WITH LOCKING COVER AND SS BOLT
  - 6 VALVE ID TAG. SEE NOTE #1.
  - 7 3/4" CRUSHED DRAIN ROCK. 6" MIN. DEPTH. EXTEND 6" BEYOND ALL EDGES OF VALVE BOX
  - 8 1/4" GALV. WIRE CLOTH. WRAP AROUND CRUSHED ROCK.
  - 9 FINISH GRADE
  - 10 SET VALVE BOX FLUSH WITH TOP OF MULCH LAYER.

**6 MANUAL FLUSH VALVE** Scale: N.T.S.

REV. NO.	DATE	DESCRIPTION	BY

**MIG MOORE IACOFANO GOLTSMAN, INC.**  
317 LEXINGTON AVENUE, SUITE 2  
SAN ANTONIO, TEXAS, CA 78215  
TEL 210-600-9990  
www.migcom.com

**PAPE-DAWSON ENGINEERS**  
SAN ANTONIO | AUSTIN | HOUSTON | FORT WORTH | DALLAS  
3800 HWY 149P-418 | SAN ANTONIO, TX 78216 | 210.325.9999  
TEXAS ENGINEERING FIRM #479 | TEXAS SURVEYING FIRM #10088999

**CITY OF SAN ANTONIO  
PUBLIC WORKS DEPARTMENT**

**DOLOROSA**

**LANDSCAPE IRRIGATION DETAILS**

SHEET 3 OF 5

DESIGN	CHECKED	DRAWN	PROJECT NO.	SUBMITTAL	SHEET NO.
RD/AM	RD/AM	TM/RD	23-03763	70%	355

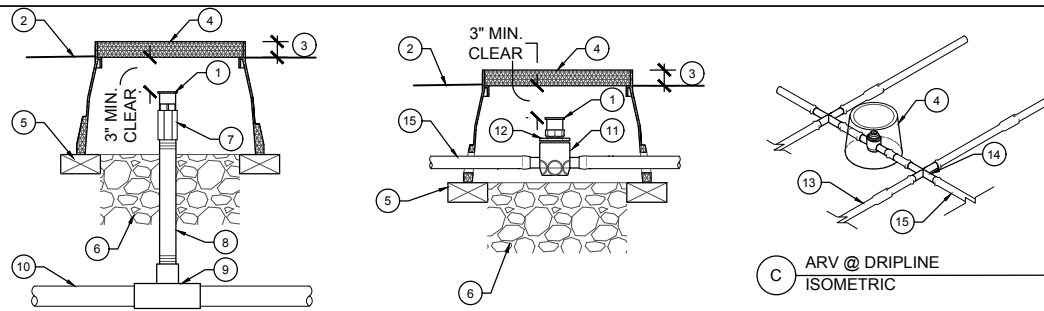

**NOTES:**  
 1. ARV VALVES SHALL BE INSTALLED IN VALVE BOXES AT HIGHEST POINTS WITHIN SUB-SURFACE DRIP SYSTEM PER MNFR GUIDELINES.  
 2. SEE LEGEND FOR LATERAL DEPTH AND SPACING.

- A ARV PLUMBED TO PVC PIPE SECTION ELEVATION**
- 1 AIR VACUUM/RELIEF VALVE, REFER TO LEGEND
  - 2 FINISH GRADE
  - 3 SET TOP OF VALVE BOX ABOVE FINISH GRADE: 1/2" IN SEED, 1-1/2" IN SOD, 2-1/2" IN PLANTER
  - 4 10" ROUND VALVE BOX, SEE SPECS.
  - 5 THREE (3) COMMON BRICKS FOR SUPPORT. CENTER EACH UNDER EDGE OF VALVE BOX EQUIDISTANT FROM EACH OTHER.
  - 6 3/4" CRUSHED ROCK, 6" MIN. DEPTH.
- B ARV PLUMBED TO DRIPLINE SECTION ELEVATION**
- 7 1/2" PVC SCH. 80 COUPLING (THxTH)
  - 8 1/2" PVC SCH. 80 NIPPLE (LENGTH AS REQ.)
  - 9 PVC REDUCTION TEE WITH 1/2" FEMALE THREADED INLET
  - 10 PVC NON-PRESSURE LATERAL LINE. SIZE AND TYPE PER PLAN
  - 11 3/4" FPT COMBINATION TEE (INS x INS x TH)
- C ARV @ DRIPLINE ISOMETRIC**
- 12 1/2" MPT REDUCER BUSHING.
  - 13 DRIPLINE, TYPE AND DEPTH PER LEGEND
  - 14 BARBED INSERT TEE FITTING, TYP.
  - 15 BLANK POLYETHYLENE TUBING, TYP.

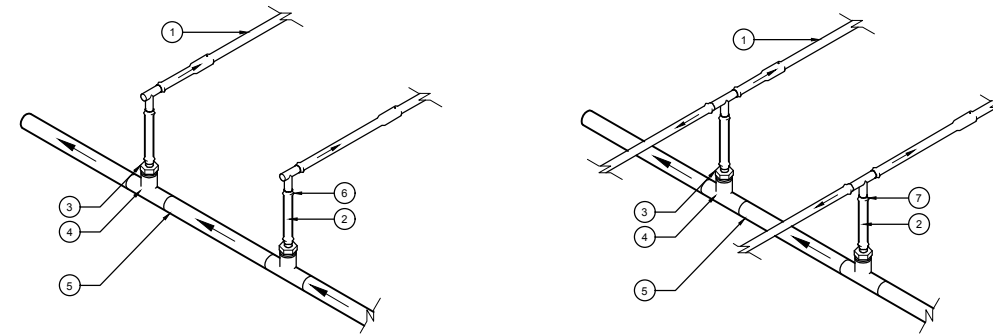

**A END FEED MANIFOLD SUPPLY ISOMETRIC**      **B CENTER FEED MANIFOLD SUPPLY ISOMETRIC**

- 1 DRIPLINE, TYPE AND DEPTH PER IRRIGATION LEGEND
- 2 BLANK POLYETHYLENE TUBING
- 3 BARB X MPT ADAPTER
- 4 SCH. 40 PVC TEE WITH FPT OUTLET
- 5 NON-PRESSURE LATERAL DOWNSTREAM FROM DRIP REMOTE CONTROL VALVE ASSEMBLY
- 6 BARBED INSERT 90° ELL FITTING
- 7 BARBED INSERT TEE FITTING

**2 AIR VACUUM/ RELIEF VALVE**

Scale: N.T.S.

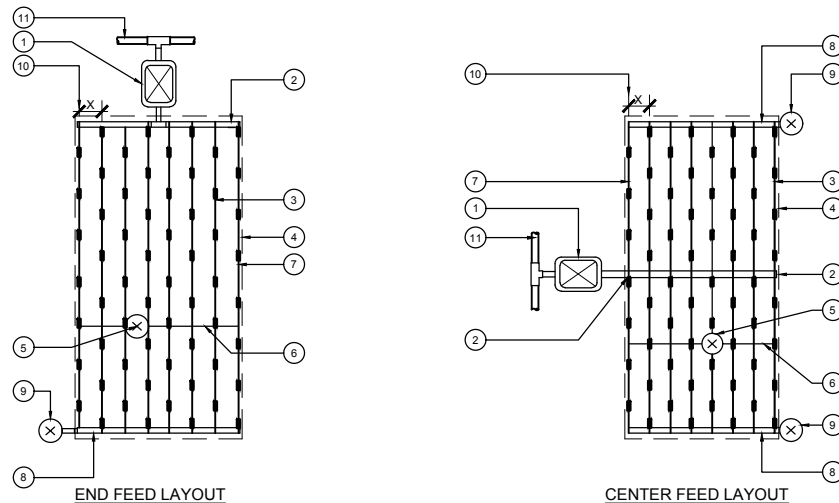

**END FEED LAYOUT**

**CENTER FEED LAYOUT**

- 1 DRIP REMOTE CONTROL VALVE ASSEMBLY, REFER TO IRRIGATION PLANS AND LEGEND
- 2 IRRIGATION NON-PRESSURE PVC LATERAL SUPPLY LINE (HEADER), PER IRRIGATION PLANS AND LEGEND
- 3 DRIPLINE TUBING LATERAL PER IRRIGATION LEGEND
- 4 PLANTING AREA PERIMETER
- 5 AIR/VACUUM RELIEF VALVE PER IRRIGATION LEGEND. INSTALL AT HIGH POINT(S) OF HYDROZONE. LOCATE IN FIELD.
- 6 AIR/VACUUM RELIEF LATERAL BLANK DRIPLINE TUBING. CONNECT PERPENDICULAR TO DRIPLINE USING MANUFACTURER APPROVED FITTINGS
- 7 INSTALL PERIMETER DRIPLINE LATERALS 2" TO 4" FROM EDGE OF HARDSCAPE, CURB, ETC.
- 8 IRRIGATION NON-PRESSURE PVC EXHAUST HEADER.
- 9 FLUSH VALVE PER IRRIGATION LEGEND. PLUMB TO NON-PRESSURE PVC LATERAL LINE
- 10 DISTANCES PER IRRIGATION LEGEND
- 11 IRRIGATION PRESSURE MAINLINE PER PLANS AND SPECS.

**1 DRIPLINE MANIFOLD SUPPLY**

Scale: N.T.S.

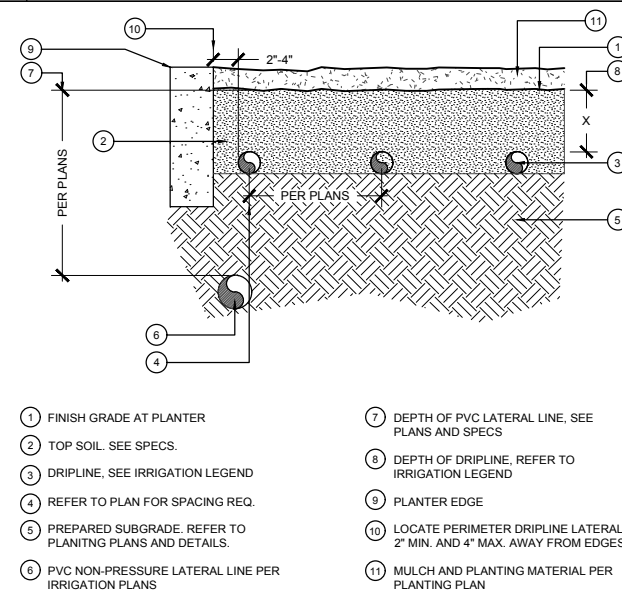

- 1 FINISH GRADE AT PLANTER
- 2 TOP SOIL. SEE SPECS.
- 3 DRIPLINE. SEE IRRIGATION LEGEND
- 4 REFER TO PLAN FOR SPACING REQ.
- 5 PREPARED SUBGRADE. REFER TO PLANTING PLANS AND DETAILS.
- 6 PVC NON-PRESSURE LATERAL LINE PER IRRIGATION PLANS
- 7 DEPTH OF PVC LATERAL LINE. SEE PLANS AND SPECS
- 8 DEPTH OF DRIPLINE, REFER TO IRRIGATION LEGEND
- 9 PLANTER EDGE
- 10 LOCATE PERIMETER DRIPLINE LATERALS 2" MIN. AND 4" MAX. AWAY FROM EDGES.
- 11 MULCH AND PLANTING MATERIAL PER PLANTING PLAN

**4 DRIPLINE LAYOUT (TYPICAL)**

Scale: N.T.S.

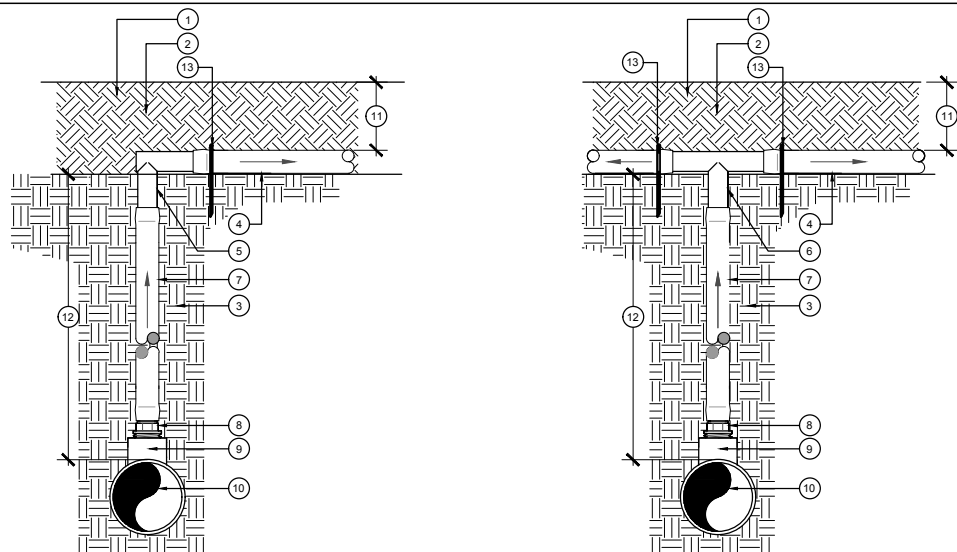

**A MANIFOLD-ELL CONDITION SECTION ELEVATION**

**B MANIFOLD-TEE CONDITION SECTION ELEVATION**

- 1 FINISH GRADE AT PLANTER
- 2 TOP SOIL. REFER TO SPECS
- 3 COMPACTED SUBGRADE. REFER TO SPECS.
- 4 DRIPLINE TUBING, REFER TO IRRIGATION LEGEND FOR ADDITIONAL INFORMATION
- 5 BARBED DRIP ELBOW FITTING
- 6 BARBED DRIP TEE FITTING
- 7 BLANK POLYETHYLENE DRIP TUBING
- 8 BARBED x 1/2" MPT ADAPTER
- 9 PVC TEE (SLxSLxTH) WITH 1/2" FPT INLET
- 10 PVC SUPPLY LATERAL LINE. SIZE AND TYPE PER PLAN
- 11 DEPTH OF MULCH, REFER TO SPECS.
- 12 DEPTH OF PVC LATERAL LINE. REFER TO IRRIGATION LEGEND
- 13 4" GALVANIZED STAPLE. INSTALL OVER TUBING AT SPACING PER SPECS

**3 SUBSURFACE DRIPLINE**

Scale: N.T.S.

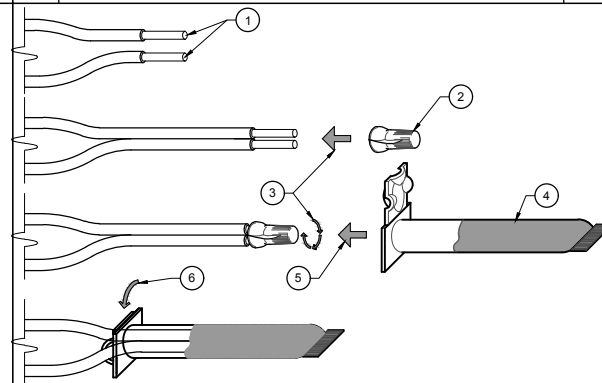

- 1 STRIP, CLEAN AND DRY WIRES APPROXIMATELY 5/8" FROM END AND INSERT WIRES THROUGH HOLES IN BASE OF BODY
- 2 ELECTRICAL CONNECTOR
- 3 APPLY ELECTRICAL CONNECTOR AND TWIST CLOCKWISE
- 4 GEL-FILLED INSULATOR
- 5 INSERT SPLICE INTO GEL-FILLED INSULATOR TUBE. PUSH PAST THE LOCKING FINGERS TO HOLD ELECTRICAL CONNECTOR IN PLACE.
- 6 POSITION WIRE CHANNELS AND SNAP INSULATOR TUBE COVER CLOSED.

**6 DRIPLINE TO PVC LATERAL LINE TRANSITION (SUPPLY AND EXHAUST HEADER)**

Scale: N.T.S.

**5 DRY SPLICE CONNECTION**

Scale: NTS

REV. NO.	DATE	DESCRIPTION	BY

**MIG MOORE IACOFANO GOLTSMAN, INC.**  
 317 LEXINGTON AVENUE, SUITE 2    TEL 210-600-9990  
 SAN ANTONIO, TEXAS, CA 78215    www.migcom.com

**Pape-Dawson ENGINEERS**  
 SAN ANTONIO | AUSTIN | HOUSTON | FORT WORTH | DALLAS  
 3800 NW LOOP 416 | SAN ANTONIO, TX 78217 | 210.325.9999  
 TEXAS ENGINEERING FIRM #479 | TEXAS SURVEYING FIRM #10888899

**CITY OF SAN ANTONIO PUBLIC WORKS DEPARTMENT**

**DOLOROSA**

**LANDSCAPE IRRIGATION DETAILS**

SHEET 4 OF 5

DESIGN	CHECKED	DRAWN	PROJECT NO.	SUBMITTAL	SHEET NO.
RD/AM	RD/AM	TM/RD	23-03763	70%	356

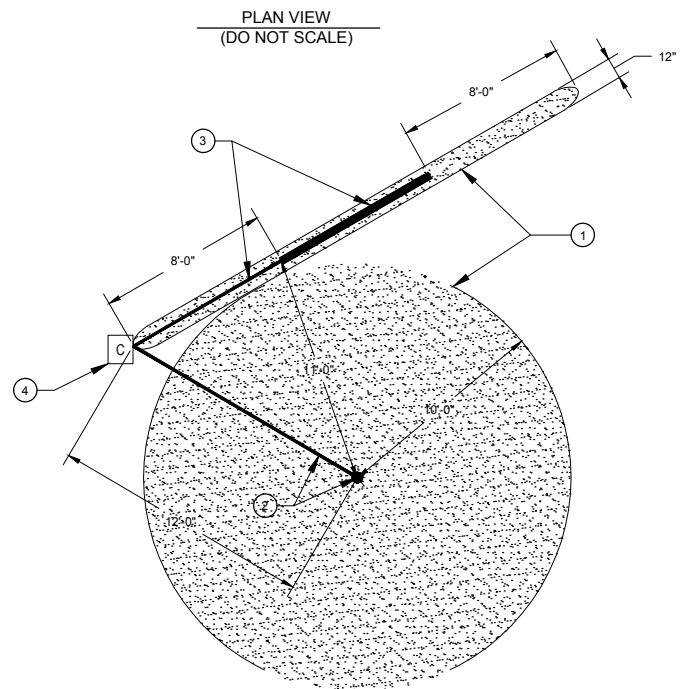

- ① ELECTRODE SPHERE OF INFLUENCE BOUNDARIES.
- ② GROUND ROD WITH PRE-WELDED INSULATED CONDUCTOR (5/8" DIA. X 10' LONG). DRIVE INTO GROUND IN A VERTICAL POSITION OR AN OBLIQUE ANGLE NOT TO EXCEED 45°. USE WHEN POSSIBLE TO DRIVE STAKE INTO GROUND.
- ③ COPPER GROUND PLATE WITH PRE-WELDED INSULATED CONDUCTOR (SIZE: 4" X 96" X 0.0625"). USE WHEN IMPOSSIBLE TO DRIVE STAKE INTO GROUND OR WHEN DIRECTED BY CONTROLLER MANUFACTURER.
- ④ AUTOMATIC IRRIGATION CONTROLLER. REFER TO IRRIGATION LEGEND AND DWGS.
- ⑤ PVC SWEEP ELL, 1-1/2" MIN.
- ⑥ EARTH CONTACT MATERIAL
- ⑦ FINISH GRADE
- ⑧ 30" MINIMUM OR BELOW FROST LINE, WHICHEVER IS DEEPER.

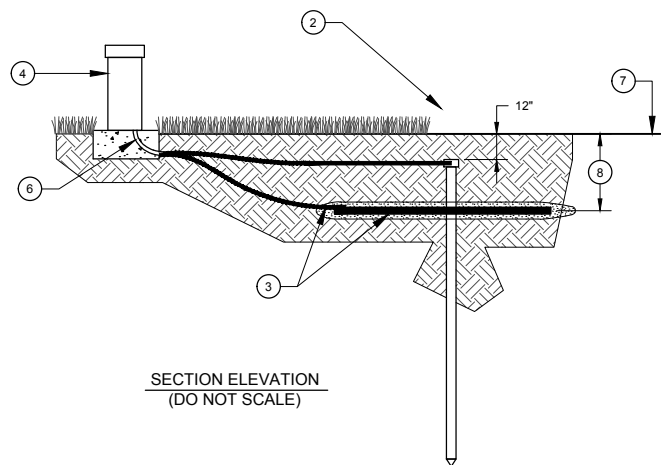

- NOTES:**
1. THE GROUND GRID COMPONENTS MUST BE INSTALLED WITH THE DIMENSIONAL RELATIONSHIP SHOWN IN THE DETAIL. DO NOT INSTALL ANY OTHER WIRES, CABLES, AND ELECTRONIC EQUIPMENT WITHIN THE SPHERE OF INFLUENCE OF THE GROUNDING ELECTRODES.
  2. INSTALLATION OF ALL COMPONENTS AND MUST MEET OR EXCEED THE AMERICAN SOCIETY OF IRRIGATION CONSULTANTS (ASIC) EARTH GROUNDING GUIDELINES AND BE AS APPROVED BY AUTOMATIC IRRIGATION CONTROLLER MANUFACTURER'S.
  3. IT IS THE RESPONSIBILITY OF THE CONTRACTOR TO CONNECT THE CONTROLLER TO EARTH GROUND IN ACCORDANCE WITH ARTICLE 250 OF THE NATIONAL ELECTRICAL CODE (NEC).
  4. WHEN UTILIZING THE COPPER GROUND PLATE METHOD, THE CONTRACTOR SHALL UTILIZE A MINIMUM OF 100 LBS OF EARTH CONTACT MATERIAL. SPREAD MATERIAL SO THAT IT SURROUNDS THE COPPER PLAT EVENLY ALONG ITS LENGTH WITHIN A 6" WIDE TRENCH.
  5. SALTS, FERTILIZERS, BENTONITE CLAY, CEMENT, COKE, CARBON, AND OTHER CHEMICALS ARE NOT BE USED TO IMPROVED SOIL CONDUCTIVITY.
  6. ALL GROUNDING ELECTRODES SHALL BE UL LISTED OR MANUFACTURED TO MEET NEC CODE.
  7. NO SPLICES ALLOWED UNLESS USING EXOTHERMIC WELDING PROCESS AND APPROVED BY CITY'S REPRESENTATIVE.
  8. INSTALL ALL GROUNDING CIRCUIT COMPONENTS IN STRAIGHT LINES. WHEN NECESSARY TO MAKE A TURN OR BEND, IT SHALL BE DONE IN A SWEEPING CURVE WITH A MINIMUM RADIUS OF 6" AND A MINIMUM INCLUDED ANGLE OF 90°.
  9. THE EARTH-TO-GROUND RESISTANCE IS TO BE MEASURED USING A MEGGER OR OTHER SIMILAR INSTRUMENT, AND THE READING IS TO BE NO MORE THAN 10 OHMS. IF THE RESISTANCE IS MORE THAN 10 OHMS, ADDITIONAL GROUND PLATES AND EARTH CONTACT MATERIAL ARE TO BE INSTALLED USING ASIC GUIDELINES.
  10. IT IS REQUIRED THAT THE SOIL SURROUNDING COPPER ELECTRODES WITHIN THE SPHERE OF INFLUENCE BE KEPT AT A MINIMUM MOISTURE LEVEL OF 15% (BY VOLUME) AT ALL TIMES.
  11. ALL GROUNDING COMPONENTS MUST BE CONNECTED TO THE EQUIPMENT BEFORE ANY OTHER CONNECTION IS MADE.

**1 GROUNDING ROD/PLATE**

Scale: N.T.S.

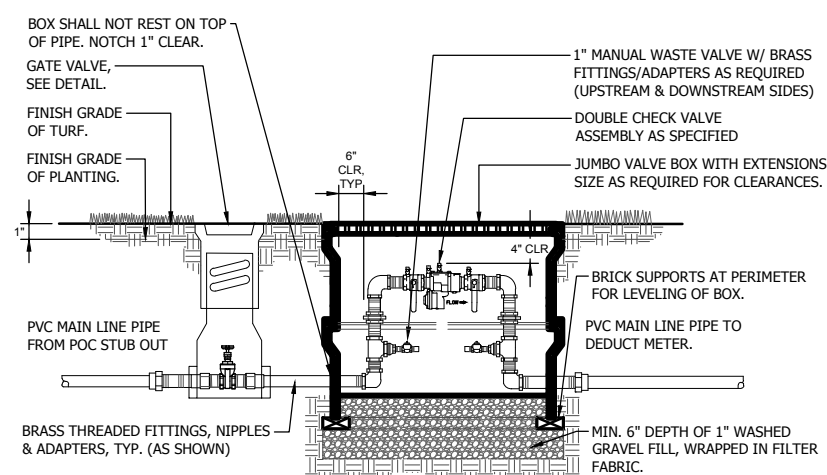

- NOTES:**
1. INSTALL QUICK COUPLING VALVE IMMEDIATELY DOWNSTREAM FROM DCVA FOR WINTERIZATION PURPOSES.
  2. DCVA TO BE ENCLOSED IN VALVE BOX. ALLOW SUFFICIENT ROOM FOR ACCESS TO VALVES AND TEST COCKS.
  3. ALL THREADED FITTINGS TO BE TEFLON PASTE COATED PRIOR TO CONNECTION.
  4. ASSEMBLY TO BE TESTED AFTER INSTALLATION BY A CERTIFIED BACKFLOW TESTER PRIOR TO OPERATING SYSTEM.

**2 DOUBLE CHECK VALVE BACKFLOW PREVENTER IN VAULT**

Scale: N.T.S.

REV. NO.	DATE	DESCRIPTION	BY

**MIG** MOORE IACOFANO GOLTSMAN, INC.  
317 LEXINGTON AVENUE, SUITE 2  
SAN ANTONIO, TEXAS, CA 78215  
TEL 210-600-9990  
www.migcom.com

**PAPE-DAWSON ENGINEERS**  
SAN ANTONIO | AUSTIN | HOUSTON | FORT WORTH | DALLAS  
3800 HWY 198P-418 | SAN ANTONIO, TX 78218 | 210.325.9999  
TEXAS ENGINEERING FIRM #479 | TEXAS SURVEYING FIRM #10888899

**CITY OF SAN ANTONIO**  
**PUBLIC WORKS DEPARTMENT**

**DOLOROSA**

**LANDSCAPE IRRIGATION DETAILS**

SHEET 5 OF 5

DESIGN	CHECKED	DRAWN	PROJECT NO.	SUBMITTAL	SHEET NO.
RD/AM	RD/AM	TM/RD	23-03763	70%	357

# PLANT SCHEDULE

# PLANTING NOTES

## SHADE TREES

CODE	BOTANICAL NAME / COMMON NAME	CONT	QTY	WATER USE
QUE MUH	Quercus muhlenbergii / Chinkapin Oak	100 Gal. / 4" Cal.	19	MEDIUM
QUE POL	Quercus polymorpha `Monterey` / Monterey Oak	100 Gal. / 4" Cal.	49	MEDIUM
ULM CRA	Ulmus crassifolia / Cedar Elm	100 Gal. / 4" Cal.	24	LOW

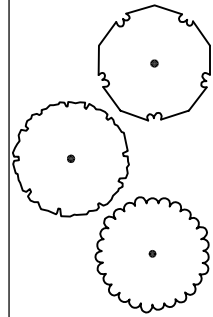

## UNDERSTORY & SMALL TREES

CODE	BOTANICAL NAME / COMMON NAME	CONT	QTY	WATER USE
CER TEX	Cercis canadensis texensis / Texas Redbud	65 Gal.	17	LOW
SOP SEC	Sophora secundiflora / Mountain Laurel	65 Gal.	28	MEDIUM

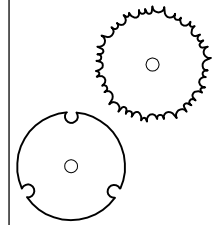

Add inch caliber for mitigation

## SHRUBS

CODE	BOTANICAL NAME / COMMON NAME	CONT	QTY	WATER USE
DIE GRA	Dietes grandiflora / African Iris	2 Gal.	130	LOW
CYA FAL	Cyrtomium falcatum / Holly Fern	2 Gal.	28	LOW
HAM PAT	Hamelia patens / Firebush	3 Gal.	47	LOW
MAH AQU	Mahonia aquifolium / Mahonia	3 Gal.	71	MEDIUM
MAL ARB	Malvaviscus arboreus drummondii / Turks Cap	5 Gal.	69	MEDIUM
PLU AUR	Plumbago auriculata / Blue Plumbago	5 Gal.	270	MODERATE
SAL FAR	Salvia farinacea 'Henry Duelberg' / Blue Salvia	2 Gal.	208	MODERATE
SAL GRE	Salvia gregii 'Sierra Linda' / Pink Autumn Salvia	2 Gal.	208	LOW
STA COC	Stachys coccinea / Texas Betony	1 Gal.	164	LOW



NOTE: 50% BLUE AND 50% PINK SALVIA, MIX EVERY OTHER PLANT IN LAYOUT

## YUCCA, AGAVE, & CACTUS

CODE	BOTANICAL NAME / COMMON NAME	CONT	QTY	WATER USE
HES PAR	Hesperaloe parvifolia / Red Yucca	5 Gal.	16	VERY LOW
YUC REC	Yucca recurvifolia / Soft Leaf Yucca	5 Gal.	12	VERY LOW

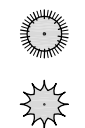

## GROUND COVERS

CODE	BOTANICAL NAME / COMMON NAME	CONT	SPACING	QTY	WATER USE
LIR MUS	Liriope muscari / Liriope	1 Gal.	12" o.c.	2,033 SF	MEDIUM
SCU SUF	Scutellaria suffrutescens / Pink Skullcap	1 Gal.	12" o.c.	93	LOW

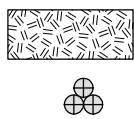

- THE PLANTING PLANS INDICATE PLANTING LOCATION AND QUANTITIES. THE CONTRACTOR SHALL VERIFY ALL QUANTITIES. THE AREAS OF GROUND COVER AND PERENNIAL PLANTINGS ARE APPROXIMATE. THE CONTRACTOR SHALL BE RESPONSIBLE FOR PROVIDING THE REQUIRED NUMBER OF PLANTS TO COVER THE AREAS SHOWN ON THESE PLANS.
- REFER TO THE PLANT LIST FOR PLANT SIZES. REFER TO THE SPECIFICATIONS FOR SOIL PREPARATION, SOIL AMENDMENTS, FERTILIZER AND ADDITIONAL PLANTING REQUIREMENTS.

REV. NO.	DATE	DESCRIPTION	BY

**MIG** MOORE IACOFANO GOLTSMAN, INC.  
317 LEXINGTON AVENUE, SUITE 2 SAN ANTONIO, TEXAS, CA 78215 TEL 210-600-9990 www.migcom.com

**PAPE-DAWSON ENGINEERS**  
SAN ANTONIO | AUSTIN | HOUSTON | FORT WORTH | DALLAS  
2000 NW LOOP 410 | SAN ANTONIO, TX 78218 | 210.875.9000  
TEXAS ENGINEERING FIRM #170 | TEXAS SURVEYING FIRM #10028800

CITY OF SAN ANTONIO  
**PUBLIC WORKS DEPARTMENT**

DOLOROSA

**PLANTING SCHEDULE**

DESIGN	CHECKED	DRAWN	PROJECT NO.	SUBMITTAL	SHEET NO.
RD/AM	RD/AM	TM/RD	23-03763	70%	358

**NOTES:**

- CUT ROOTBALL AS REQUIRED TO LOOSEN ROOTS AND PREVENT CIRCLING
- THOROUGHLY WATER EACH PLANTING HOLE DURING BACKFILLING
- MULCH: APPROVED UNTREATED ARBOR CHIP MULCH FROM TREE AND SHRUB TRIMMING. NO BARK MULCH.

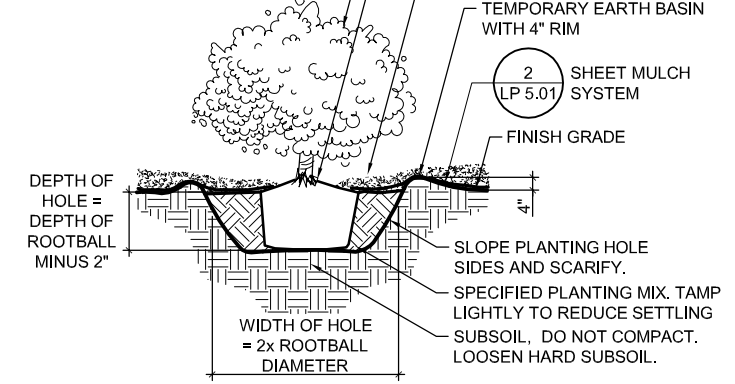

**1 GALLON AND LARGER PLANTS**

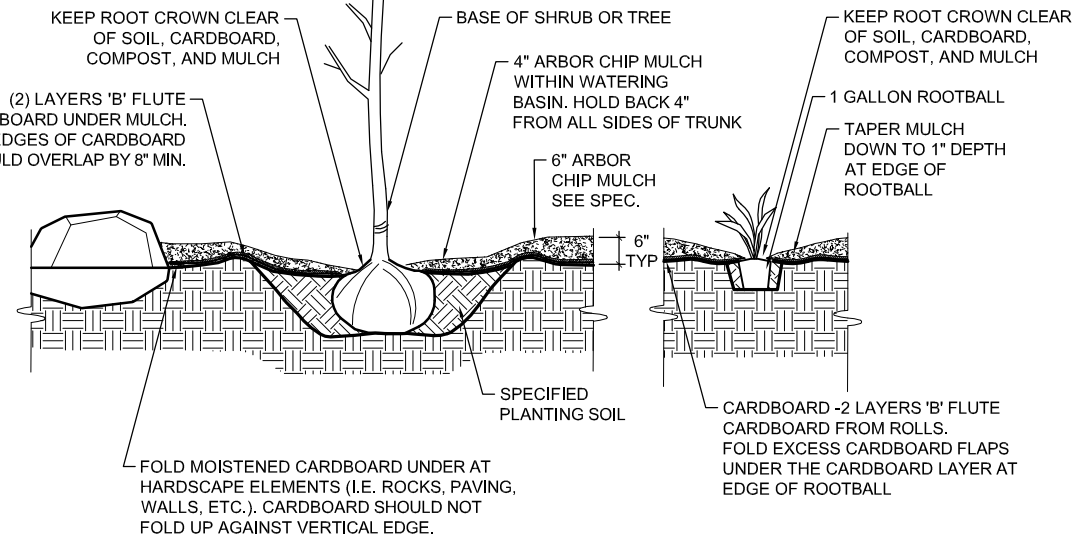

**TREES & SHRUBS**

**1 GALLON PLANTS**

**SHEET MULCH PROCEDURE:**

- AMEND SOIL AS DIRECTED IN SPECIFICATIONS. NOTE THAT ALL SYNTHETIC FERTILIZERS ARE PROHIBITED.
- FLATTEN WEEDS AND GRASS. REMOVE ANY NOXIOUS WEEDS.
- TILL SOIL ONLY IF NECESSARY. SEE SPECS.
- INSTALL ALL TREES.
- SPREAD A 1" MINIMUM LAYER OF COMPOST ON TOP OF SOIL. SEE SPEC.
- APPLY TWO LAYERS OF B FLUTE RECYCLED CARDBOARD ON ALL SOIL SURFACES. OVERLAP EDGES OF CARDBOARD 8". WET THE CARDBOARD TO KEEP IT IN PLACE
- SPREAD AN ADDITIONAL 1" COMPOST ON TOP OF CARDBOARD.
- APPLY 2" MULCH ON TOP OF CARDBOARD LAYER
- INSTALL 1 GALLON PLANTS THROUGH CARDBOARD. DO NOT ALLOW ANY SOIL TO REMAIN ON TOP OF CARDBOARD.

- INSTALL ALL DRIP LINES UNDERNEATH THE CARDBOARD/MULCH LAYER
- INSTALL 4" PLANTS AND PLUGS OR LINERS INTO MULCH AND COMPOST LAYERS (DO NOT PUNCH THROUGH CARDBOARD).
- DO NOT BURY ROOT CROWNS OF PLANTS IN MULCH.
- MAINTENANCE: REPLENISH MULCH AS NEEDED TO MAINTAIN SPECIFIED MULCH DEPTH

**NOTES:**

- PLACE SHEET MULCH ON ALL SOIL SURFACES.
- ALL CARDBOARD (100% RECYCLED B FLUTE CARDBOARD ROLLS) IS TO BE COVERED WITH A MINIMUM OF 6" MULCH.
- MULCH IS TO BE FROM LOCAL CHIPPED LANDSCAPE TRIMMINGS.
- WHERE SLOPE IS GREATER THAN 3:1 DO NOT USE CARDBOARD. APPLY ONLY A 2" LAYER OF COMPOST COVERED WITH 4" MULCH.

**1 SHRUB & PERENNIAL PLANTING**  
Scale: NTS

**2 SHEET MULCH SYSTEM**  
Scale: NTS

TRIANGULATED PLANT SPACING		
P (TRIANGLE)	R (ROW)	AREA (SQ FT)
4"	3 1/2"	.096
6"	5"	.22
8"	7"	.385
10"	9"	.60
12"	10 1/2"	.87
18"	1'-4"	1.95
24"	1'-9"	3.46
30"	2'-2"	5.42
36"	2'-7"	7.80
48"	3'-6"	13.84
60"	4'-4"	21.65
72"	5'-2"	31.20

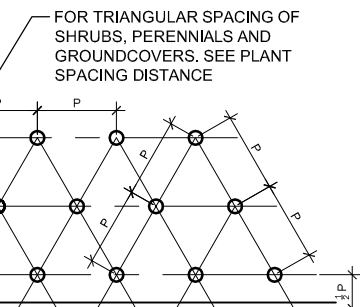

**3 ON-CENTER PLANT SPACING**  
NTS

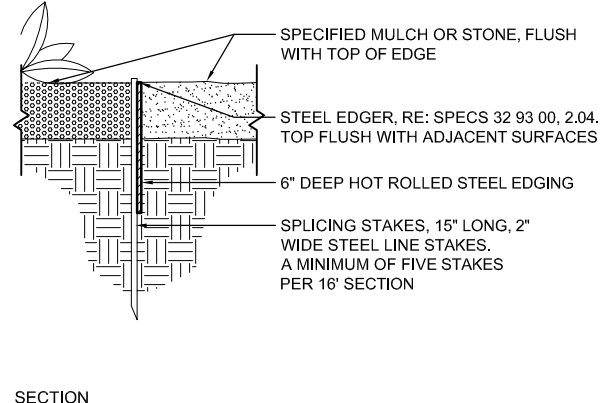

**4 STEEL EDGER**  
NTS

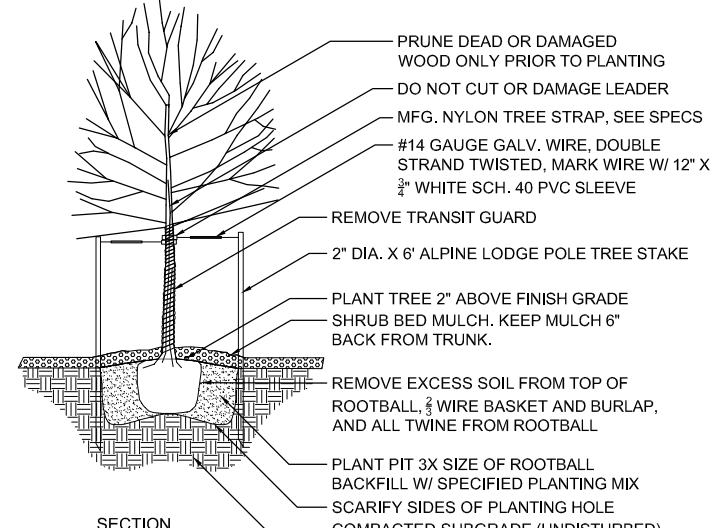

**5 DECIDUOUS TREE PLANTING**  
NTS

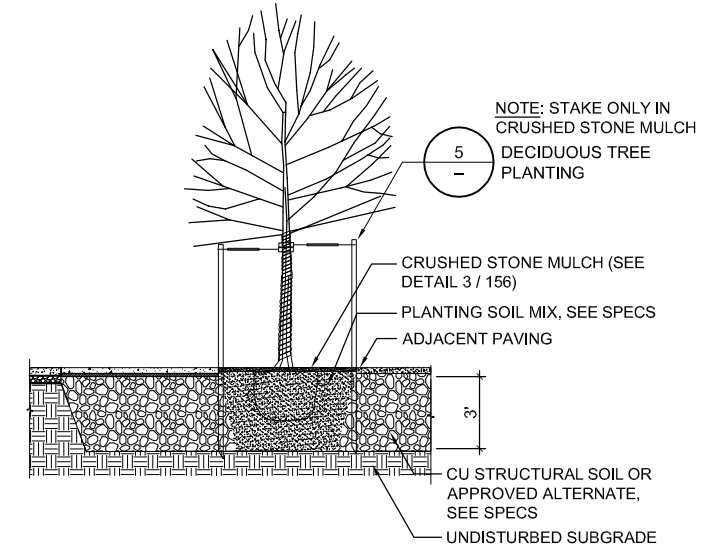

**6 TREE PLANTING AT STRUCTURAL SOIL**  
NTS

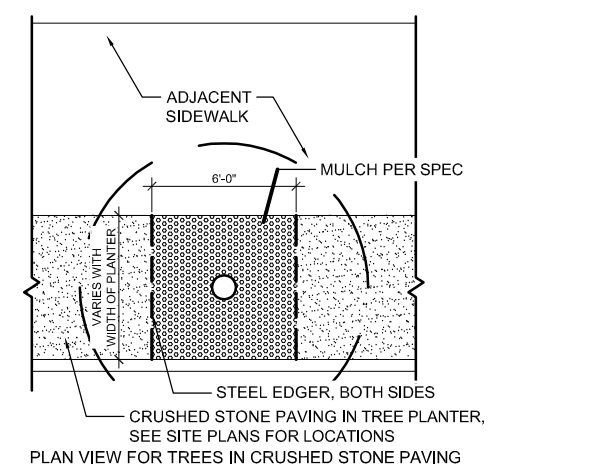

- PLACE STEEL EDGER PERPENDICULAR TO CURB 3' FROM CENTERLINE OF TREE TRUNK TO SEPARATE MULCH FROM CRUSHED STONE PAVING

**7 TREE PLANTING CRUSHED STONE MULCH**  
NTS

REV. NO.	DATE	DESCRIPTION	BY

MOORE IACOFANO GOLTSMAN, INC.  
317 LEXINGTON AVENUE, SUITE 2  
SAN ANTONIO, TEXAS, CA 78215  
TEL 210-600-9990  
www.mlgcom.com

**PAPE-DAWSON ENGINEERS**  
SAN ANTONIO | AUSTIN | HOUSTON | FORT WORTH | DALLAS  
2000 NW LOOP 410 | SAN ANTONIO, TX 78213 | 210.376.9000  
TEXAS ENGINEERING FIRM #170 | TEXAS SURVEYING FIRM #10028800

CITY OF SAN ANTONIO  
**PUBLIC WORKS DEPARTMENT**

DOLOROSA

**PLANTING DETAILS**

DESIGN	CHECKED	DRAWN	PROJECT NO.	SUBMITTAL	SHEET NO.
RD/AM	RD/AM	TM/RD	23-03763	70%	359

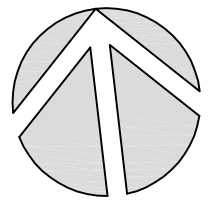
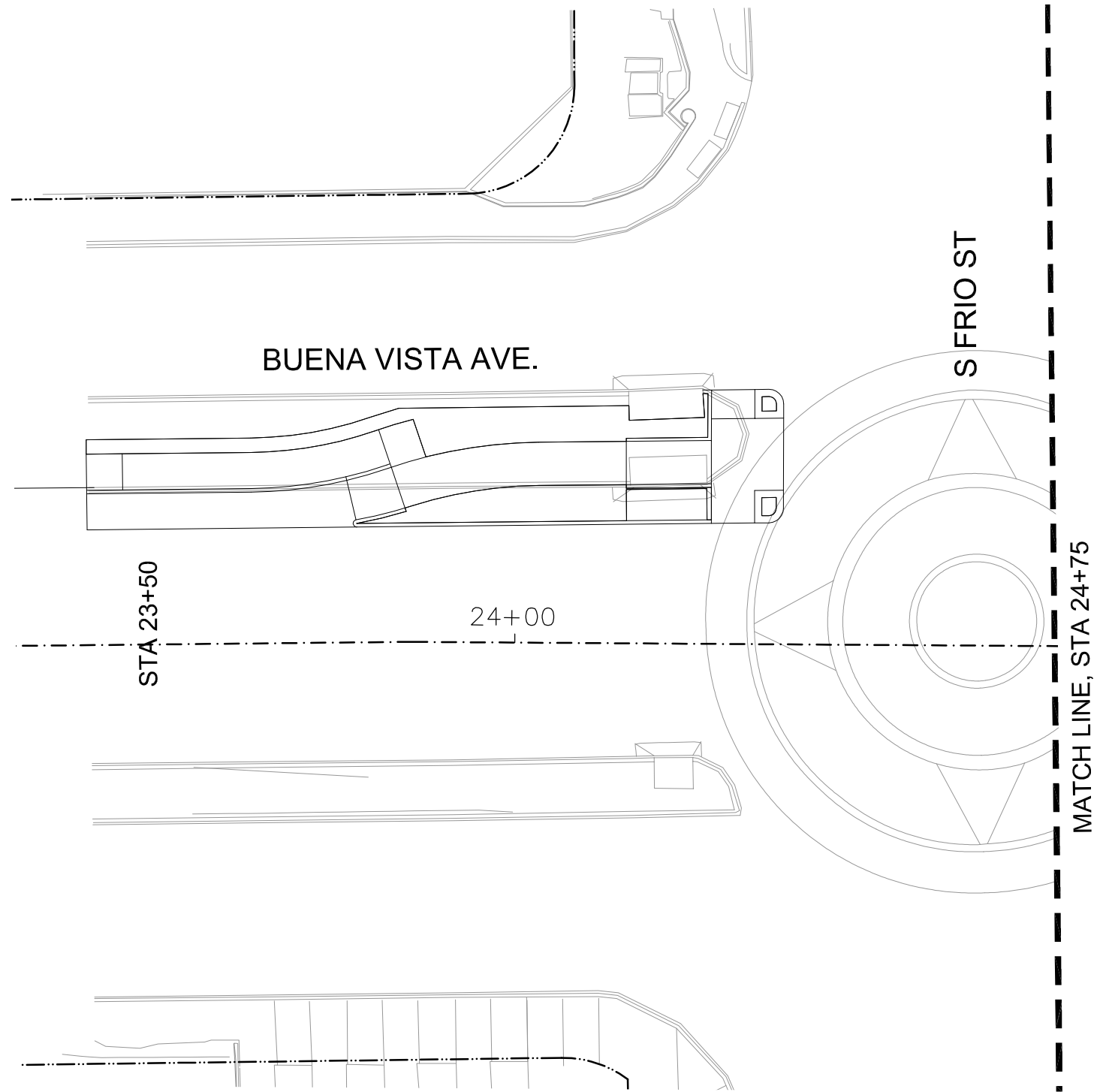

NORTH

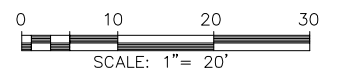

REV. NO.	DATE	DESCRIPTION	BY

**MOORE IACOFANO GOLTSMAN, INC.**  
 317 LEXINGTON AVENUE, SUITE 2  
 SAN ANTONIO, TEXAS, CA 78215  
 TEL 210-600-9990  
 www.migcom.com



SAN ANTONIO | AUSTIN | HOUSTON | FORT WORTH | DALLAS  
 2000 NW LOOP #10 | SAN ANTONIO, TX 78219 | 210.376.9000  
 TEXAS ENGINEERING FIRM #170 | TEXAS SURVEYING FIRM #10028600



CITY OF SAN ANTONIO  
**PUBLIC WORKS DEPARTMENT**

DOLOROSA  
**TREE PRESERVATION &  
 PLANTING PLAN**

STA 23+50 TO STA 24+75

SHEET 1 OF 16

## PLANT LEGEND



PLANT SYMBOLS, SEE PLANT SCHEDULE



CRUSHED STONE MULCH



EXISTING LANDSCAPE TO REMAIN  
(SEE PLANTING NOTES)



STRUCTURAL SOIL



(E) TREE TO BE PROTECTED WITH ROOT ZONE  
(SEE INVENTORY SHEET)



TREE TO BE REMOVED

————— RIGHT OF WAY

----- LIMIT OF WORK

----- MATCHLINE

DESIGN	CHECKED	DRAWN	PROJECT NO.	SUBMITTAL	SHEET NO.
RD/AM	RD/AM	TM/RD	23-03763	70%	360

COSA PM team will need to see a roll plot drawing or digital file with all utilities, trees, and light pole foundations. I need to see this before proceeding to 95% design. I cannot make comments on planting or illumination layouts without seeing how underground conflicts will impact what is proposed.

Where are structural soil dimensions and areas detailed? Need to see areas and quantities on sheets. Include quantity boxes with 95% design.

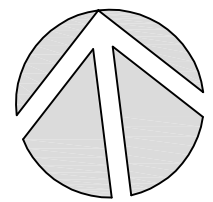
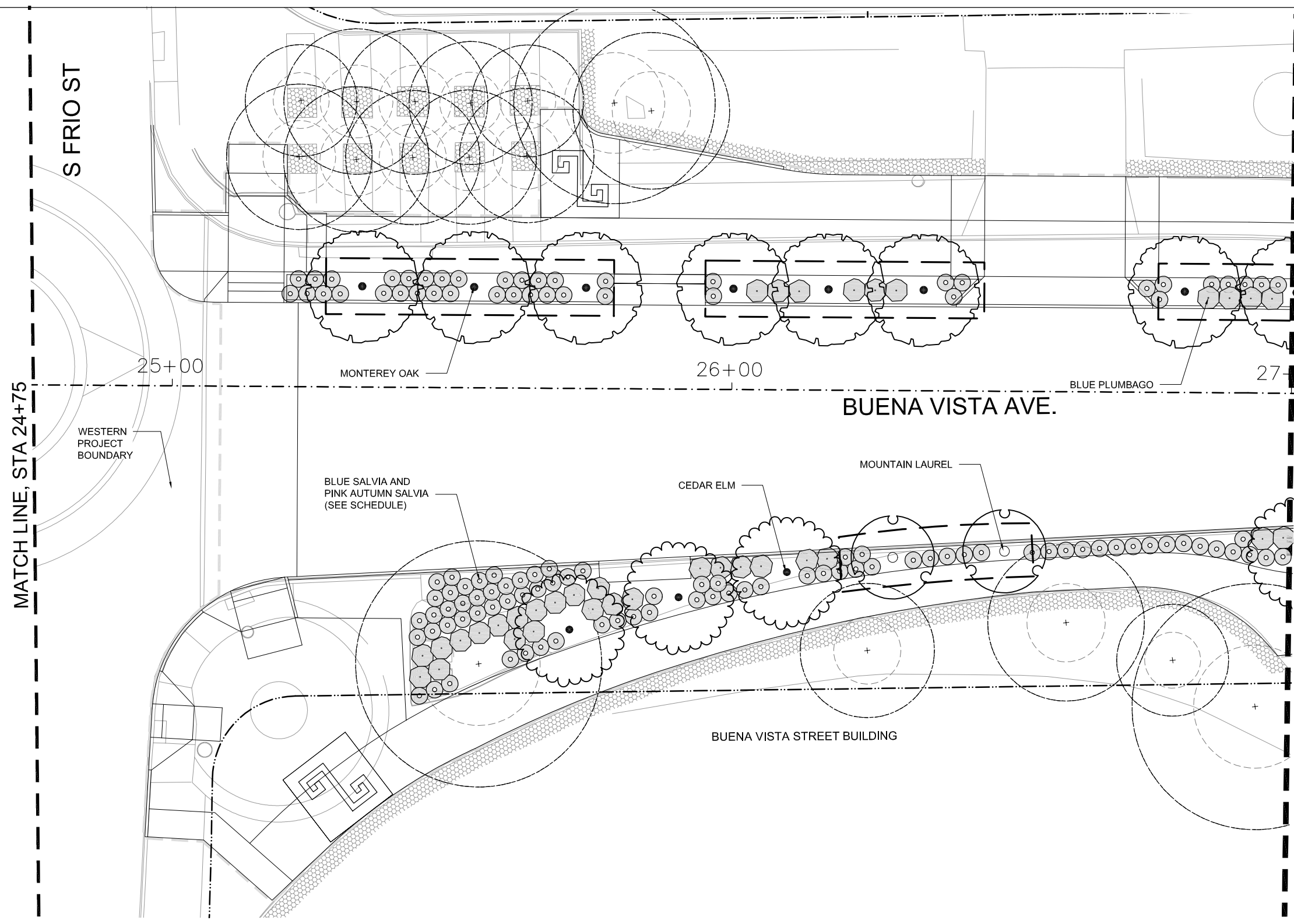

NORTH

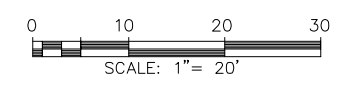

REV. NO.	DATE	DESCRIPTION	BY

**MOORE IACOFANO GOLTSMAN, INC.**  
 317 LEXINGTON AVENUE, SUITE 2  
 SAN ANTONIO, TEXAS, CA 78215  
 TEL 210-600-9990  
 www.migcom.com



SAN ANTONIO | AUSTIN | HOUSTON | FORT WORTH | DALLAS  
 2000 NW LOOP 410 | SAN ANTONIO, TX 78218 | 210.875.9000  
 TEXAS ENGINEERING FIRM #170 | TEXAS SURVEYING FIRM #10028800



DOLOROSA  
**TREE PRESERVATION & PLANTING PLAN**

STA 24+75 TO STA 27+00

SHEET 2 OF 16

### PLANT LEGEND

- PLANT SYMBOLS, SEE PLANT SCHEDULE
- CRUSHED STONE MULCH
- EXISTING LANDSCAPE TO REMAIN (SEE PLANTING NOTES)
- STRUCTURAL SOIL
- (E) TREE TO BE PROTECTED WITH ROOT ZONE (SEE INVENTORY SHEET)
- TREE TO BE REMOVED
- RIGHT OF WAY
- LIMIT OF WORK
- MATCHLINE

DESIGN	CHECKED	DRAWN	PROJECT NO.	SUBMITTAL	SHEET NO.
RD/AM	RD/AM	TM/RD	23-03763	70%	361

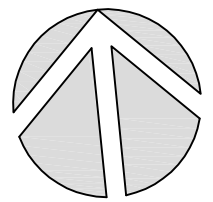
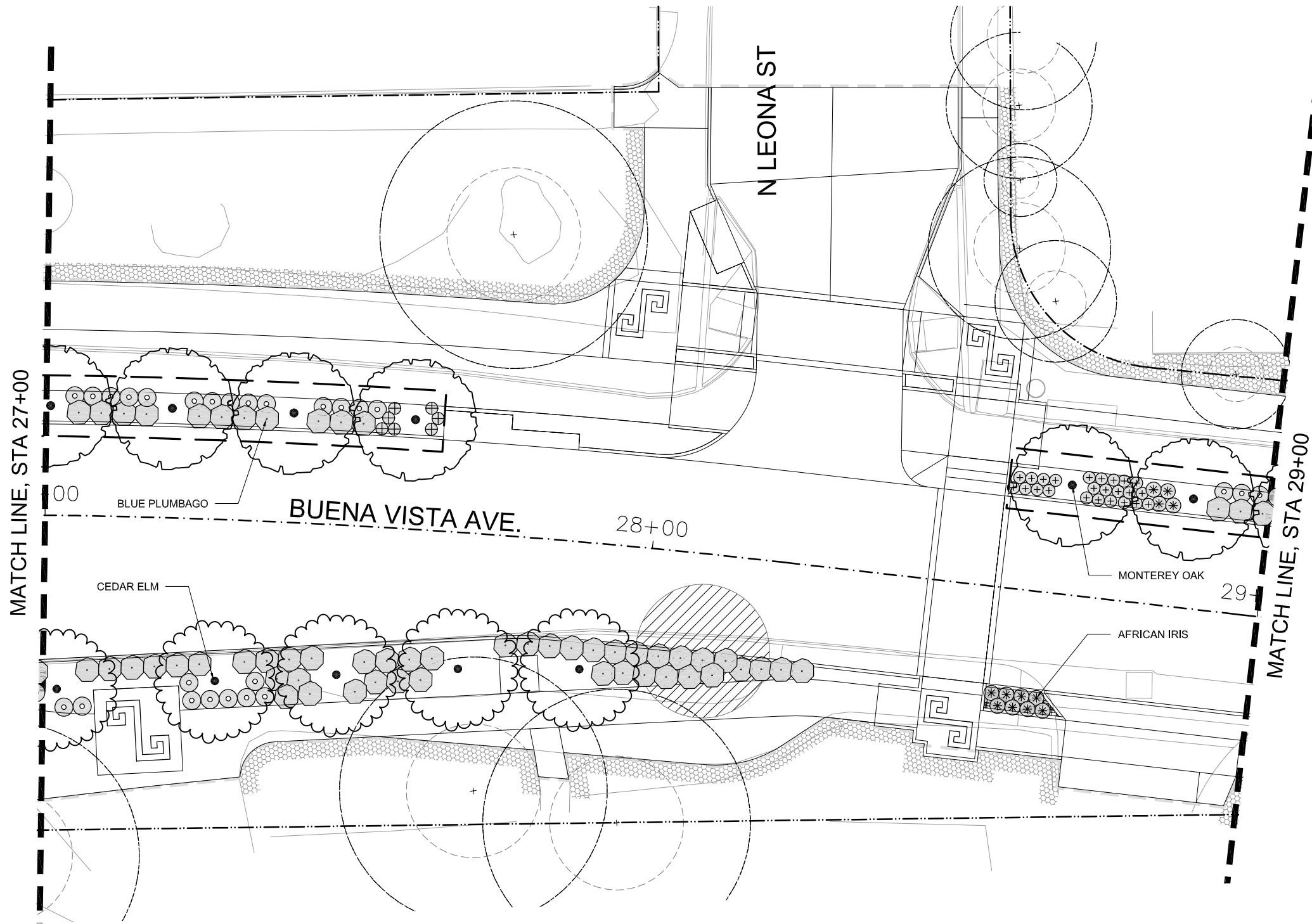

NORTH

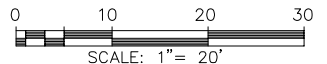

REV. NO.	DATE	DESCRIPTION	BY

**M I G** MOORE IACOFANO GOLTSMAN, INC.  
 317 LEXINGTON AVENUE, SUITE 2 TEL 210-600-9990  
 SAN ANTONIO, TEXAS, CA 78215 www.migcom.com



SAN ANTONIO | AUSTIN | HOUSTON | FORT WORTH | DALLAS  
 2000 NW LOOP 410 | SAN ANTONIO, TX 78218 | 210.875.9000  
 TEXAS ENGINEERING FIRM #170 | TEXAS SURVEYING FIRM #10028800



CITY OF SAN ANTONIO  
**PUBLIC WORKS DEPARTMENT**

DOLOROSA  
**TREE PRESERVATION & PLANTING PLAN**

STA 27+00 TO STA 29+00

SHEET 3 OF 16

**PLANT LEGEND**







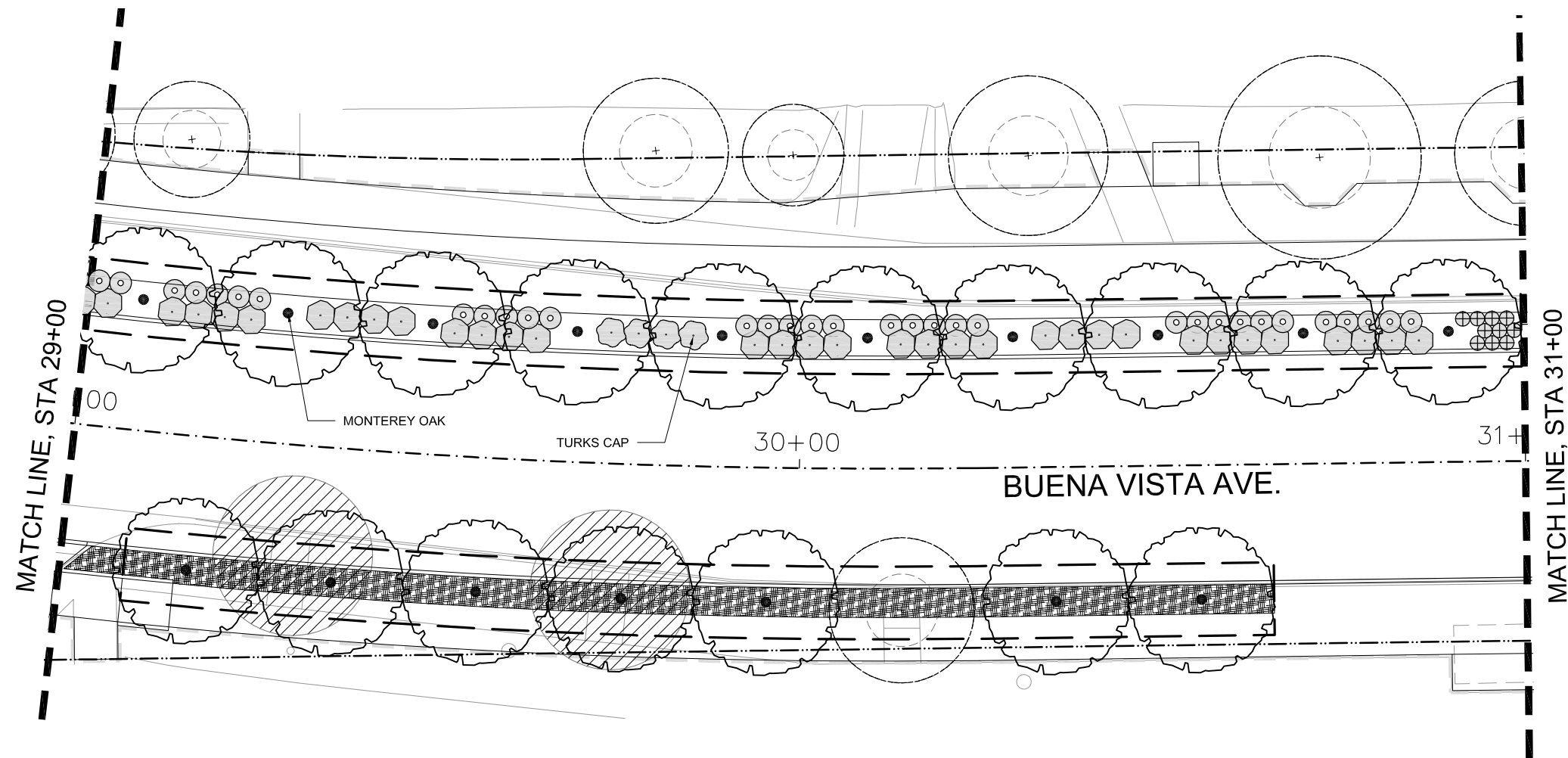

- PLANT SYMBOLS, SEE PLANT SCHEDULE
- (E) TREE TO BE PROTECTED WITH ROOT ZONE (SEE INVENTORY SHEET)
- RIGHT OF WAY
- CRUSHED STONE MULCH
- TREE TO BE REMOVED
- LIMIT OF WORK
- EXISTING LANDSCAPE TO REMAIN (SEE PLANTING NOTES)
- MATCHLINE
- STRUCTURAL SOIL

DESIGN	CHECKED	DRAWN	PROJECT NO.	SUBMITTAL	SHEET NO.
RD/AM	RD/AM	TM/RD	23-03763	70%	362

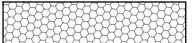
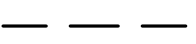

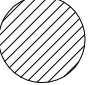

### PLANT LEGEND

- 
PLANT SYMBOLS, SEE PLANT SCHEDULE
- 
CRUSHED STONE MULCH
- 
EXISTING LANDSCAPE TO REMAIN (SEE PLANTING NOTES)
- 
STRUCTURAL SOIL
- 
(E) TREE TO BE PROTECTED WITH ROOT ZONE (SEE INVENTORY SHEET)
- 
TREE TO BE REMOVED
- 
RIGHT OF WAY
- 
LIMIT OF WORK
- 
MATCHLINE

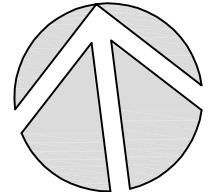

NORTH

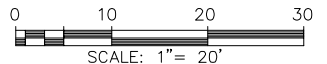

REV. NO.	DATE	DESCRIPTION	BY

MOORE IACOFANO GOLTSMAN, INC.  
 317 LEXINGTON AVENUE, SUITE 2 | TEL 210-600-9990  
 SAN ANTONIO, TEXAS, CA 78215 | www.migcom.com



SAN ANTONIO | AUSTIN | HOUSTON | FORT WORTH | DALLAS  
 2000 NW LOOP 410 | SAN ANTONIO, TX 78218 | 210.876.9000  
 TEXAS ENGINEERING FIRM #170 | TEXAS SURVEYING FIRM #10028800



CITY OF SAN ANTONIO  
**PUBLIC WORKS DEPARTMENT**

DOLOROSA

### TREE PRESERVATION & PLANTING PLAN

STA 29+00 TO STA 31+00

SHEET 4 OF 16

DESIGN	CHECKED	DRAWN	PROJECT NO.	SUBMITTAL	SHEET NO.
RD/AM	RD/AM	TM/RD	23-03763	70%	363

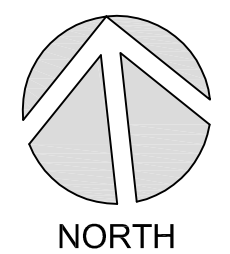
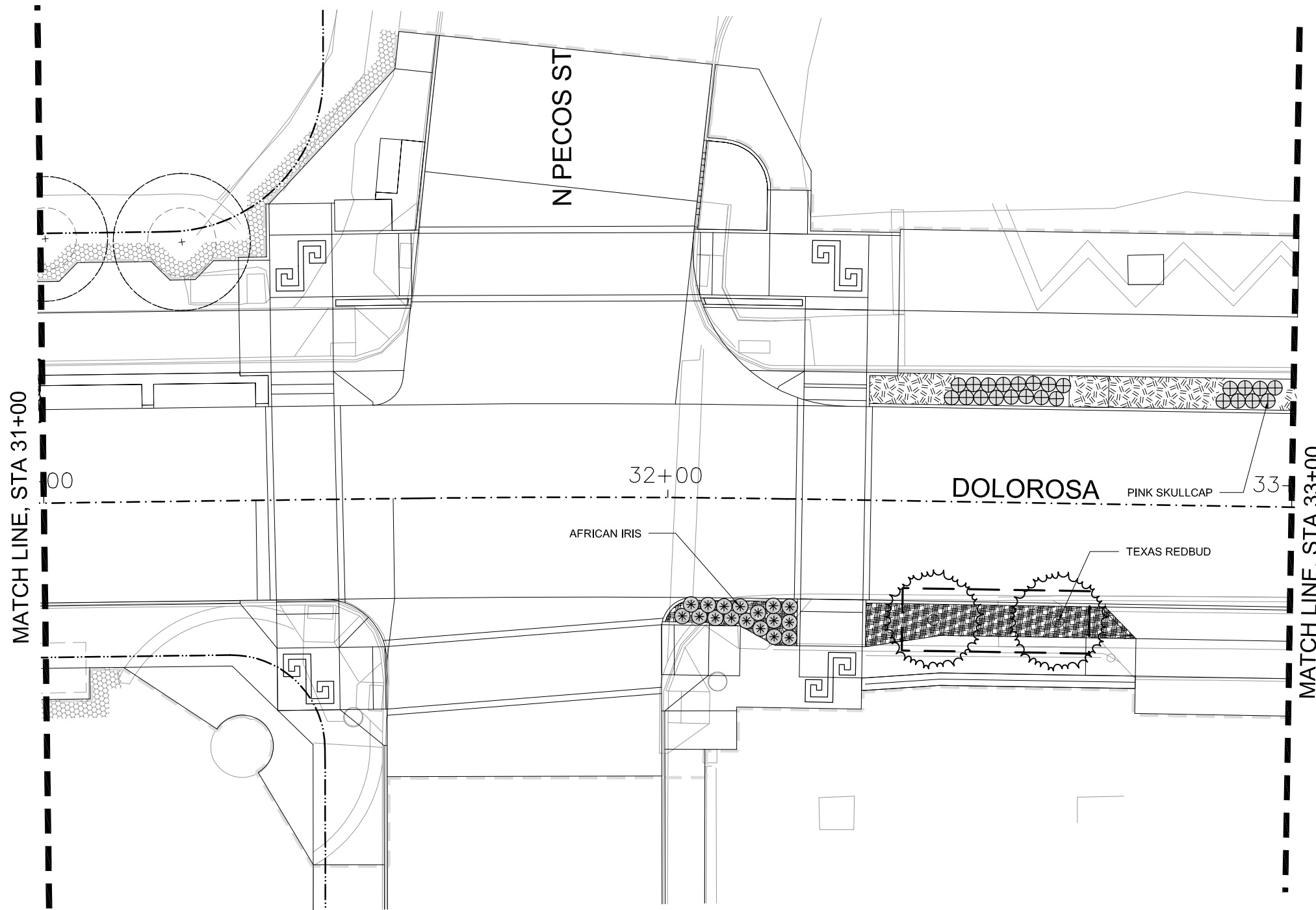

NORTH

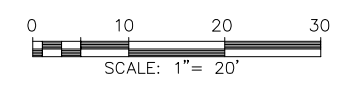

REV. NO.	DATE	DESCRIPTION	BY

MOORE IACOFANO GOLTSMAN, INC.  
 317 LEXINGTON AVENUE, SUITE 2 TEL 210-600-9990  
 SAN ANTONIO, TEXAS, CA 78215 www.migcom.com

**PAPE-DAWSON ENGINEERS**  
 SAN ANTONIO | AUSTIN | HOUSTON | FORT WORTH | DALLAS  
 2000 NW LOOP 410 | SAN ANTONIO, TX 78218 | 210.876.9000  
 TEXAS ENGINEERING FIRM #170 | TEXAS SURVEYING FIRM #10028800

CITY OF SAN ANTONIO  
**PUBLIC WORKS DEPARTMENT**

DOLOROSA  
**TREE PRESERVATION & PLANTING PLAN**

STA 31+00 TO STA 33+00

SHEET 5 OF 16

**PLANT LEGEND**

- |  |   |  |
|--|---|--|
| PLANT SYMBOLS, SEE PLANT SCHEDULE<br>CRUSHED STONE MULCH<br>EXISTING LANDSCAPE TO REMAIN (SEE PLANTING NOTES)<br>STRUCTURAL SOIL | (E) TREE TO BE PROTECTED WITH ROOT ZONE (SEE INVENTORY SHEET)<br>TREE TO BE REMOVED | RIGHT OF WAY<br>LIMIT OF WORK<br>MATCHLINE |
|--|---|--|

DESIGN	CHECKED	DRAWN	PROJECT NO.	SUBMITTAL	SHEET NO.
RD/AM	RD/AM	TM/RD	23-03763	70%	364

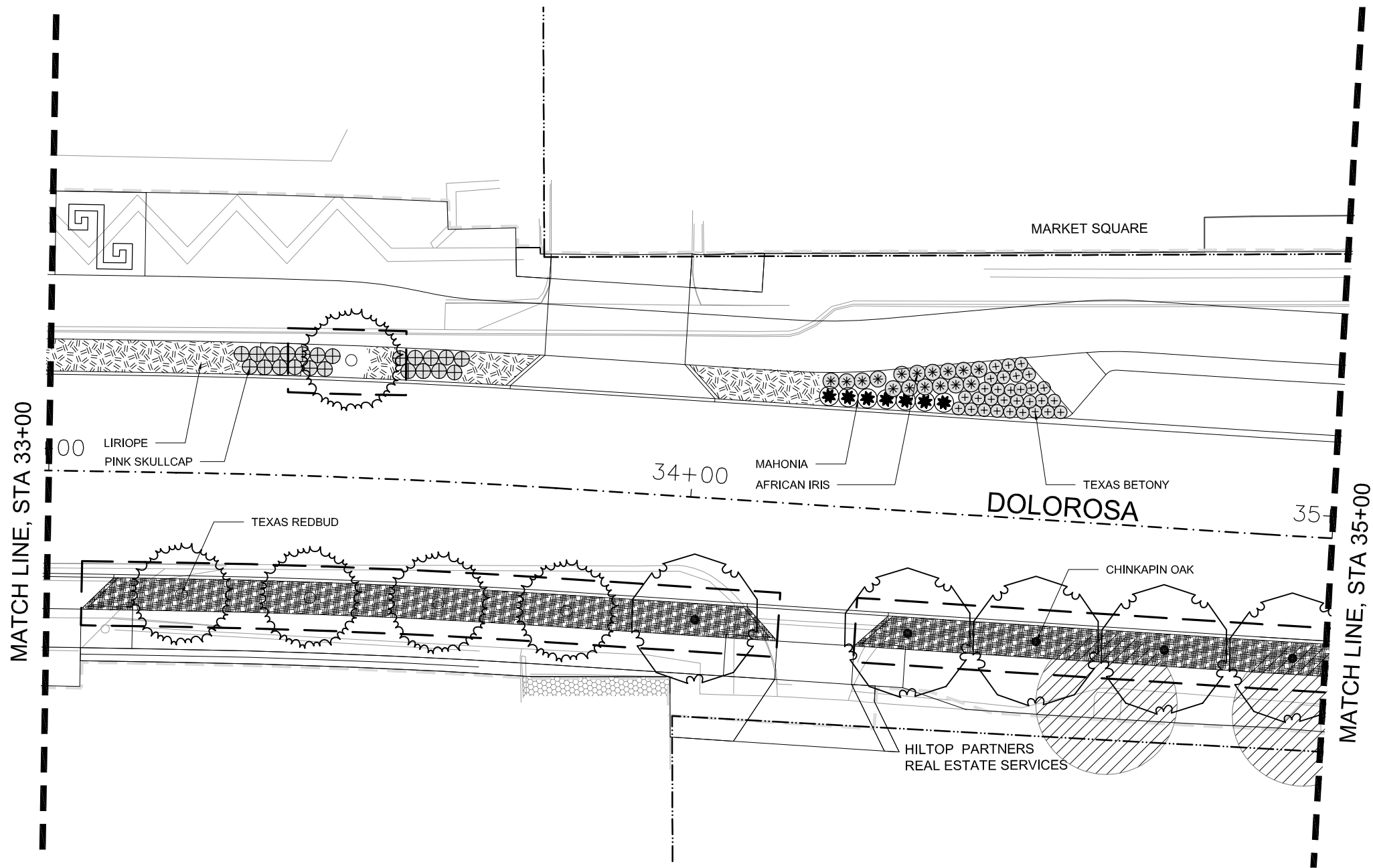

MATCH LINE, STA 33+00

MATCH LINE, STA 35+00

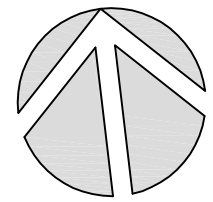

NORTH

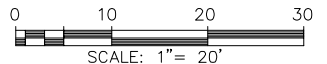

REV. NO.	DATE	DESCRIPTION	BY

**MOORE IACOFANO GOLTSMAN, INC.**  
 317 LEXINGTON AVENUE, SUITE 2  
 SAN ANTONIO, TEXAS, CA 78215  
 TEL 210-600-9990  
 www.migcom.com



**PAPE-DAWSON ENGINEERS**  
 SAN ANTONIO | AUSTIN | HOUSTON | FORT WORTH | DALLAS  
 2000 NW LOOP 410 | SAN ANTONIO, TX 78219 | 210.376.9000  
 TEXAS ENGINEERING FIRM #170 | TEXAS SURVEYING FIRM #10028600



CITY OF SAN ANTONIO  
**PUBLIC WORKS DEPARTMENT**

DOLOROSA  
**TREE PRESERVATION & PLANTING PLAN**

STA 33+00 TO STA 35+00

SHEET 6 OF 16

## PLANT LEGEND

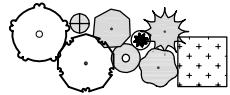

PLANT SYMBOLS, SEE PLANT SCHEDULE



CRUSHED STONE MULCH

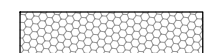

EXISTING LANDSCAPE TO REMAIN  
 (SEE PLANTING NOTES)

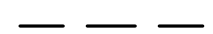

STRUCTURAL SOIL

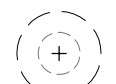

(E) TREE TO BE PROTECTED WITH ROOT ZONE  
 (SEE INVENTORY SHEET)

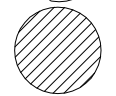

TREE TO BE REMOVED

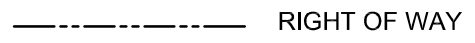

RIGHT OF WAY



LIMIT OF WORK



MATCHLINE

DESIGN	CHECKED	DRAWN	PROJECT NO.	SUBMITTAL	SHEET NO.
RD/AM	RD/AM	TM/RD	23-03763	70%	365

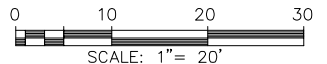
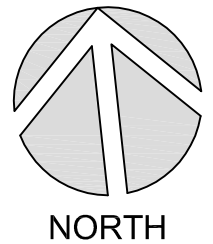
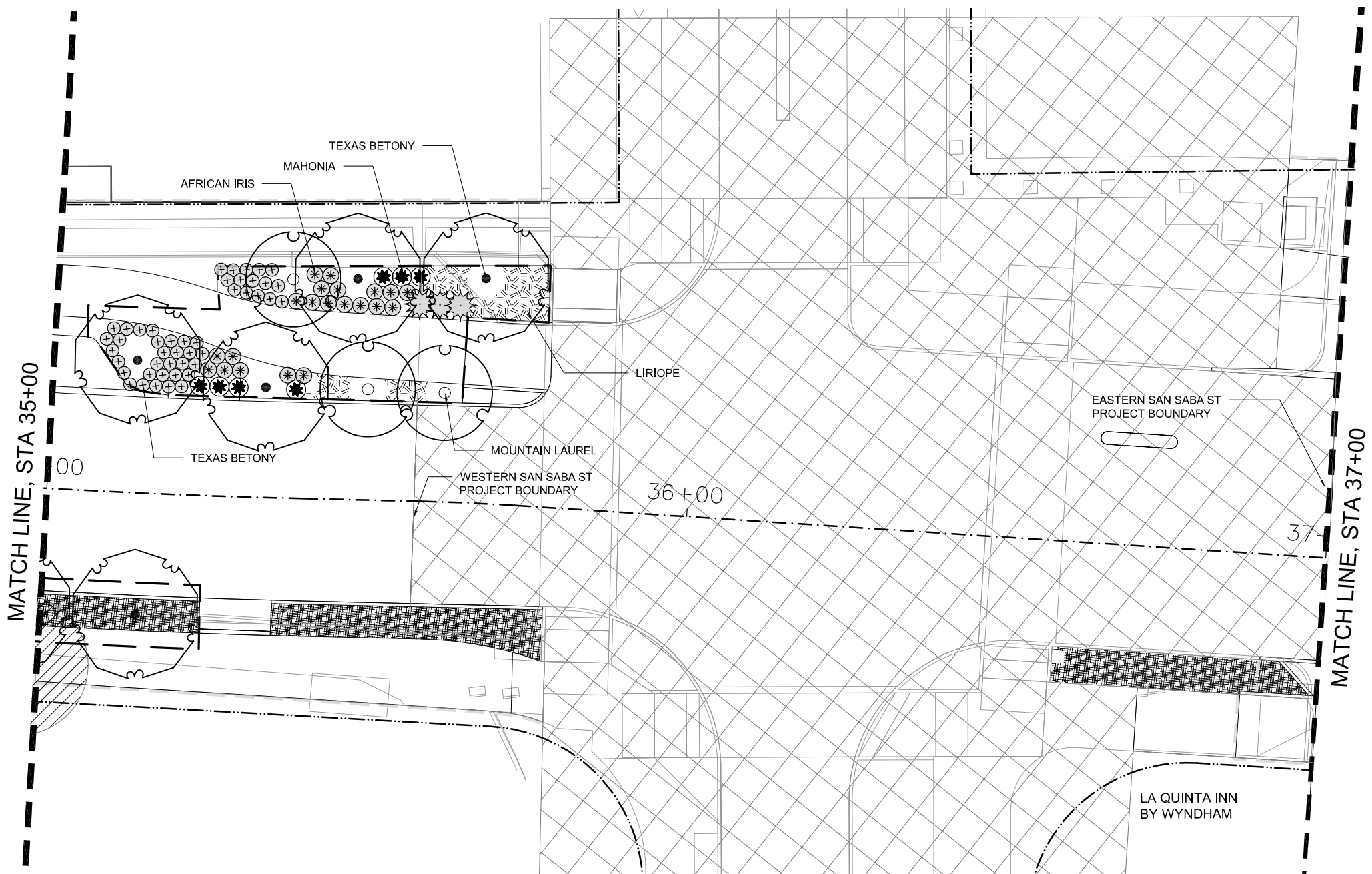

REV. NO.	DATE	DESCRIPTION	BY

**MOORE IACOFANO GOLTSMAN, INC.**  
 317 LEXINGTON AVENUE, SUITE 200  
 SAN ANTONIO, TEXAS, CA 78215  
 TEL 210-600-9990  
 www.migcom.com



SAN ANTONIO | AUSTIN | HOUSTON | FORT WORTH | DALLAS  
 2000 NW LOOP 410 | SAN ANTONIO, TX 78218 | 210.875.9000  
 TEXAS ENGINEERING FIRM #170 | TEXAS SURVEYING FIRM #10028800



CITY OF SAN ANTONIO  
**PUBLIC WORKS DEPARTMENT**

DOLOROSA

**TREE PRESERVATION & PLANTING PLAN**

STA 35+00 TO STA 37+00

SHEET 7 OF 16

**PLANT LEGEND**



PLANT SYMBOLS, SEE PLANT SCHEDULE



CRUSHED STONE MULCH

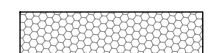

EXISTING LANDSCAPE TO REMAIN (SEE PLANTING NOTES)



STRUCTURAL SOIL

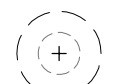

(E) TREE TO BE PROTECTED WITH ROOT ZONE (SEE INVENTORY SHEET)

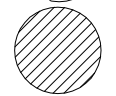

TREE TO BE REMOVED

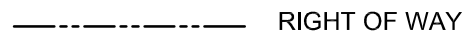

RIGHT OF WAY



LIMIT OF WORK



MATCHLINE

DESIGN	CHECKED	DRAWN	PROJECT NO.	SUBMITTAL	SHEET NO.
RD/AM	RD/AM	TM/RD	23-03763	70%	366

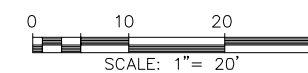
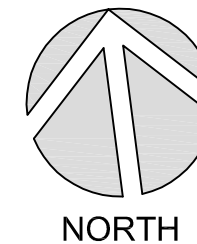
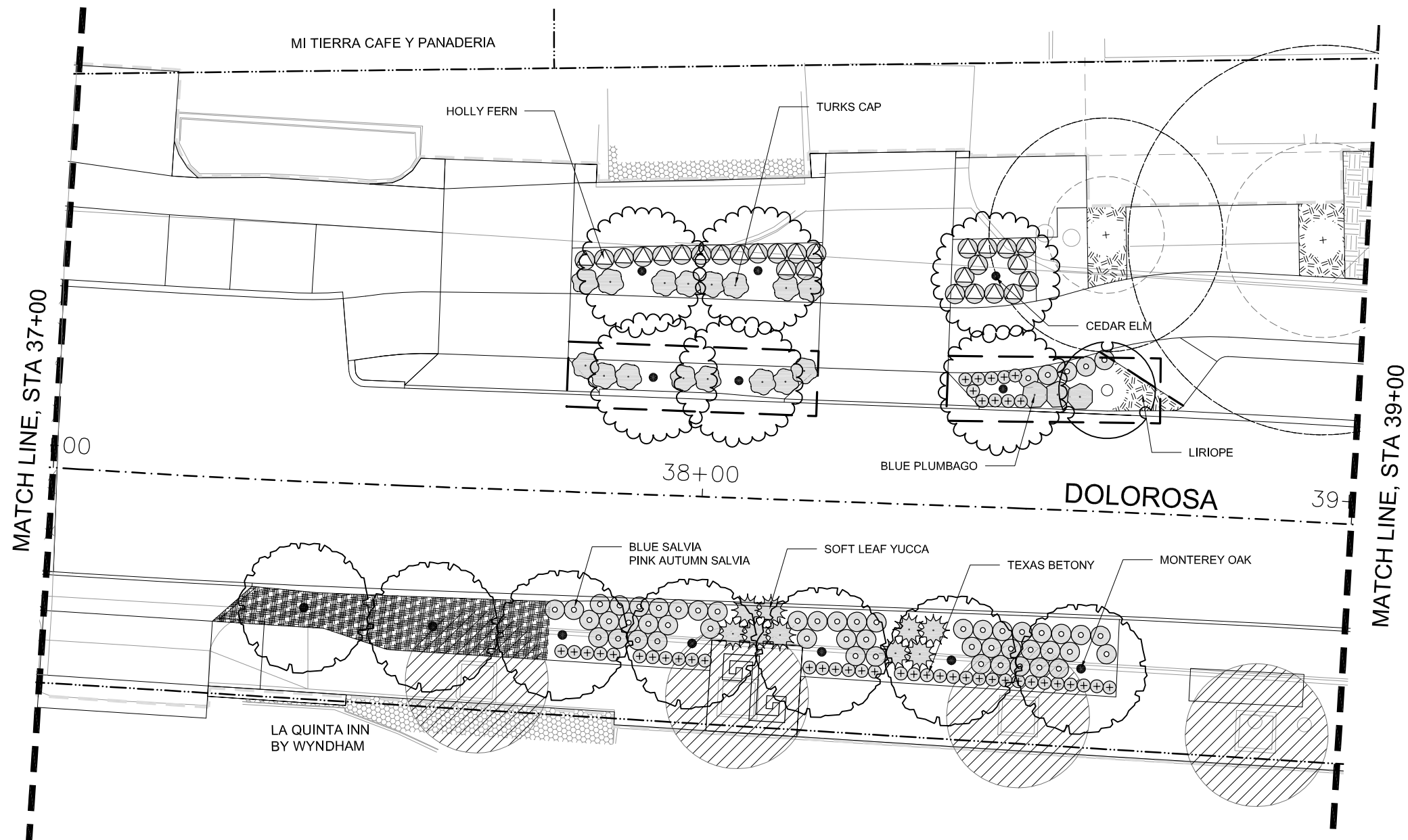

REV. NO.	DATE	DESCRIPTION	BY
<b>MOORE IACOFANO GOLTSMAN, INC.</b> <small>317 LEXINGTON AVENUE, SUITE 2   TEL 210-600-9990  SAN ANTONIO, TEXAS, CA 78215   www.migcom.com</small>			



SAN ANTONIO | AUSTIN | HOUSTON | FORT WORTH | DALLAS  
2000 NW LOOP 410 | SAN ANTONIO, TX 78218 | 210.875.9000  
TEXAS ENGINEERING FIRM #170 | TEXAS SURVEYING FIRM #10028800



CITY OF SAN ANTONIO  
**PUBLIC WORKS DEPARTMENT**

DOLOROSA  
**TREE PRESERVATION &  
PLANTING PLAN**

STA 37+00 TO STA 39+00

SHEET 8 OF 16

### PLANT LEGEND



PLANT SYMBOLS, SEE PLANT SCHEDULE



CRUSHED STONE MULCH



EXISTING LANDSCAPE TO REMAIN  
(SEE PLANTING NOTES)



STRUCTURAL SOIL



(E) TREE TO BE PROTECTED WITH ROOT ZONE  
(SEE INVENTORY SHEET)



TREE TO BE REMOVED

----- RIGHT OF WAY

- - - - - LIMIT OF WORK

----- MATCHLINE

DESIGN	CHECKED	DRAWN	PROJECT NO.	SUBMITTAL	SHEET NO.
RD/AM	RD/AM	TM/RD	23-03763	70%	367

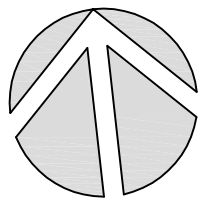
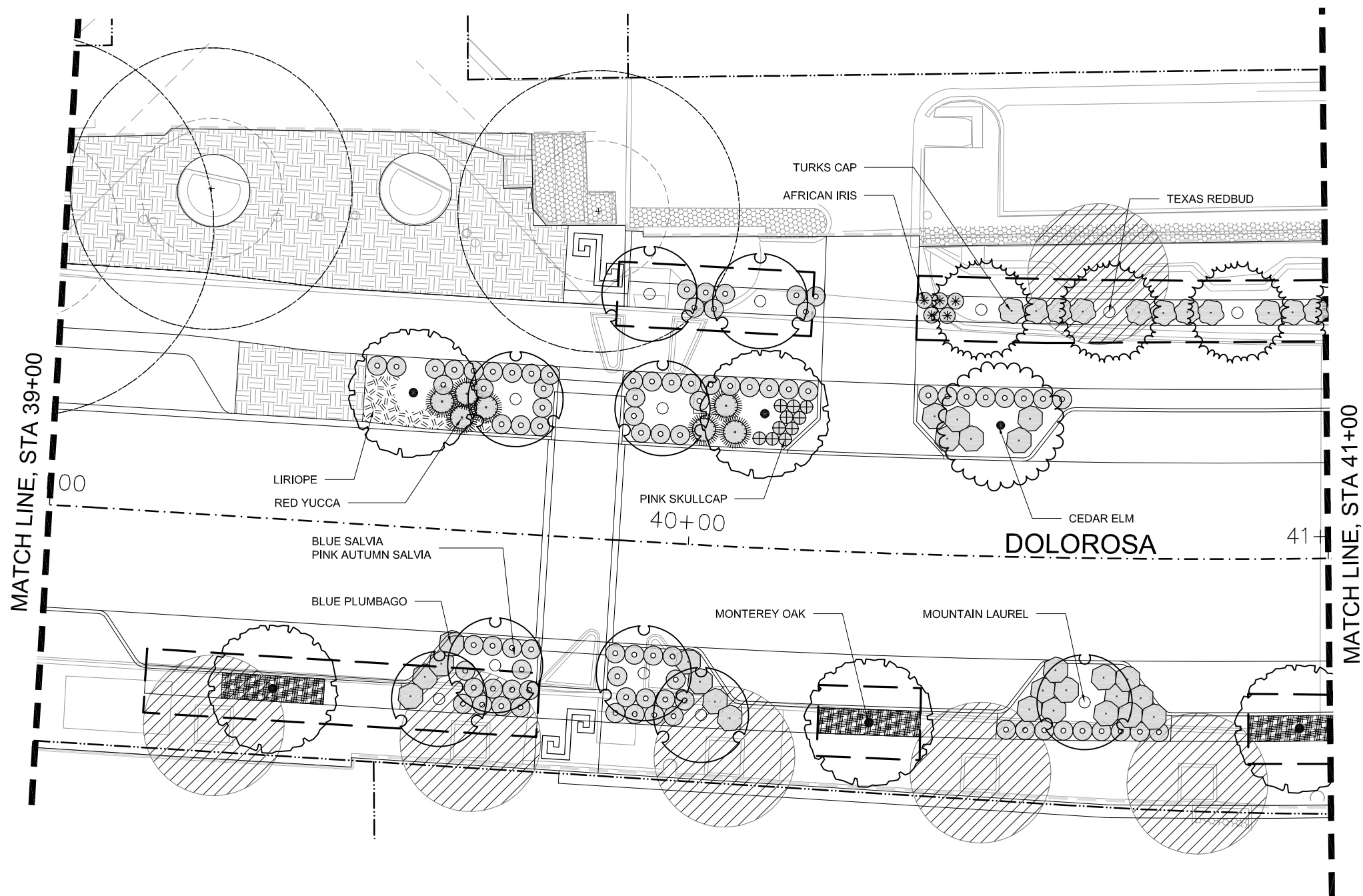

NORTH

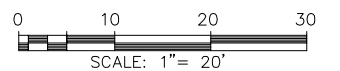

REV. NO.	DATE	DESCRIPTION	BY

**MOORE IACOFANO GOLTSMAN, INC.**  
 317 LEXINGTON AVENUE, SUITE 2 | TEL 210-600-9990  
 SAN ANTONIO, TEXAS, CA 78215 | www.migcom.com



**PAPE-DAWSON ENGINEERS**  
 SAN ANTONIO | AUSTIN | HOUSTON | FORT WORTH | DALLAS  
 2000 NW LOOP 410 | SAN ANTONIO, TX 78218 | 210.875.9000  
 TEXAS ENGINEERING FIRM #170 | TEXAS SURVEYING FIRM #10028800



CITY OF SAN ANTONIO  
**PUBLIC WORKS DEPARTMENT**

DOLOROSA  
**TREE PRESERVATION & PLANTING PLAN**

STA 39+00 TO STA 41+00

SHEET 9 OF 16

### PLANT LEGEND



PLANT SYMBOLS, SEE PLANT SCHEDULE



CRUSHED STONE MULCH

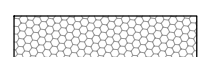

EXISTING LANDSCAPE TO REMAIN (SEE PLANTING NOTES)

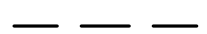

STRUCTURAL SOIL



(E) TREE TO BE PROTECTED WITH ROOT ZONE (SEE INVENTORY SHEET)



TREE TO BE REMOVED

————— RIGHT OF WAY





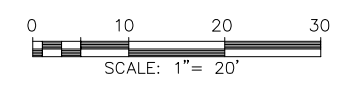
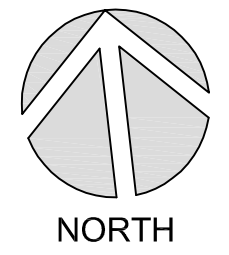
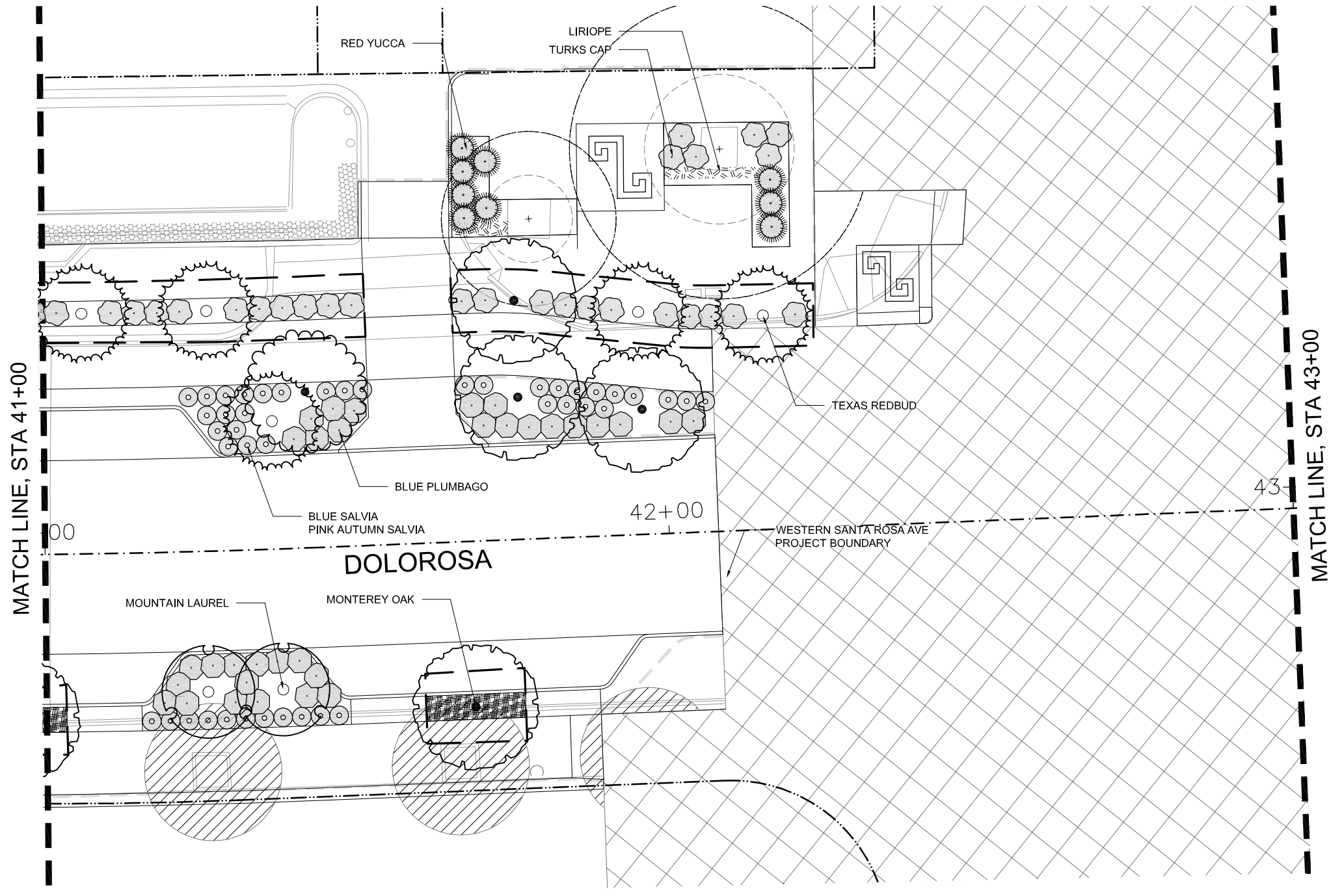

----- LIMIT OF WORK

————— MATCHLINE

DESIGN	CHECKED	DRAWN	PROJECT NO.	SUBMITTAL	SHEET NO.
RD/AM	RD/AM	TM/RD	23-03763	70%	368

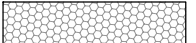
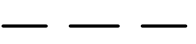

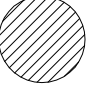
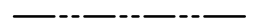
### PLANT LEGEND

- 
PLANT SYMBOLS, SEE PLANT SCHEDULE
- 
CRUSHED STONE MULCH
- 
EXISTING LANDSCAPE TO REMAIN (SEE PLANTING NOTES)
- 
STRUCTURAL SOIL
- 
(E) TREE TO BE PROTECTED WITH ROOT ZONE (SEE INVENTORY SHEET)
- 
TREE TO BE REMOVED
- 
RIGHT OF WAY
- 
LIMIT OF WORK
- 
MATCHLINE

REV. NO.	DATE	DESCRIPTION	BY

**MOORE IACOFANO GOLTSMAN, INC.**  
 317 LEXINGTON AVENUE, SUITE 2    TEL 210-600-9990  
 SAN ANTONIO, TEXAS, CA 78215    www.migcom.com

**PAPE-DAWSON ENGINEERS**

SAN ANTONIO | AUSTIN | HOUSTON | FORT WORTH | DALLAS  
 2000 NW LOOP 410 | SAN ANTONIO, TX 78219 | 210.376.9000  
 TEXAS ENGINEERING FIRM #170 | TEXAS SURVEYING FIRM #10028600

CITY OF SAN ANTONIO  
**PUBLIC WORKS DEPARTMENT**

DOLOROSA  
 TREE PRESERVATION &  
 PLANTING PLAN

STA 41+00 TO STA 43+00    SHEET 10 OF 16

DESIGN	CHECKED	DRAWN	PROJECT NO.	SUBMITTAL	SHEET NO.
RD/AM	RD/AM	TM/RD	23-03763	70%	369

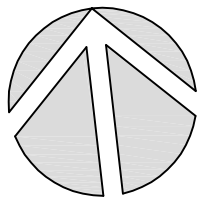
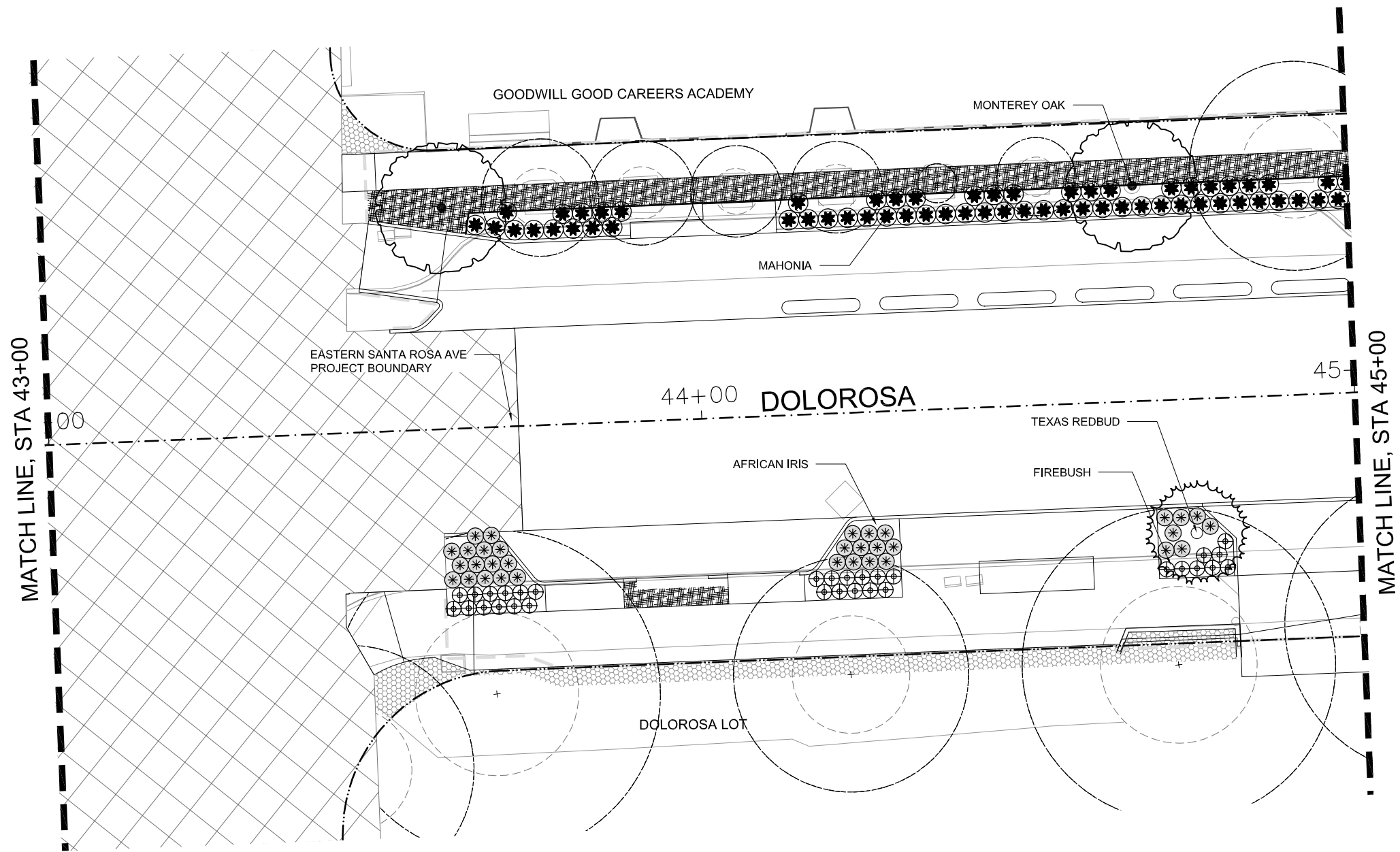

NORTH

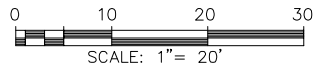

REV. NO.	DATE	DESCRIPTION	BY

**MOORE IACOFANO GOLTSMAN, INC.**  
 317 LEXINGTON AVENUE, SUITE 2  
 SAN ANTONIO, TEXAS, CA 78215  
 TEL 210-600-9990  
 www.migcom.com



SAN ANTONIO | AUSTIN | HOUSTON | FORT WORTH | DALLAS  
 2000 NW LOOP 410 | SAN ANTONIO, TX 78219 | 210.376.9000  
 TEXAS ENGINEERING FIRM #170 | TEXAS SURVEYING FIRM #10028600



CITY OF SAN ANTONIO  
**PUBLIC WORKS DEPARTMENT**

DOLOROSA  
**TREE PRESERVATION &  
 PLANTING PLAN**

STA 43+00 TO STA 45+00

SHEET 11 OF 16

### PLANT LEGEND



PLANT SYMBOLS, SEE PLANT SCHEDULE



CRUSHED STONE MULCH



EXISTING LANDSCAPE TO REMAIN  
(SEE PLANTING NOTES)



STRUCTURAL SOIL

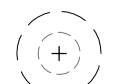

(E) TREE TO BE PROTECTED WITH ROOT ZONE  
(SEE INVENTORY SHEET)

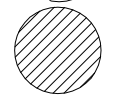

TREE TO BE REMOVED

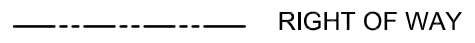

RIGHT OF WAY



LIMIT OF WORK



MATCHLINE

DESIGN	CHECKED	DRAWN	PROJECT NO.	SUBMITTAL	SHEET NO.
RD/AM	RD/AM	TM/RD	23-03763	70%	370



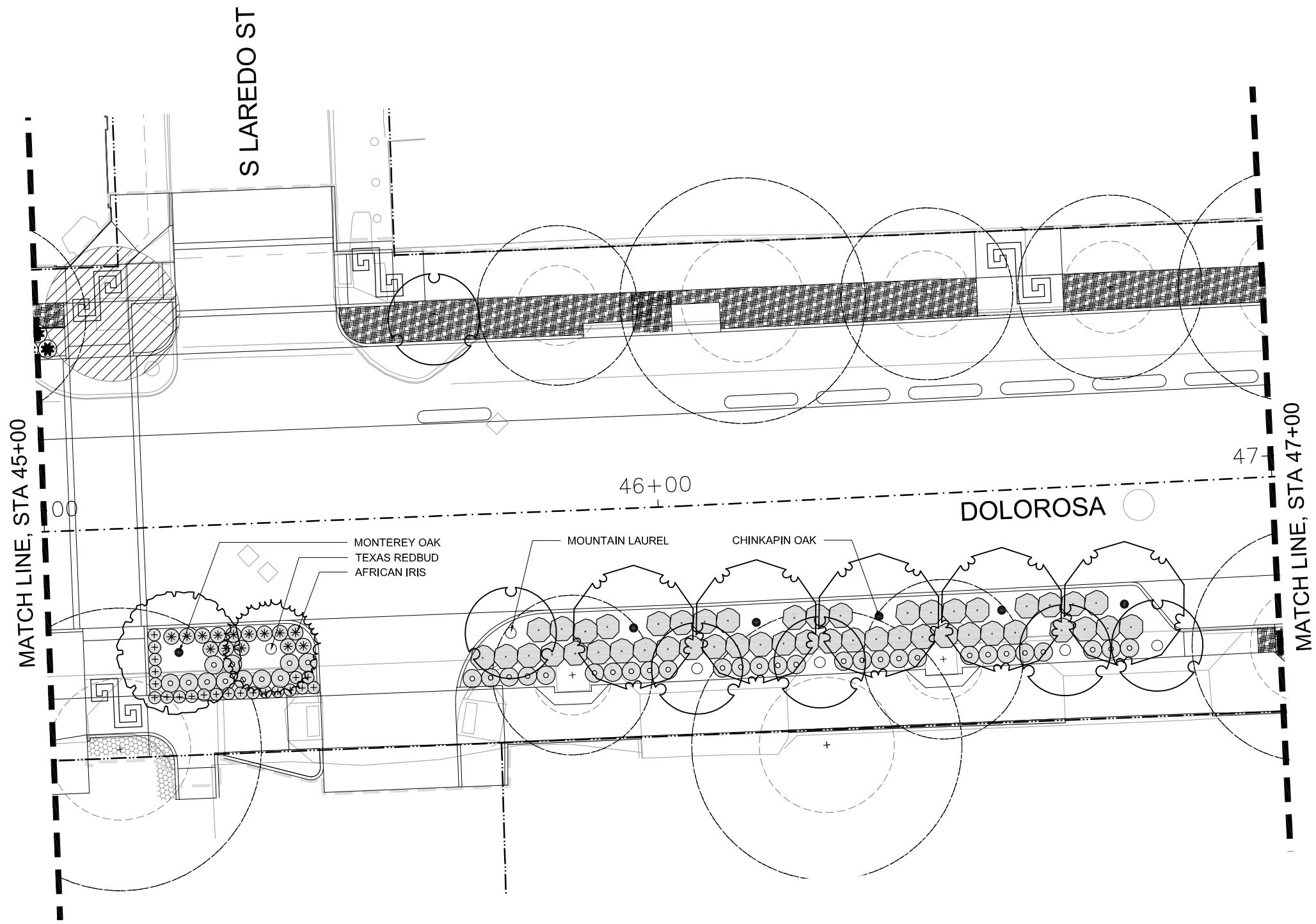



### PLANT LEGEND

- 

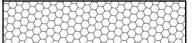
PLANT SYMBOLS, SEE PLANT SCHEDULE
- 

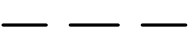
CRUSHED STONE MULCH
- 

EXISTING LANDSCAPE TO REMAIN (SEE PLANTING NOTES)
- 

STRUCTURAL SOIL
- 

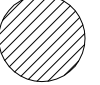
(E) TREE TO BE PROTECTED WITH ROOT ZONE (SEE INVENTORY SHEET)
- 

TREE TO BE REMOVED
- 

RIGHT OF WAY
- 

LIMIT OF WORK
- 

MATCHLINE

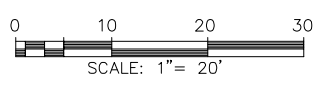
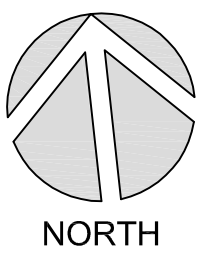

REV. NO.	DATE	DESCRIPTION	BY

MOORE IACOFANO GOLTSMAN, INC.  
 317 LEXINGTON AVENUE, SUITE 2 | TEL 210-600-9990  
 SAN ANTONIO, TEXAS, CA 78215 | www.migcom.com

**PAPE-DAWSON ENGINEERS**

SAN ANTONIO | AUSTIN | HOUSTON | FORT WORTH | DALLAS  
 2000 NW LOOP 410 | SAN ANTONIO, TX 78218 | 210.875.9000  
 TEXAS ENGINEERING FIRM #170 | TEXAS SURVEYING FIRM #10028800

**CITY OF SAN ANTONIO**  
**PUBLIC WORKS DEPARTMENT**

DOLOROSA  
 TREE PRESERVATION &  
 PLANTING PLAN

STA 45+00 TO STA 47+00

SHEET 12 OF 16

DESIGN	CHECKED	DRAWN	PROJECT NO.	SUBMITTAL	SHEET NO.
RD/AM	RD/AM	TM/RD	23-03763	70%	371

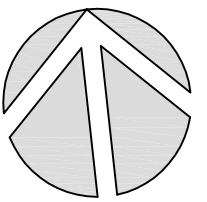
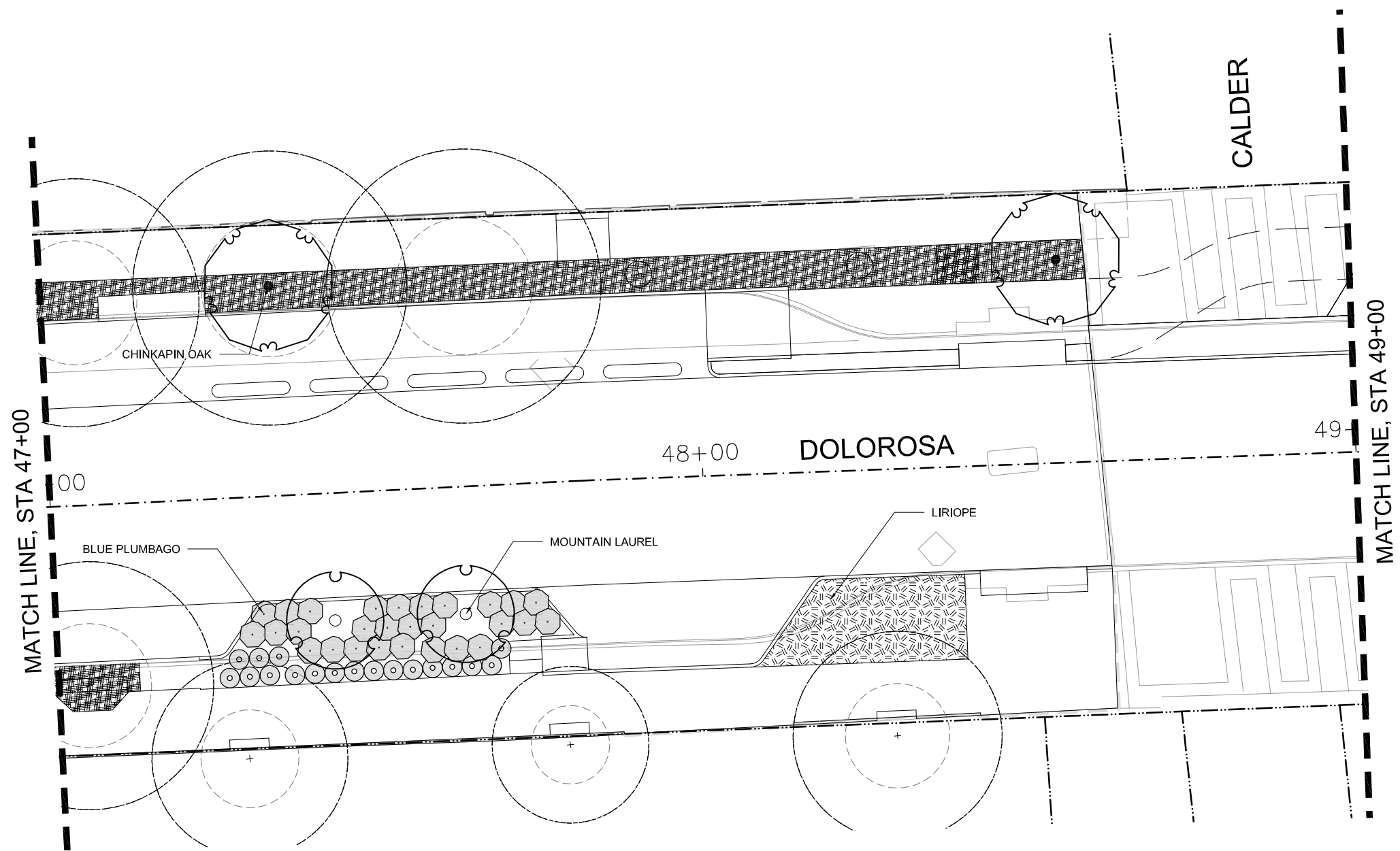

NORTH

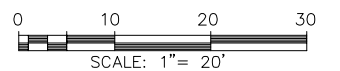

REV. NO.	DATE	DESCRIPTION	BY

**MOORE IACOFANO GOLTSMAN, INC.**  
 317 LEXINGTON AVENUE, SUITE 2 | TEL 210-600-9990  
 SAN ANTONIO, TEXAS, CA 78215 | www.migcom.com



SAN ANTONIO | AUSTIN | HOUSTON | FORT WORTH | DALLAS  
 2000 NW LOOP 410 | SAN ANTONIO, TX 78218 | 210.876.9000  
 TEXAS ENGINEERING FIRM #170 | TEXAS SURVEYING FIRM #10028800



CITY OF SAN ANTONIO  
**PUBLIC WORKS DEPARTMENT**

DOLOROSA  
**TREE PRESERVATION &  
 PLANTING PLAN**

STA 47+00 TO STA 49+00

SHEET 13 OF 16

## PLANT LEGEND



PLANT SYMBOLS, SEE PLANT SCHEDULE



CRUSHED STONE MULCH

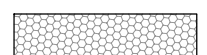

EXISTING LANDSCAPE TO REMAIN  
(SEE PLANTING NOTES)



STRUCTURAL SOIL



(E) TREE TO BE PROTECTED WITH ROOT ZONE  
(SEE INVENTORY SHEET)



TREE TO BE REMOVED

————— RIGHT OF WAY

- - - - - LIMIT OF WORK

————— MATCHLINE

DESIGN	CHECKED	DRAWN	PROJECT NO.	SUBMITTAL	SHEET NO.
RD/AM	RD/AM	TM/RD	23-03763	70%	372

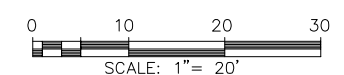
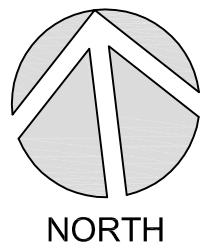
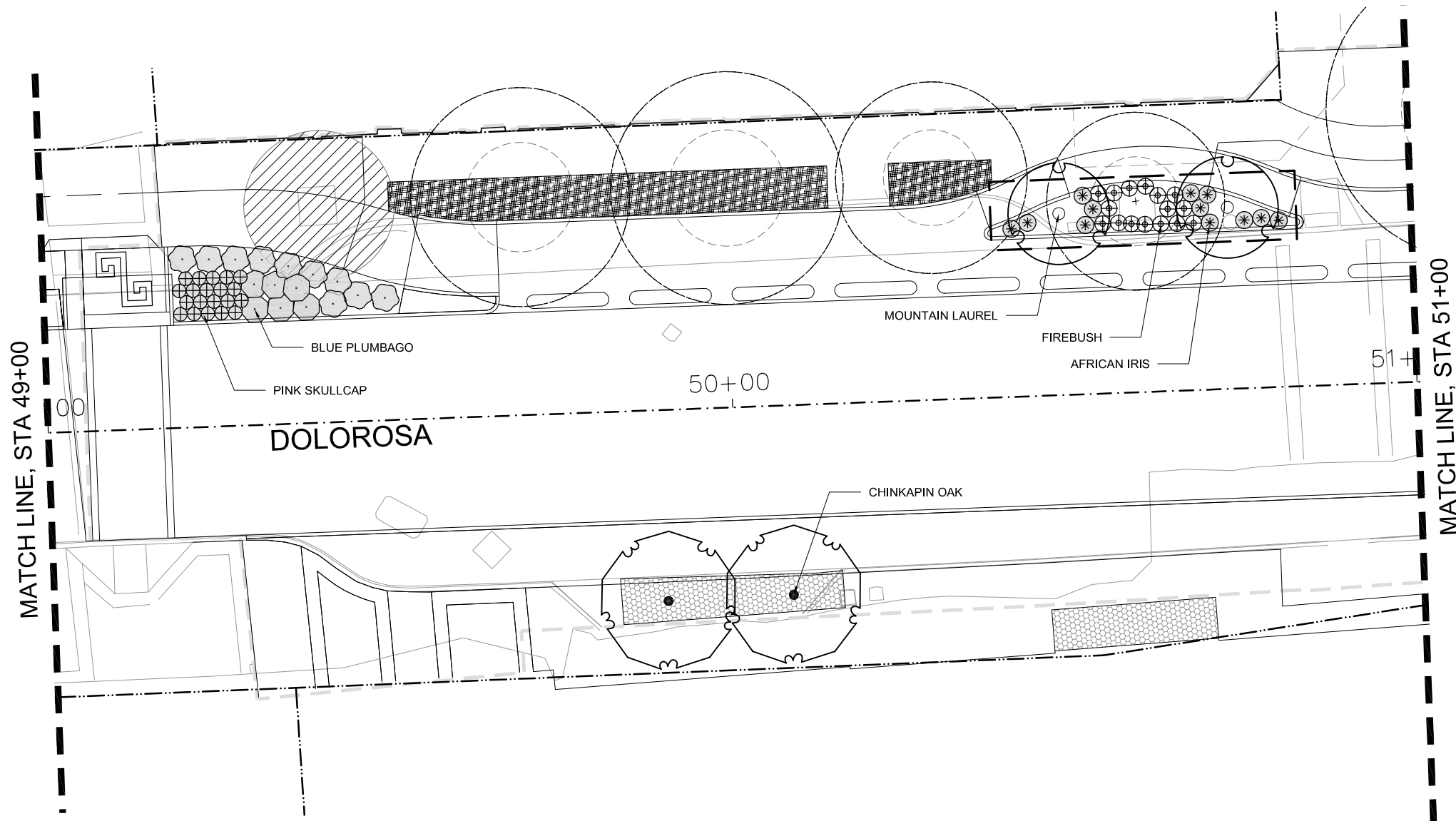

REV. NO.	DATE	DESCRIPTION	BY

**MOORE IACOFANO GOLTSMAN, INC.**  
 317 LEXINGTON AVENUE, SUITE 2 | TEL 210-600-9990  
 SAN ANTONIO, TEXAS, CA 78215 | www.migcom.com



SAN ANTONIO | AUSTIN | HOUSTON | FORT WORTH | DALLAS  
 2000 NW LOOP 410 | SAN ANTONIO, TX 78218 | 210.876.9000  
 TEXAS ENGINEERING FIRM #170 | TEXAS SURVEYING FIRM #10028800



CITY OF SAN ANTONIO  
**PUBLIC WORKS DEPARTMENT**

DOLOROSA  
**TREE PRESERVATION &  
 PLANTING PLAN**

STA 49+00 TO STA 51+00

SHEET 14 OF 16

## PLANT LEGEND

- |  |   |  |   |  |               |
|--|---|--|---|--|---------------|
|  | PLANT SYMBOLS, SEE PLANT SCHEDULE                 |  | (E) TREE TO BE PROTECTED WITH ROOT ZONE (SEE INVENTORY SHEET) |  | RIGHT OF WAY  |
|  | CRUSHED STONE MULCH                               |  | TREE TO BE REMOVED  |  | LIMIT OF WORK |
|  | EXISTING LANDSCAPE TO REMAIN (SEE PLANTING NOTES) |  |   |  | MATCHLINE     |
|  | STRUCTURAL SOIL                                   |  |   |  |               |

DESIGN	CHECKED	DRAWN	PROJECT NO.	SUBMITTAL	SHEET NO.
RD/AM	RD/AM	TM/RD	23-03763	70%	373

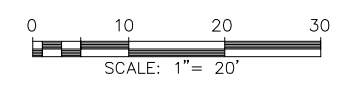
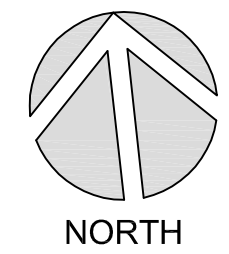
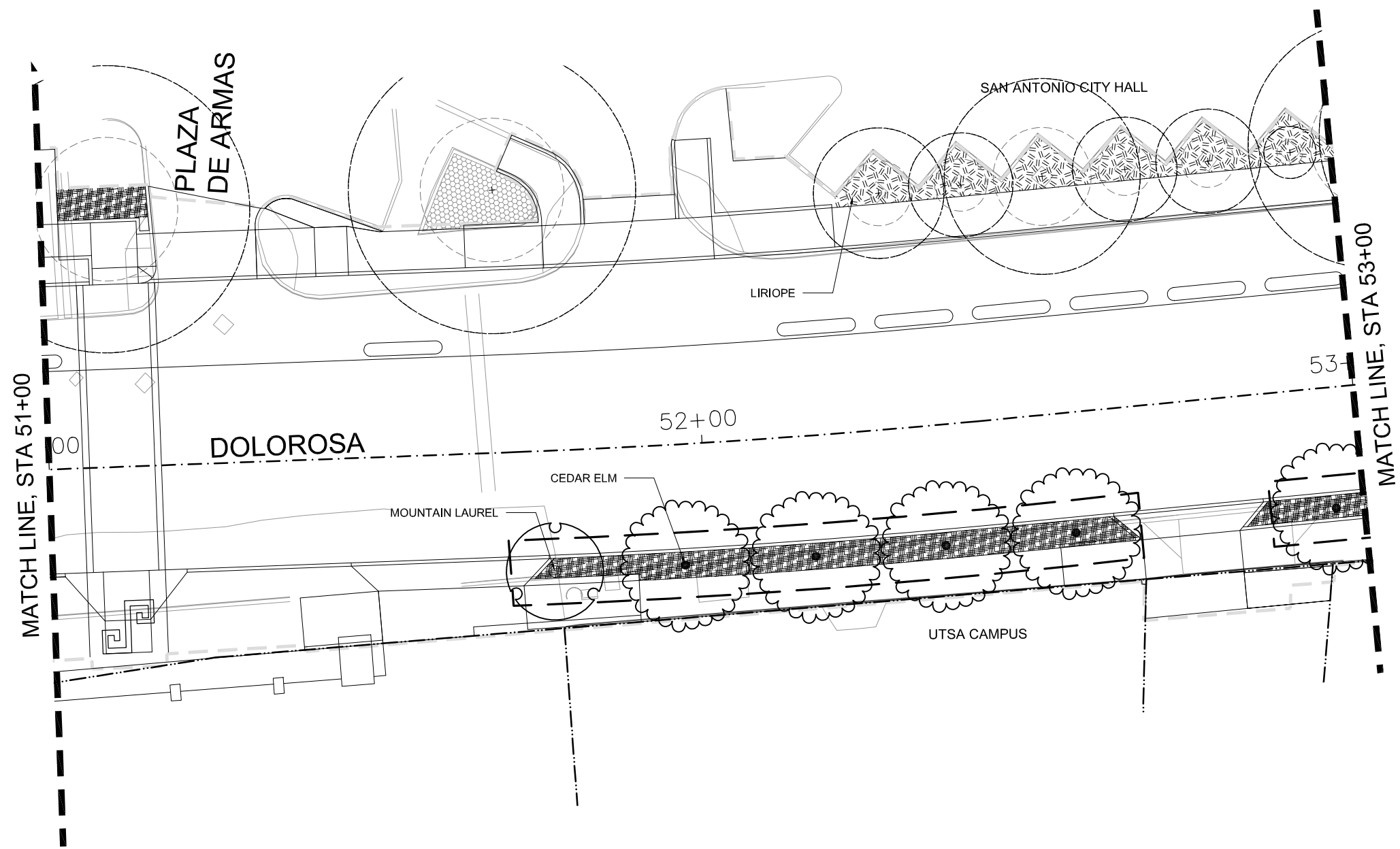

REV. NO.	DATE	DESCRIPTION	BY

**MOORE IACOFANO GOLTSMAN, INC.**  
 317 LEXINGTON AVENUE, SUITE 2 | TEL 210-600-9990  
 SAN ANTONIO, TEXAS, CA 78215 | www.migcom.com

  
**PAPE-DAWSON ENGINEERS**  
 SAN ANTONIO | AUSTIN | HOUSTON | FORT WORTH | DALLAS  
 2000 NW LOOP 410 | SAN ANTONIO, TX 78218 | 210.876.9000  
 TEXAS ENGINEERING FIRM #170 | TEXAS SURVEYING FIRM #10028800











**CITY OF SAN ANTONIO**  
**PUBLIC WORKS DEPARTMENT**

DOLOROSA  
**TREE PRESERVATION & PLANTING PLAN**

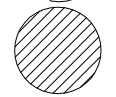
STA 51+00 TO STA 53+00

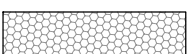
SHEET 15 OF 16

### PLANT LEGEND

- |   |  |   |
|---|--|---|
|  PLANT SYMBOLS, SEE PLANT SCHEDULE                 |  (E) TREE TO BE PROTECTED WITH ROOT ZONE (SEE INVENTORY SHEET) |  RIGHT OF WAY  |
|  CRUSHED STONE MULCH                               |  TREE TO BE REMOVED  |  LIMIT OF WORK |
|  EXISTING LANDSCAPE TO REMAIN (SEE PLANTING NOTES) |  |  MATCHLINE     |
|  STRUCTURAL SOIL                                   |  |   |

DESIGN	CHECKED	DRAWN	PROJECT NO.	SUBMITTAL	SHEET NO.
RD/AM	RD/AM	TM/RD	23-03763	70%	374

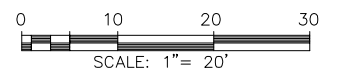
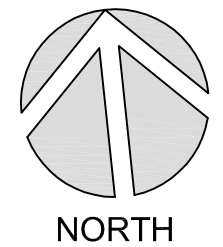
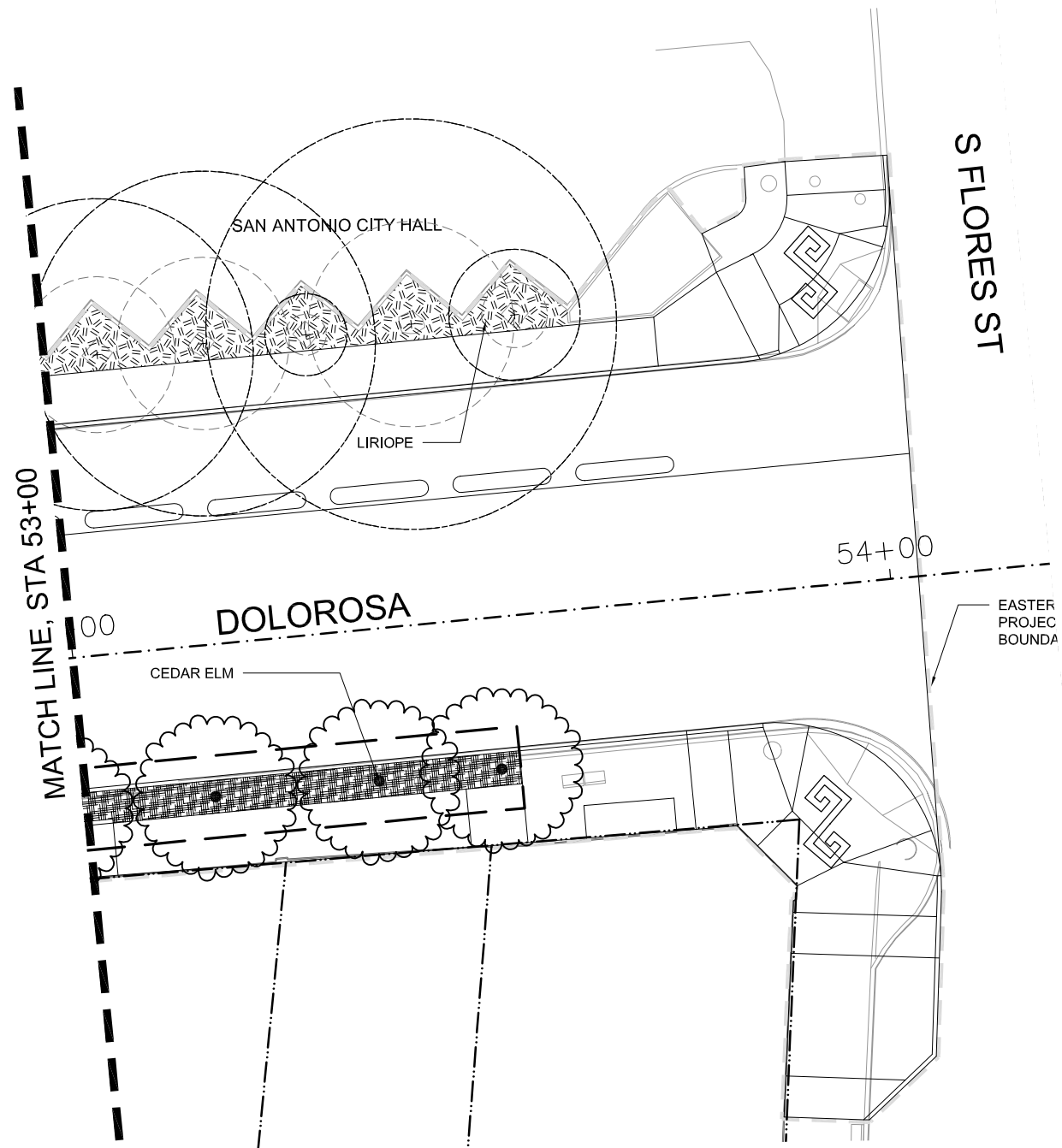

REV. NO.	DATE	DESCRIPTION	BY

MOORE IACOFANO GOLTSMAN, INC.  
 317 LEXINGTON AVENUE, SUITE 2  
 SAN ANTONIO, TEXAS, CA 78215  
 TEL 210-600-9990  
 www.migcom.com



SAN ANTONIO | AUSTIN | HOUSTON | FORT WORTH | DALLAS  
 2000 NW LOOP 410 | SAN ANTONIO, TX 78219 | 210.376.9000  
 TEXAS ENGINEERING FIRM #170 | TEXAS SURVEYING FIRM #10028600



CITY OF SAN ANTONIO  
**PUBLIC WORKS DEPARTMENT**

DOLOROSA  
**TREE PRESERVATION & PLANTING PLAN**

STA 53+00 TO STA 55+00

SHEET 16 OF 16

**PLANT LEGEND**



PLANT SYMBOLS, SEE PLANT SCHEDULE



CRUSHED STONE MULCH

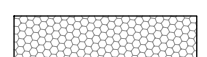

EXISTING LANDSCAPE TO REMAIN (SEE PLANTING NOTES)



STRUCTURAL SOIL



(E) TREE TO BE PROTECTED WITH ROOT ZONE (SEE INVENTORY SHEET)



TREE TO BE REMOVED

----- RIGHT OF WAY

- - - - - LIMIT OF WORK

----- MATCHLINE

DESIGN	CHECKED	DRAWN	PROJECT NO.	SUBMITTAL	SHEET NO.
RD/AM	RD/AM	TM/RD	23-03763	70%	375

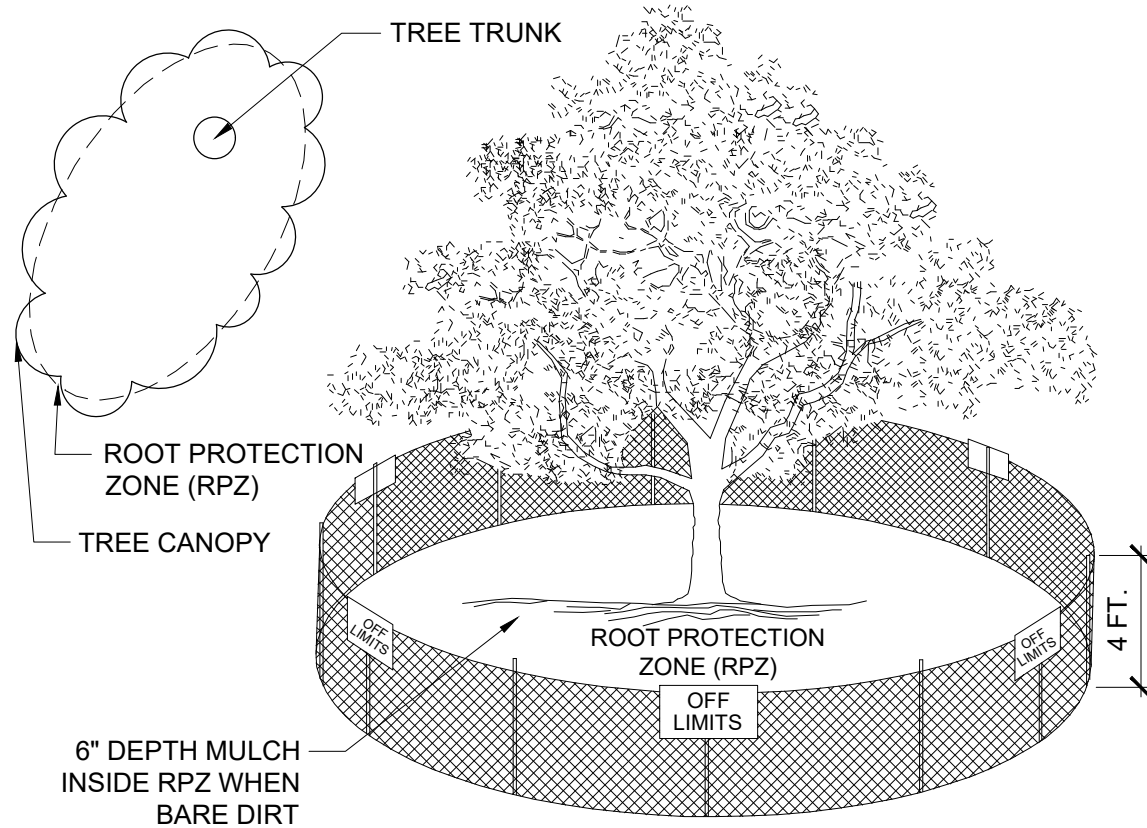

**NOTE:**

1. THE FENCING SHOWN ABOVE IS DIAGRAMATIC ONLY AND WILL CONFORM TO THE DRIP LINE AND LIMITED TO PROJECT BOUNDARY.
2. FOR ACCEPTABLE FENCING MATERIALS SEE SPECIFICATIONS.

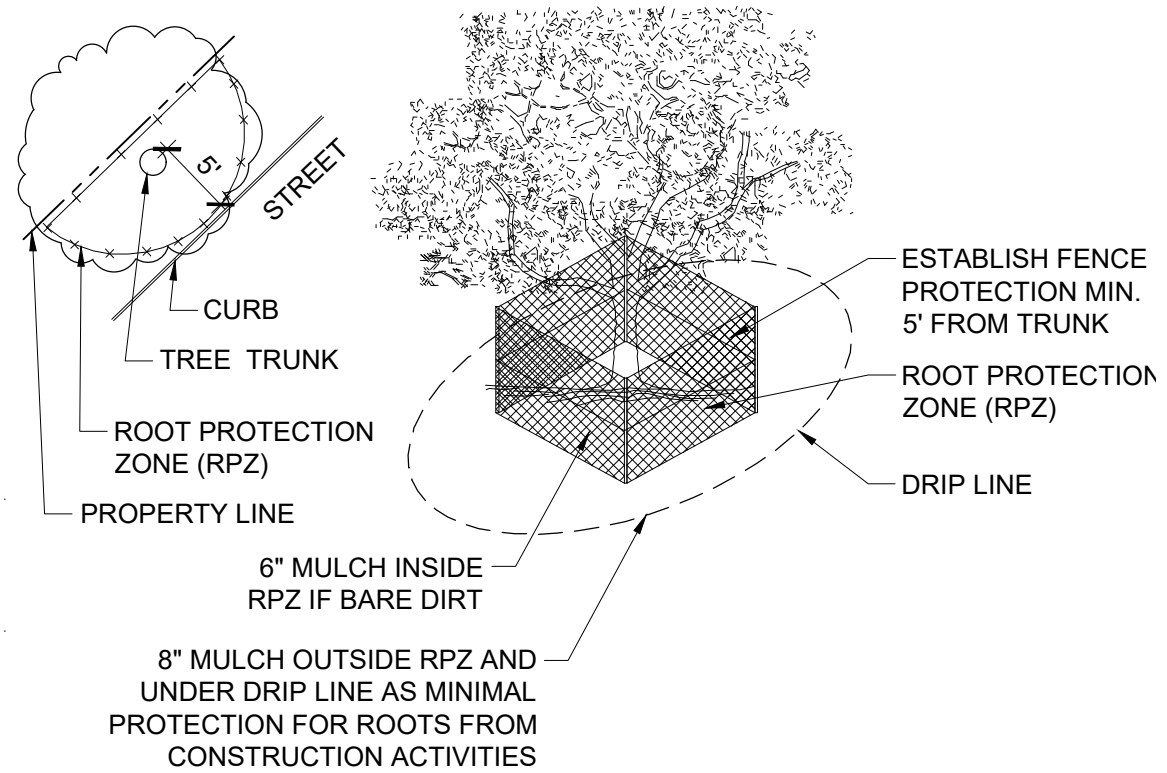

**NOTE:**

1. OPTION USED FOR TIGHT CONSTRUCTION AREAS OR WHEN CONSTRUCTION OCCURS IN ROOT PROTECTION ZONE.
2. SEE SPECIFICATIONS FOR ACCEPTABLE FENCING MATERIALS.

**1** TREE PROTECTION - LEVEL 1  
NOT TO SCALE

**2** TREE PROTECTION - LEVEL 2  
NOT TO SCALE

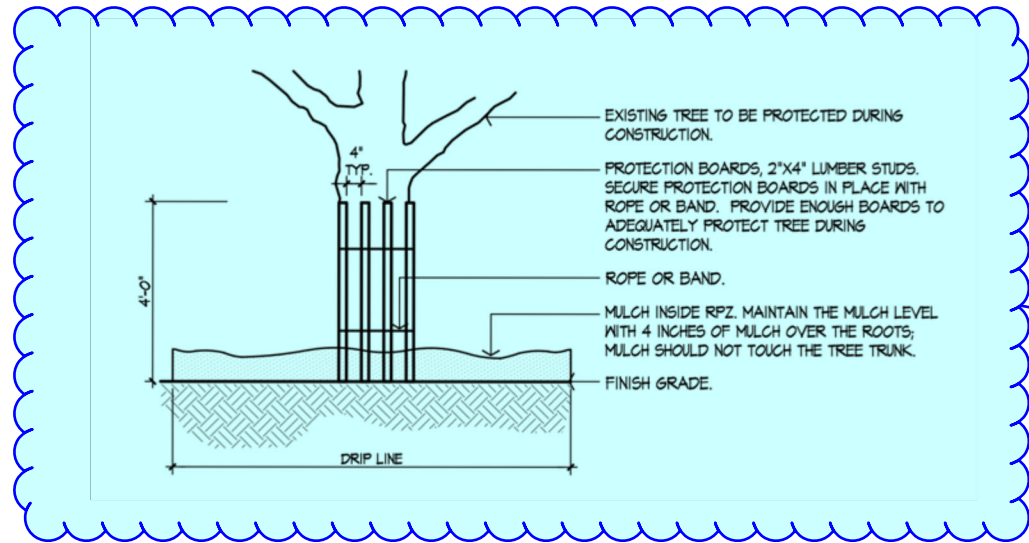

Blurry when zoomed. Ensure that this is digital linework and not an image.

**3** TREE PROTECTION LEVEL 2B  
NOT TO SCALE

REV. NO.	DATE	DESCRIPTION	BY
MOORE IACOFANO GOLTSMAN, INC. 317 LEXINGTON AVENUE, SUITE 2 SAN ANTONIO, TEXAS, CA 78215 TEL 210-600-9990 www.migcom.com			

**PAPE-DAWSON ENGINEERS**  
 SAN ANTONIO | AUSTIN | HOUSTON | FORT WORTH | DALLAS  
 2000 HW LOOP 410 | SAN ANTONIO, TX 78219 | 210.375.9000  
 TEXAS ENGINEERING FIRM #470 | TEXAS SURVEYING FIRM #10028800

CITY OF SAN ANTONIO  
**PUBLIC WORKS DEPARTMENT**  
 DOLOROSA

TREE PRESERVATION DETAILS

DESIGN	CHECKED	DRAWN	PROJECT NO.	SUBMITTAL	SHEET NO.
RD/AM	RD/AM	TM/RD	23-03763	70%	376

TREES THAT ARE MARKED TO BE PRESERVED ON A SITE PLAN AND FOR WHICH UTILITIES MUST PASS THROUGH THEIR ROOT PROTECTION ZONES MAY REQUIRE TUNNELING AS OPPOSED TO OPEN TRENCHES. THE DECISION TO TUNNEL WILL BE DETERMINED ON A CASE BY CASE BASIS BY THE ENGINEER.

TUNNELS SHALL BE DUG THROUGH THE ROOT PROTECTION ZONE IN ORDER TO MINIMIZE ROOT DAMAGE.

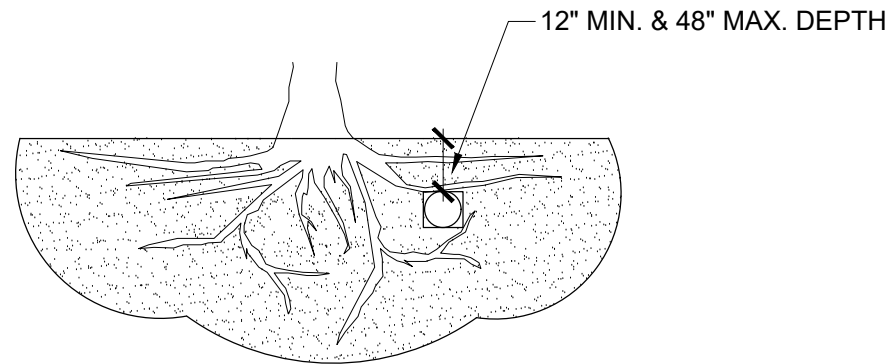

TUNNEL TO MINIMIZE ROOT DAMAGE (TOP) AS OPPOSED TO SURFACE-DUG TRENCHES IN ROOT PROTECTION ZONE WHEN THE 5' MINIMUM DISTANCE FROM TRUNK CANNOT BE ACHIEVED.

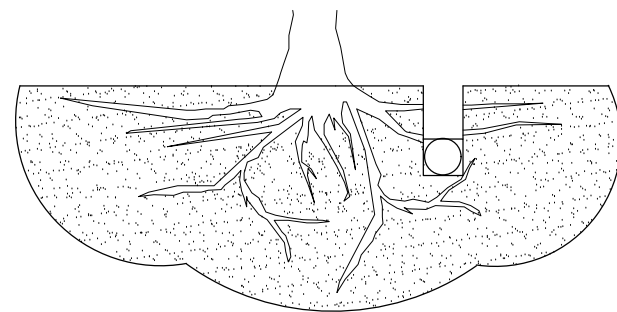

OPEN TRENCHING MAY BE USED IF EXPOSED TREE ROOTS DO NOT EXCEED 3" OR ROOTS CAN BE BENT BACK.

**1** BORING AT TREE ROOT ZONE  
NOT TO SCALE

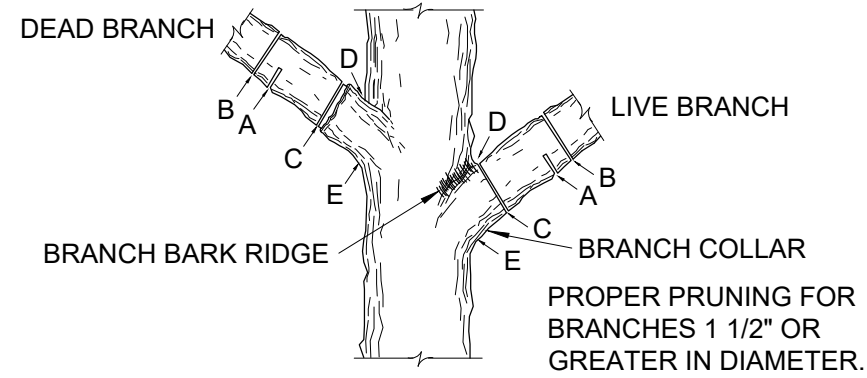

NOTE: DO NOT CUT FROM D TO E.

1. FIRST CUT - TO PREVENT THE BARK FROM BEING PEELED WHEN THE BRANCH FALLS.
2. SECOND CUT - TO REDUCE THE WEIGHT OF BRANCH.
3. FINAL CUT - ALLOW FOR HEALING COLLAR BUT NO STUBS
4. BRANCH RIDGES - INDENT PROPERLY BRANCH RIDGES, WHICH ARE SITES FOR DECAY.

FOR OAKS ONLY: PAINT ALL WOUNDS OR CUTS WITH PRUNING PAINT WITHIN 20 MIN. TO PREVENT THE SPREAD OF OAK WILT.

**2** TREE PRUNING  
NOT TO SCALE

REV. NO.	DATE	DESCRIPTION	BY

 MOORE IACOFANO GOLTSMAN, INC.  
 317 LEXINGTON AVENUE, SUITE 2  
 SAN ANTONIO, TEXAS, CA 78215 TEL 210-600-9990  
 www.migcom.com

  
 SAN ANTONIO | AUSTIN | HOUSTON | FORT WORTH | DALLAS  
 2080 NW LOOP 419 | SAN ANTONIO, TX 78219 | 210.375.9900  
 TEXAS ENGINEERING FIRM #470 | TEXAS SURVEYING FIRM #10028600

 CITY OF SAN ANTONIO  
 PUBLIC WORKS DEPARTMENT

DOLOROSA

TREE PRESERVATION DETAILS

DESIGN	CHECKED	DRAWN	PROJECT NO.	SUBMITTAL	SHEET NO.
RD/AM	RD/AM	TM/RD	23-03763	70%	377

TREE PRESERVATION INVENTORY TO BE ADDED IN 95% SUBMITTAL

REV. NO.	DATE	DESCRIPTION	BY



**MOORE IACOFANO GOLTSMAN, INC.**  
317 LEXINGTON AVENUE, SUITE 2  
SAN ANTONIO, TEXAS, CA 78215

TEL 210-600-9990  
[www.migcom.com](http://www.migcom.com)



**PAPE-DAWSON ENGINEERS**

SAN ANTONIO | AUSTIN | HOUSTON | FORT WORTH | DALLAS  
2000 NW LOOP 410 | SAN ANTONIO, TX 78213 | 210.376.9000  
TEXAS ENGINEERING FIRM #170 | TEXAS SURVEYING FIRM #10028900



**CITY OF SAN ANTONIO**  
**PUBLIC WORKS DEPARTMENT**

DOLOROSA

TREE PRESERVATION INVENTORY

DESIGN	CHECKED	DRAWN	PROJECT NO.	SUBMITTAL	SHEET NO.
RD/AM	RD/AM	TM/RD	23-03763	70%	378



GENERAL NOTES	
A.	CONTRACTOR SHALL FAMILIARIZE HIMSELF WITH EXISTING SITE CONDITIONS AND REVIEW ALL RELATED DRAWINGS AND SPECIFICATIONS PRIOR TO BID.
B.	THE DRAWINGS ARE DIAGRAMMATIC. CONTRACTOR SHALL VERIFY FIELD CONDITIONS AND DETERMINE CONDUIT ROUTING AND EXACT LOCATIONS OF EQUIPMENT AND DEVICES. NOTIFY THE ENGINEER IF THE APPROXIMATE CONDUIT ROUTING SHOWN ON PLANS IS NOT FEASIBLE. CONTRACTOR SHALL NOTIFY ENGINEER OF ANY CONFLICTS PRIOR TO ROUGH-IN.
C.	LOCATIONS OF DEVICES ARE DIAGRAMMATIC. EXACT LOCATIONS SHALL BE DETERMINED IN THE FIELD. CONTRACTOR SHALL NOTIFY ENGINEER OF ANY CONFLICTS PRIOR TO ROUGH-IN.
D.	ALL ELECTRICAL WORK SHALL BE IN ACCORDANCE WITH THE CURRENT ISSUE OF THE NATIONAL ELECTRIC CODE AND ALL APPLICABLE LOCAL CODES. ALL WORK SHALL MATCH THE EXISTING BUILDING'S ELECTRICAL INSTALLATION. ALL SYSTEMS SHALL BE INSTALLED IN A WORKMANLIKE MANNER IN ACCORDANCE WITH APPLICABLE STANDARDS AND SPECIFICATIONS APPROVED BY ALL AUTHORITIES HAVING JURISDICTION.
E.	PROVIDE A TYPED PANEL DIRECTORY FOR EACH NEW OR MODIFIED ELECTRICAL PANEL. DIRECTORY SHALL IDENTIFY THE CIRCUIT NUMBER, DEVICES SERVED, AND LOCATION OF DEVICES BY ROOM NUMBER. FILE COPY OF DIRECTORIES WITH THE OWNER'S REPRESENTATIVE WHEN WORK IS COMPLETED, AND PROVIDE COPIES WITH THE OWNER'S MANUALS.
F.	INDICATED SPARE AND/OR SPACES IN ALL EQUIPMENT ON THE ELECTRICAL ONE-LINE DIAGRAM AND IN THE PANEL SCHEDULES ARE THE MINIMUM NUMBER REQUIRED FOR THIS PROJECT.
G.	UNLESS OTHERWISE NOTED ELECTRICAL INSTALLATION SHALL MEET TXDOT ELECTRICAL STANDARDS.
H.	REFERENCE TXDOT DRAWING 'ELECTRICAL DETAILS CONDUITS & NOTES ED(1)-14 FOR ADDITIONAL MATERIALS AND INSTALLATION REQUIREMENTS.
I.	REFERENCE TXDOT DRAWING 'ELECTRICAL DETAILS CONDUCTORS ED(3)-14 FOR ADDITIONAL MATERIALS AND INSTALLATION REQUIREMENTS.
J.	REFERENCE TXDOT DRAWING 'ELECTRICAL DETAILS GROUND BOXES ED(4)-14 FOR ADDITIONAL MATERIALS AND INSTALLATION REQUIREMENTS.
K.	CONTRACTOR TO CALL - 1800-DIG-TESS FOR MARKING OF ALL UNDERGROUND UTILITIES BEFORE PROCEEDING TO BEGIN ANY TRENCHING.

### LIGHTING GENERAL NOTES

A.	ELECTRICAL DRAWINGS INDICATE GENERAL LOCATIONS OF LIGHTING FIXTURES REFER TO LANDSCAPE DRAWINGS FOR COORDINATION AND LOCATIONS. IF THERE IS A DIFFERENCE IN QUANTITY OF FIXTURES SHOWN ON THE ARCHITECTURAL AND ELECTRICAL DRAWINGS, THEY SHALL USE THE GREATER QUANTITY FOR BIDDING AND CONTACT THE DESIGN TEAM FOR FINAL RESOLUTION.
B.	COORDINATE REMOVAL OF CPS ENERGY MAINTAINED ROADWAY LIGHTING WITH CPS ENERGY REPRESENTATIVE.

### POWER GENERAL NOTES

A.	REFERENCE EQUIPMENT LIGHTING PLANS FOR REQUIREMENTS AND ADDITIONAL INFORMATION OF TAGGED EQUIPMENT SHOWN ON PLAN.
B.	RECEPTACLES SHALL BE TAMPER PROOF, GFCI TYPE. PROVIDE "WHILE IN-USE", NEMA 3R, NON METALLIC COVERS FOR EXTERIOR RECEPTACLES EQUAL TO HUBBELL TAYMAC #ML45G.
C.	ALL RECEPTACLES SHALL BE COMMERCIAL SPECIFICATION GRADE UNLESS NOTED OTHERWISE.

ABBREVIATION	DESCRIPTION
A	AMPERE(S)
ABV	ABOVE
AIC	AMPERE INTERRUPTING CAPACITY
AHJ	AUTHORITY HAVING JURISDICTION
C	CONDUIT
CB	CIRCUIT BREAKER
CKT	CIRCUIT
COND	CONDUCTOR
CU	COPPER
DIA	DIAMETER
EC	ELECTRICAL CONTRACTOR
EMT	ELEC. METALLIC TUBING
EXIST	EXISTING
FT	FEET, FOOT
GALV	GALVANIZED
GC	GENERAL CONTRACTOR
GFCI	GROUND FAULT CIRCUIT INTERRUPTER
GND	GROUND
HOA	HAND OFF AUTOMATIC
ID	INSIDE DIAMETER
IMC	INTERMEDIATE STEEL CONDUIT
IN	INCHES
JB	JUNCTION BOX
KV	KILOVOLT
KVA	KILOVOLT AMPERE
KW	KILOWATT
LED	LIGHT EMITTING DIODE
LGT	LIGHTING
M	MANHOLE
MCB	MAIN CIRCUIT BREAKER
MAX	MAXIMUM
MIN	MINIMUM
MLO	MAIN LUGS ONLY
MTG	MOUNTING
N/A	NOT APPLICABLE
NC	NORMALLY CLOSED
NEC	NATIONAL ELECTRICAL CODE
NFPA	NATIONAL FIRE PROTECTION ASSOCIATION
NF	NON FUSED
N.O.	NORMALLY OPEN
N.T.S.	NOT-TO-SCALE
N, NEMA	NEMA=NATIONAL ELECTRICAL MANUFACTURERS ASSOCIATION
OC	ON CENTER
OFCI	OWNER FURNISHED CONTRACTOR INSTALLED
OH	OVERHEAD
P	POLE
PNL	PANELBOARD
PSI	POUNDS PER SQUARE INCH
PVC	POLY VINYL CHLORIDE CONDUIT
PWR	POWER
RGS	RIGID GALVANIZED STEEL CONDUIT
RMC	RIGID METAL CONDUIT
SF	SQUARE FEET, FOOT
SPD	SURGE PROTECTIVE DEVICE
SQ	SQUARE
SW	SWITCH
TYP.	TYPICAL
UEB	UNDERGROUND ELECTRIC BRANCH CIRCUIT
U.N.O.	UNLESS NOTED OTHERWISE
V	VOLT(S)
W	WIRE
WP	WEATHERPROOF
Z	IMPEDANCE
1P	ONE POLE
2P	TWO POLE
3P	THREE POLE
∅	PHASE

SYMBOL	DESCRIPTION
	PEDESTRIAN LIGHTING POLE
	GFCI RECEPTACLE WITH WHILE-IN-USE COVER
	CONDUIT UNDERGROUND OR CAST IN STRUCTURE WITH CONDUCTORS. SEE SUMMARY.
	GROUND BOX WITH CONC. APRON
	ELECTRIC SERVICE/POLE #NUMBER
	CONDUIT/CONDUCTOR RUN CALLOUT
	DEMOLITION WORK KEY NOTE
	NEW WORK KEY NOTE
	POWER POLE
	EQUIPMENT CONNECTION, HARD WIRED

INTERIM REVIEW

DOCUMENT INCOMPLETE. NOT INTENDED FOR PERMIT, BIDDING OR CONSTRUCTION.

ENGINEER: TRAVIS E. WILTSHIRE

P.E. SERIAL NO: 85219

COMPANY NAME: CNG ENGINEERING, PLLC.

COMPANY REG. NO. F-7964

DATE: 01-20-2023

REV. NO.	DATE	DESCRIPTION	BY

**CNG ENGINEERING**  
MEP DESIGN | PLANNING | COMMISSIONING

1917 N NEW BRAUNFELS AVE, SUITE 201  
SAN ANTONIO, TEXAS 78208  
T 210.224.8841 F 210.224.8224  
www.cngengineering.com  
TBPE FIRM # F-7964

**PAPE-DAWSON ENGINEERS**

SAN ANTONIO | AUSTIN | HOUSTON | FORT WORTH | DALLAS  
2000 NW LOOP 410 | SAN ANTONIO, TX 78218 | 210.375.9000  
TEXAS ENGINEERING FIRM #170 | TEXAS SURVEYING FIRM #10028800

CITY OF SAN ANTONIO  
**PUBLIC WORKS DEPARTMENT**

DOLOROSA

**ELECTRICAL SYMBOLS & ABBREVIATIONS**

DESIGN	CHECKED	DRAWN	PROJECT NO.	SUBMITTAL	SHEET NO.
JC	JC	CDC	23-03763	70%	379

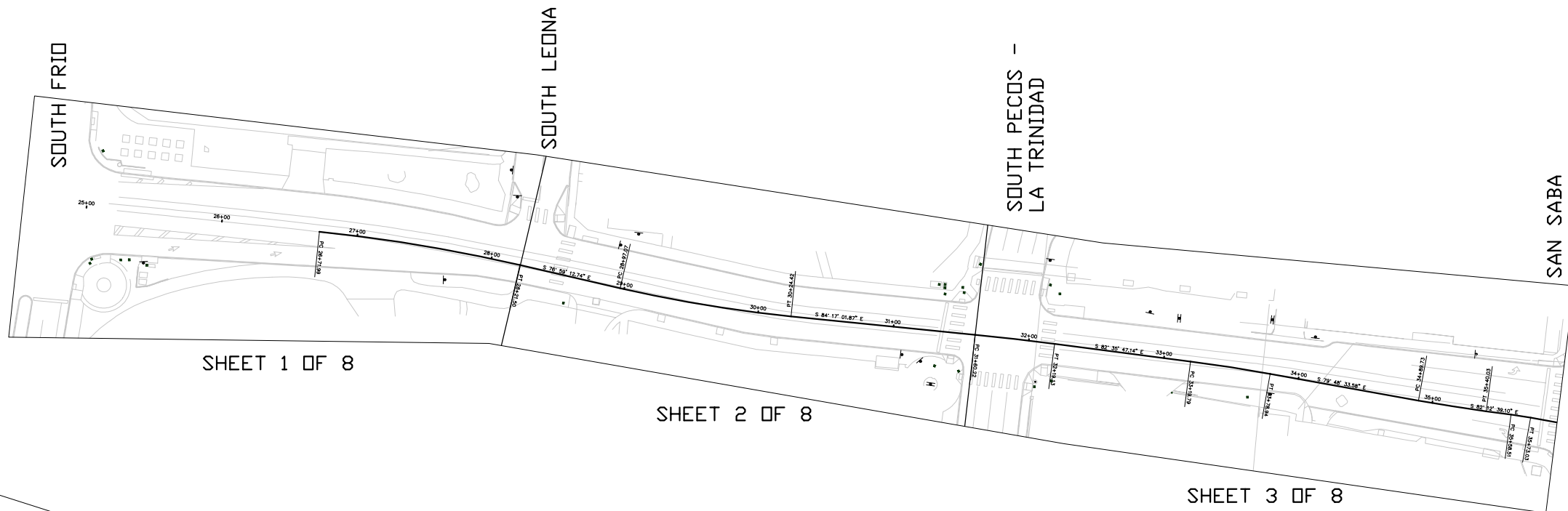

SHEET 1 OF 8

SHEET 2 OF 8

SHEET 3 OF 8

SAN SABA

DOLOROSA



SHEET 4 OF 8

SHEET 5 OF 8

DOLOROSA

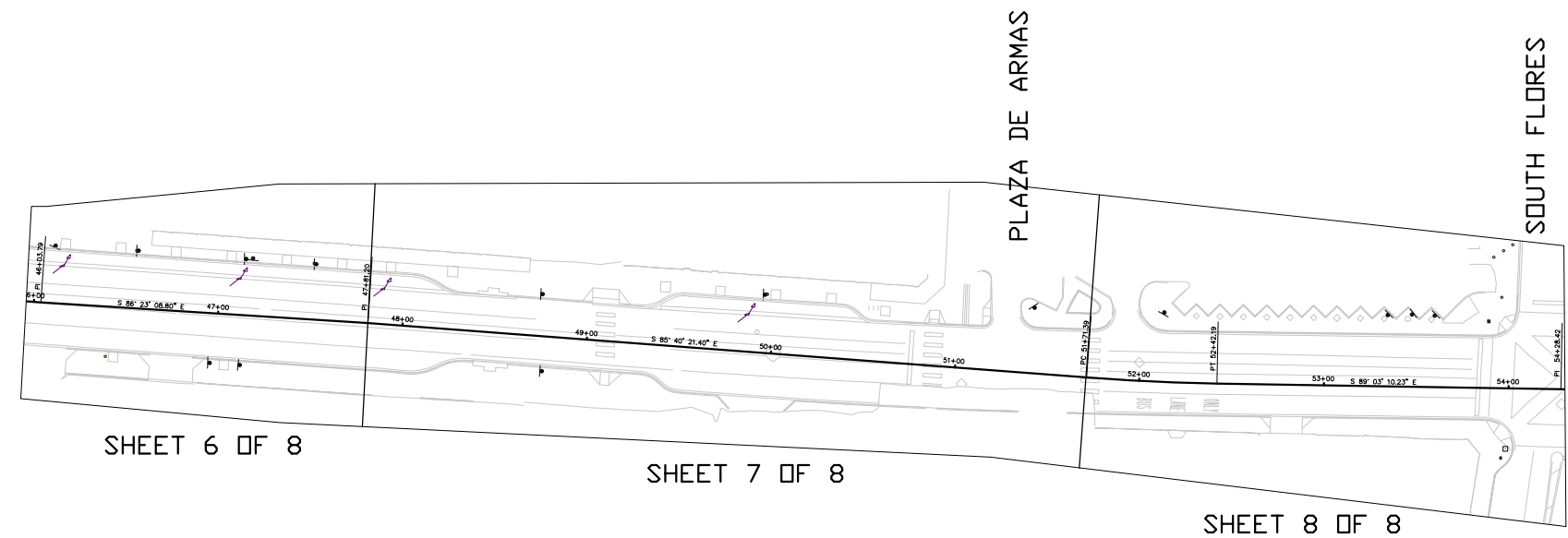

SHEET 6 OF 8

SHEET 7 OF 8

SHEET 8 OF 8

DOLOROSA

INTERIM REVIEW  
 DOCUMENT INCOMPLETE. NOT INTENDED FOR PERMIT, BIDDING OR CONSTRUCTION.  
 ENGINEER: TRAVIS E. WILTSHIRE  
 P.E. SERIAL NO.: 85219  
 COMPANY NAME: CNG ENGINEERING, PLLC.  
 COMPANY REG. NO. F-7964  
 DATE: 01-20-2023

REV. NO.	DATE	DESCRIPTION	BY



**CNG ENGINEERING**  
 MEP DESIGN | PLANNING | COMMISSIONING  
 1917 N NEW BRAUNFELS AVE, SUITE 201  
 SAN ANTONIO, TEXAS 78208  
 T 210.224.8841 F 210.224.8224  
 www.cngengineering.com  
 TBPE FIRM # F-7964



**PAPE-DAWSON ENGINEERS**  
 SAN ANTONIO | AUSTIN | HOUSTON | FORT WORTH | DALLAS  
 2000 NW LOOP 410 | SAN ANTONIO, TX 78218 | 210.375.9000  
 TEXAS ENGINEERING FIRM #170 | TEXAS SURVEYING FIRM #10028800



CITY OF SAN ANTONIO  
**PUBLIC WORKS DEPARTMENT**

DOLOROSA  
 DEMOLITION  
 ELECTRICAL SHEET  
 LAYOUT

DESIGN	CHECKED	DRAWN	PROJECT NO.	SUBMITTAL	SHEET NO.
JC	JC	CDC	23-03763	70%	380

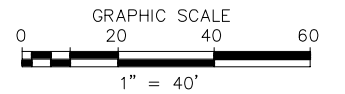
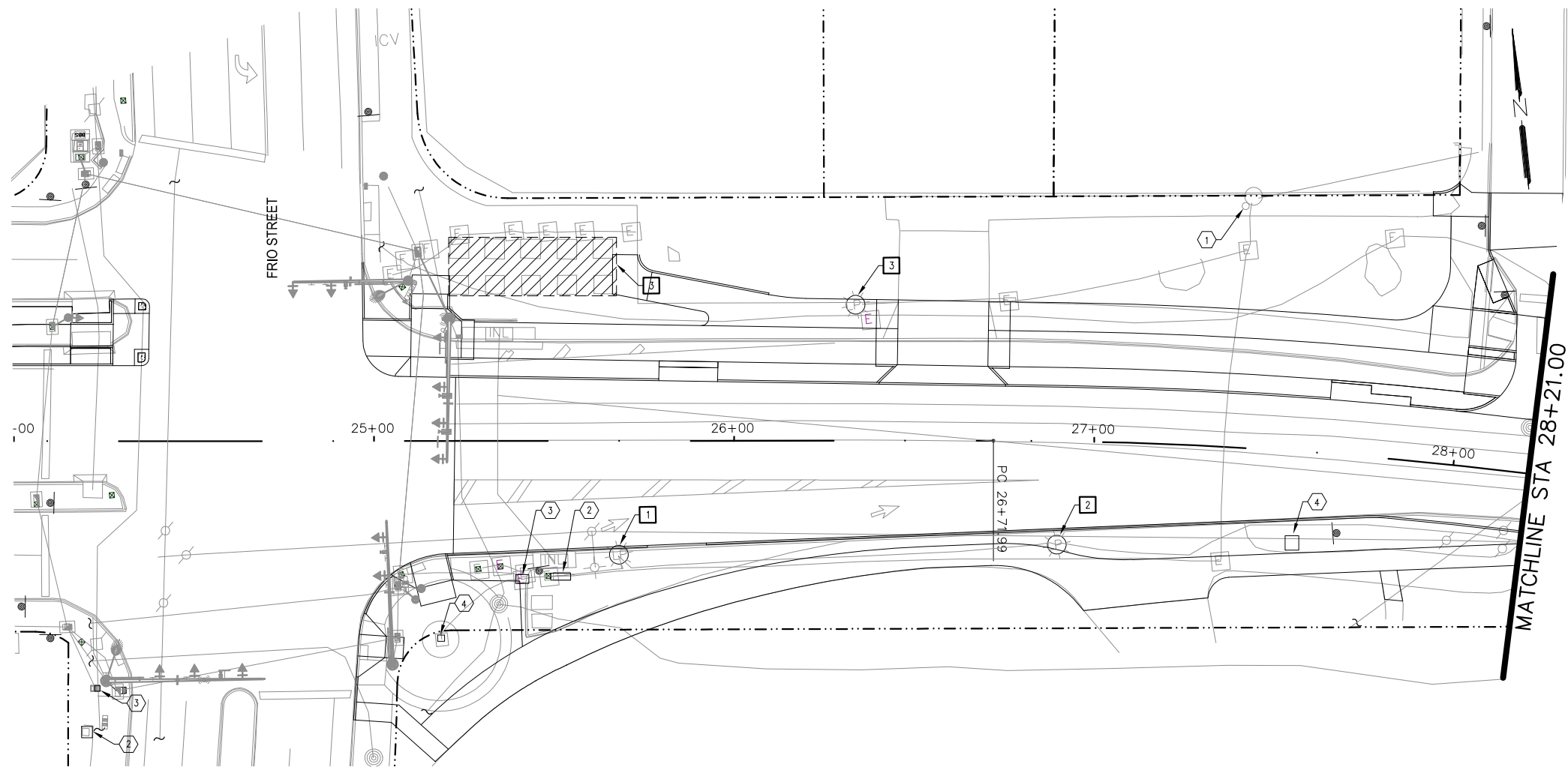

**# KEYED NOTES: (THIS SHEET ONLY)**

1. EXISTING CPS ENERGY ELECTRICAL EQUIPMENT TO REMAIN.
2. EXISTING METER CABINET TO REMAIN.
3. EXISTING METER PEDESTAL TO REMAIN.
4. EXISTING CITY OWNED DIGITAL DISPLAY TO REMAIN.
5. EXISTING UNIVERSITY STONE COLUMN PEDESTRIAN LIGHT TO REMAIN.

**# DEMO KEYED NOTES: (THIS SHEET ONLY)**

1. REMOVE CITY OWNED LUMINAIRE AND ASSOCIATED CONDUCTORS AND RETURN TO OWNER.
2. EXISTING CPSE STREET LIGHT FIXTURE TO BE REMOVED AND RELOCATED BY CPS ENERGY. COORDINATE REMOVAL WITH CPS ENERGY.
3. REMOVE DAMAGED WIRING AND DEVICES FROM TREE WELLS AND RETURN TO OWNER.

**GENERAL NOTES:**

1. CONTRACTOR TO COORDINATE WITH CPS ENERGY FOR REMOVAL AND RELOCATION OF CPSE EQUIPMENT.
2. PROTECT EXISTING TO REMAIN ELECTRICAL EQUIPMENT AND UNDERGROUND CIRCUITS. REPAIR AND RELOCATE AS NECESSARY TO MAINTAIN OPERATION. ADJUST ASSOCIATED IN-GRADE ELECTRICAL JUNCTION BOX COVER PLATES TO NEW ELEVATION. PROVIDE BOX EXTENSION AS NECESSARY.
3. REFER TO TRAFFIC SIGNAL DRAWINGS FOR TRAFFIC SIGNAL SCOPE OF WORK.

INTERIM REVIEW

DOCUMENT INCOMPLETE. NOT INTENDED FOR PERMIT, BIDDING OR CONSTRUCTION.

ENGINEER: TRAVIS E. WILTSHIRE

P.E. SERIAL NO: 85219

COMPANY NAME: CNG ENGINEERING, PLLC.

COMPANY REG. NO. F-7964

DATE: 01-20-2023

REV. NO.	DATE	DESCRIPTION	BY



**CNG ENGINEERING**  
MEP DESIGN | PLANNING | COMMISSIONING

1917 N NEW BRAUNFELS AVE, SUITE 201  
SAN ANTONIO, TEXAS 78208  
T 210.224.8841 F 210.224.8224  
www.cngengineering.com  
TBPE FIRM # F-7964



**PAPE-DAWSON ENGINEERS**

SAN ANTONIO | AUSTIN | HOUSTON | FORT WORTH | DALLAS  
2000 NW LOOP 410 | SAN ANTONIO, TX 78218 | 210.375.9000  
TEXAS ENGINEERING FIRM #170 | TEXAS SURVEYING FIRM #10028800

CITY OF SAN ANTONIO  
**PUBLIC WORKS DEPARTMENT**

DOLOROSA  
**DEMOLITION  
ELECTRICAL PLANS**

STA START TO STA 28+21.00

DESIGN	CHECKED	DRAWN	PROJECT NO.	SUBMITTAL	SHEET NO.
JC	JC	CDC	23-03763	70%	381

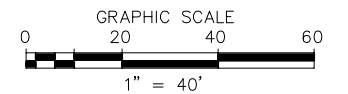
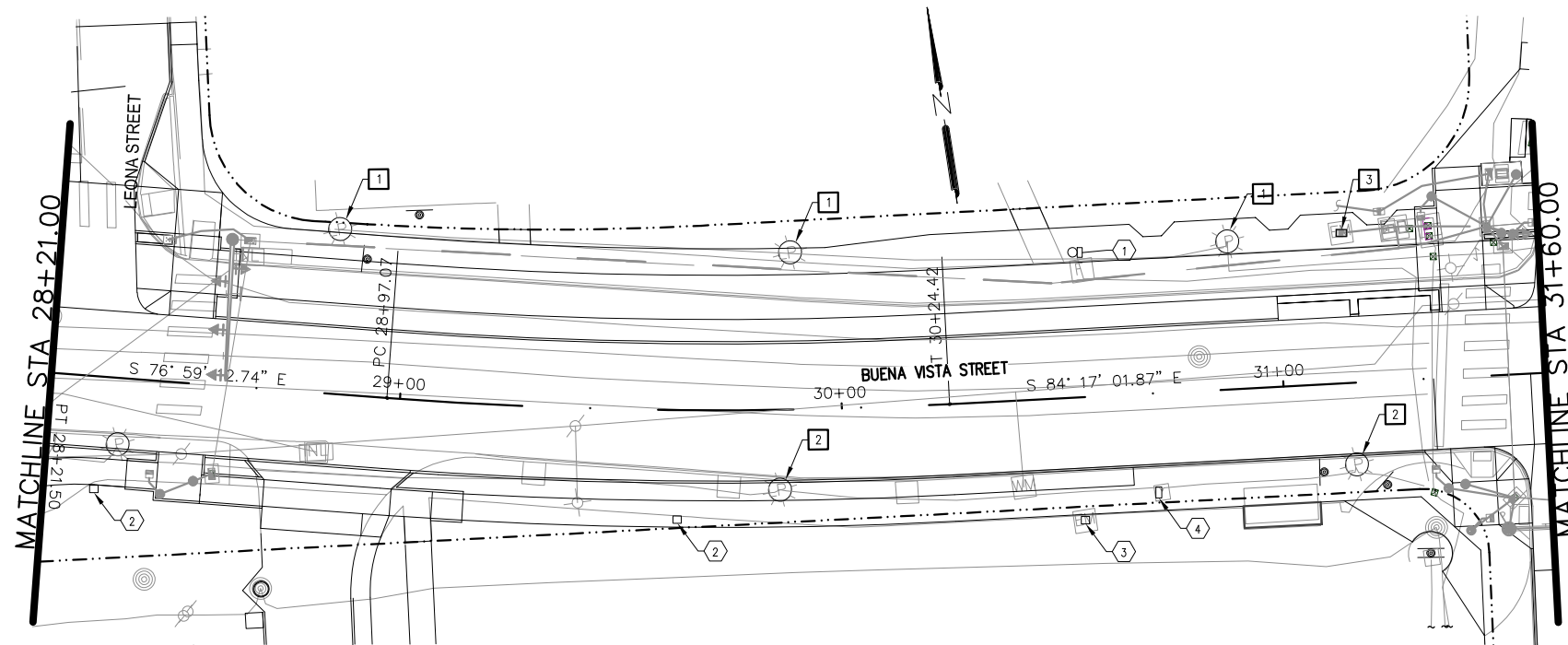

**# KEYED NOTES: (THIS SHEET ONLY)**

1. EXISTING TELECOMMUNICATIONS POLE AND CPS ENERGY ELECTRICAL METERED EQUIPMENT TO REMAIN.
2. EXISTING UNIVERSITY STONE COLUMN PEDESTRIAN LIGHT TO REMAIN.
3. EXISTING METER PEDESTAL TO REMAIN.
4. EXISTING CITY OWNED DIGITAL DISPLAY TO REMAIN.

**# DEMO KEYED NOTES: (THIS SHEET ONLY)**

1. REMOVE CITY OWNED LUMINAIRE AND ASSOCIATED CONDUCTORS AND RETURN TO OWNER.
2. EXISTING CPSE STREET LIGHT FIXTURE TO BE REMOVED AND RELOCATED BY CPS ENERGY. COORDINATE REMOVAL WITH CPS ENERGY.
3. TRAFFIC SIGNAL METER PEDESTAL TO BE RELOCATED. COORDINATE RELOCATION OF EQUIPMENT WITH CPS ENERGY.

**GENERAL NOTES:**

1. CONTRACTOR TO COORDINATE WITH CPS ENERGY FOR REMOVAL AND RELOCATION OF CPSE EQUIPMENT.
2. PROTECT EXISTING TO REMAIN ELECTRICAL EQUIPMENT AND UNDERGROUND CIRCUITS. REPAIR AND RELOCATE AS NECESSARY TO MAINTAIN OPERATION. ADJUST ASSOCIATED IN-GRADE ELECTRICAL JUNCTION BOX COVER PLATES TO NEW ELEVATION. PROVIDE BOX EXTENSION AS NECESSARY.
3. REFER TO TRAFFIC SIGNAL DRAWINGS FOR TRAFFIC SIGNAL SCOPE OF WORK.

INTERIM REVIEW

DOCUMENT INCOMPLETE. NOT INTENDED FOR PERMIT, BIDDING OR CONSTRUCTION.  
 ENGINEER: TRAVIS E. WILTSHIRE  
 P.E. SERIAL NO: 85219  
 COMPANY NAME: CNG ENGINEERING, PLLC.  
 COMPANY REG. NO. F-7964  
 DATE: 01-20-2023

REV. NO.	DATE	DESCRIPTION	BY



**CNG ENGINEERING**  
 MEP DESIGN | PLANNING | COMMISSIONING  
 1917 N NEW BRAUNFELS AVE, SUITE 201  
 SAN ANTONIO, TEXAS 78208  
 T 210.224.8841 F 210.224.8224  
 www.cngengineering.com  
 TBPE FIRM # F-7964



**PAPE-DAWSON ENGINEERS**  
 SAN ANTONIO | AUSTIN | HOUSTON | FORT WORTH | DALLAS  
 2000 NW LOOP 410 | SAN ANTONIO, TX 78218 | 210.875.9000  
 TEXAS ENGINEERING FIRM #170 | TEXAS SURVEYING FIRM #10028800



CITY OF SAN ANTONIO  
**PUBLIC WORKS DEPARTMENT**

DOLOROSA  
**DEMOLITION ELECTRICAL PLANS**  
 STA 28+22.00 TO STA 31+60.00

DESIGN	CHECKED	DRAWN	PROJECT NO.	SUBMITTAL	SHEET NO.
JC	JC	CDC	23-03763	70%	382

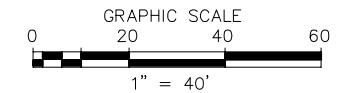
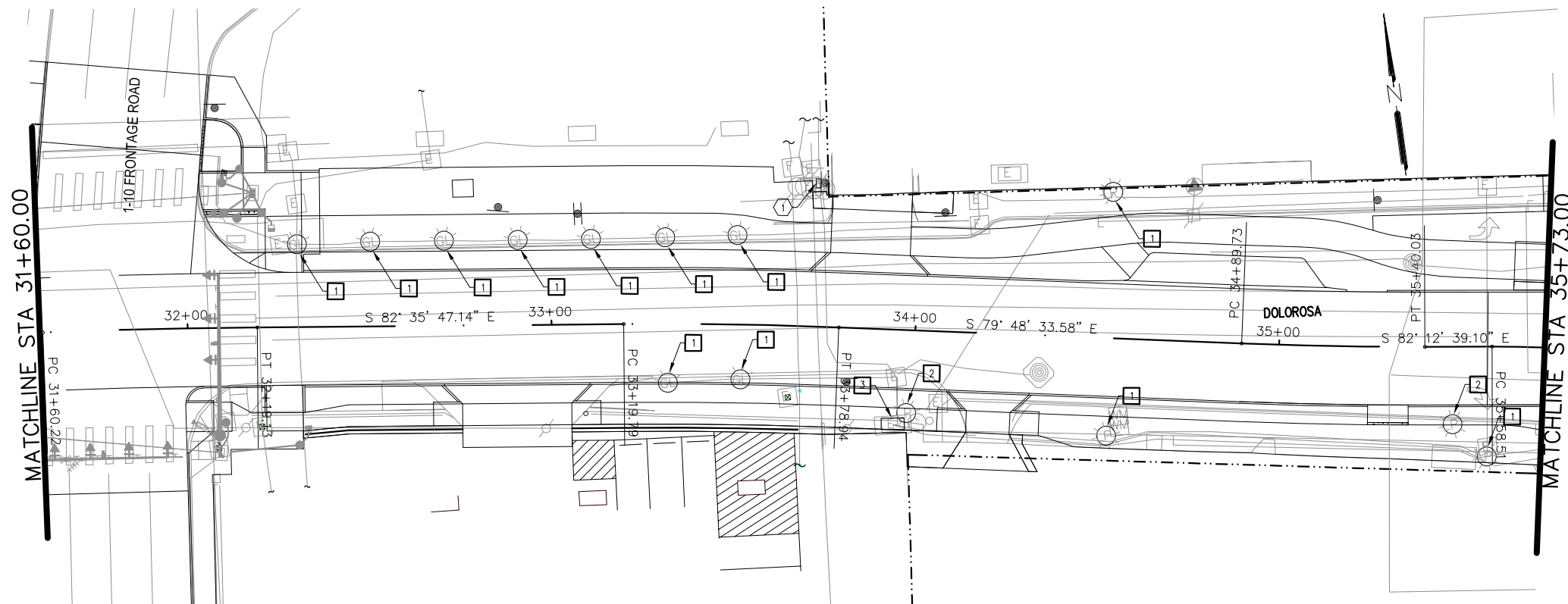

**# KEYED NOTES: (THIS SHEET ONLY)**

- EXISTING METER EQUIPMENT TO REMAIN.

**# DEMO KEYED NOTES: (THIS SHEET ONLY)**

- REMOVE CITY OWNED LUMINAIRE AND ASSOCIATED CONDUCTORS AND RETURN TO OWNER.
- EXISTING CPSE STREET LIGHT FIXTURE TO BE REMOVED AND RELOCATED BY CPS ENERGY. COORDINATE REMOVAL WITH CPS ENERGY.
- EXISTING PEDESTRIAN METER AND DISTRIBUTION CABINET TO BE RELOCATED AND UPGRADED. COORDINATE RELOCATION WITH CPS ENERGY.

**GENERAL NOTES:**

- CONTRACTOR TO COORDINATE WITH CPS ENERGY FOR REMOVAL AND RELOCATION OF CPSE EQUIPMENT.
- PROTECT EXISTING TO REMAIN ELECTRICAL EQUIPMENT AND UNDERGROUND CIRCUITS. REPAIR AND RELOCATE AS NECESSARY TO MAINTAIN OPERATION. ADJUST ASSOCIATED IN-GRADE ELECTRICAL JUNCTION BOX COVER PLATES TO NEW ELEVATION. PROVIDE BOX EXTENSION AS NECESSARY.
- REFER TO TRAFFIC SIGNAL DRAWINGS FOR TRAFFIC SIGNAL SCOPE OF WORK.

**INTERIM REVIEW**

DOCUMENT INCOMPLETE. NOT INTENDED FOR PERMIT, BIDDING OR CONSTRUCTION.  
 ENGINEER: TRAVIS E. WILTSHIRE  
 P.E. SERIAL NO: 85219  
 COMPANY NAME: CNG ENGINEERING, PLLC.  
 COMPANY REG. NO. F-7964  
 DATE: 01-20-2023

REV. NO.	DATE	DESCRIPTION	BY

**CNG ENGINEERING**  
 MEP DESIGN | PLANNING | COMMISSIONING  
 1917 N NEW BRAUNFELS AVE, SUITE 201  
 SAN ANTONIO, TEXAS 78208  
 T 210.224.8841 F 210.224.8224  
 www.cngengineering.com  
 TBPE FIRM # F-7964

**PAPE-DAWSON ENGINEERS**  
 SAN ANTONIO | AUSTIN | HOUSTON | FORT WORTH | DALLAS  
 2000 NW LOOP 410 | SAN ANTONIO, TX 78218 | 210.875.9000  
 TEXAS ENGINEERING FIRM #170 | TEXAS SURVEYING FIRM #10028800

CITY OF SAN ANTONIO  
**PUBLIC WORKS DEPARTMENT**

DOLOROSA  
 DEMOLITION  
 ELECTRICAL PLANS  
 STA 31+60.00 TO STA 53+73.00  
 SHEET 3 OF 8

DESIGN	CHECKED	DRAWN	PROJECT NO.	SUBMITTAL	SHEET NO.
JC	JC	CDC	23-03763	70%	383

MATCHLINE STA 35+73.00

MATCHLINE STA 41+44.00

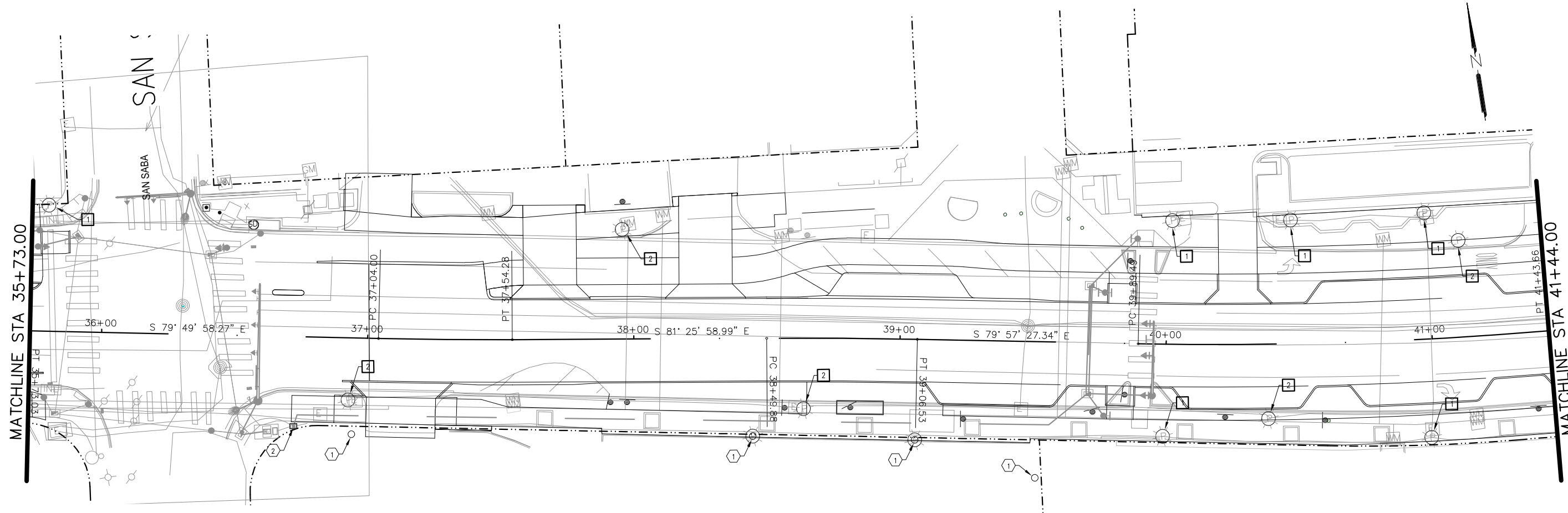

**# KEYED NOTES: (THIS SHEET ONLY)**

1. PEDESTRIAN POLE LIGHTS LOCATED ON LA QUINTA PROPERTY. REMOVAL WILL REQUIRE APPROVAL BY LA QUINTA PROPERTY OWNER.
2. ELECTRICAL METERED SERVICE NO. 3, 936 DOLOROSA ST. (INSTALLED AS PART OF SAN SABA ROAD RENOVATIONS) PROTECT DURING CONSTRUCTION

**# DEMO KEYED NOTES: (THIS SHEET ONLY)**

1. REMOVE CITY OWNED LUMINAIRE AND ASSOCIATED CONDUCTORS AND RETURN TO OWNER.
2. EXISTING CPSE STREET LIGHT FIXTURE TO BE REMOVED AND RELOCATED BY CPS ENERGY. COORDINATE REMOVAL WITH CPS ENERGY.

**GENERAL NOTES:**

1. CONTRACTOR TO COORDINATE WITH CPS ENERGY FOR REMOVAL AND RELOCATION OF CPSE EQUIPMENT.
2. PROTECT EXISTING TO REMAIN ELECTRICAL EQUIPMENT AND UNDERGROUND CIRCUITS. REPAIR AND RELOCATE AS NECESSARY TO MAINTAIN OPERATION. ADJUST ASSOCIATED IN-GRADE ELECTRICAL JUNCTION BOX COVER PLATES TO NEW ELEVATION. PROVIDE BOX EXTENSION AS NECESSARY.
3. REFER TO TRAFFIC SIGNAL DRAWINGS FOR TRAFFIC SIGNAL SCOPE OF WORK.

**INTERIM REVIEW**

DOCUMENT INCOMPLETE. NOT INTENDED FOR PERMIT, BIDDING OR CONSTRUCTION.  
 ENGINEER: TRAVIS E. WILTSHIRE  
 P.E. SERIAL NO: 85219  
 COMPANY NAME: CNG ENGINEERING, PLLC.  
 COMPANY REG. NO. F-7964  
 DATE: 01-20-2023

REV. NO.	DATE	DESCRIPTION	BY



**CNG ENGINEERING**  
 MEP DESIGN | PLANNING | COMMISSIONING  
 1917 N NEW BRAUNFELS AVE, SUITE 201  
 SAN ANTONIO, TEXAS 78208  
 T 210.224.8841 F 210.224.8224  
 www.cngengineering.com  
 TBPE FIRM # F-7964



**PAPE-DAWSON ENGINEERS**  
 SAN ANTONIO | AUSTIN | HOUSTON | FORT WORTH | DALLAS  
 2000 NW LOOP 410 | SAN ANTONIO, TX 78218 | 210.875.9000  
 TEXAS ENGINEERING FIRM #170 | TEXAS SURVEYING FIRM #10028800



CITY OF SAN ANTONIO  
**PUBLIC WORKS DEPARTMENT**

DOLOROSA  
**DEMOLITION  
 ELECTRICAL PLANS**

STA 53+73.00 TO STA 41+44.00

SHEET 4 OF 8

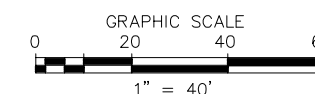

DESIGN	CHECKED	DRAWN	PROJECT NO.	SUBMITTAL	SHEET NO.
JC	JC	CDC	23-03763	70%	384

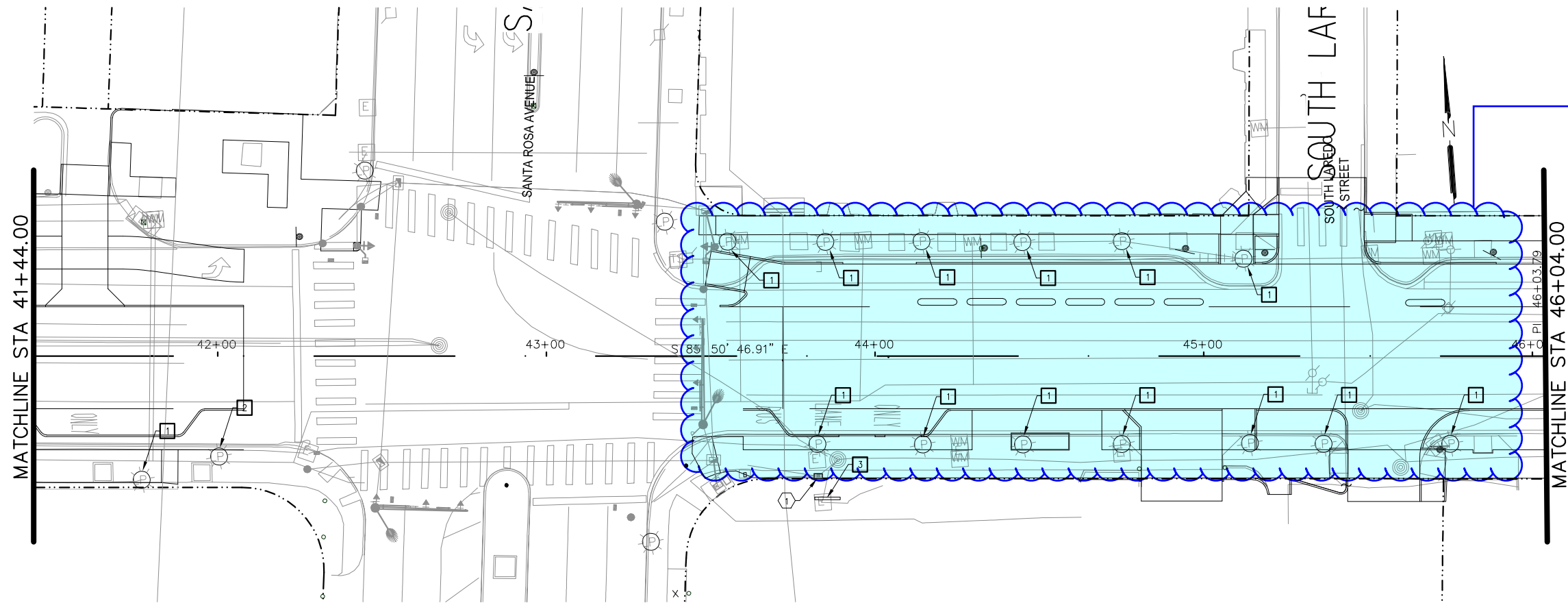

No ped poles salvaged east of Santa Rosa. Several of these are CPS hockey puck style luminaires and will need to be removed by CPS. Review and revise.

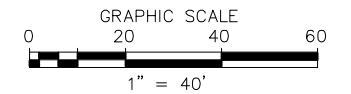

**# KEYED NOTES: (THIS SHEET ONLY)**

1. ELECTRICAL METERED SERVICE NO. 4, 720 DOLOROSA ST. (INSTALLED AS PART OF SANTA ROSA ROAD RENOVATIONS)

**# DEMO KEYED NOTES: (THIS SHEET ONLY)**

1. REMOVE CITY OWNED LUMINAIRE AND ASSOCIATED CONDUCTORS AND RETURN TO OWNER.
2. EXISTING CPSE STREET LIGHT FIXTURE TO BE REMOVED AND RELOCATED BY CPS ENERGY. COORDINATE REMOVAL WITH CPS ENERGY.
3. COORDINATE REMOVAL OF RACK MOUNTED PEDESTRIAN LIGHTING ELECTRICAL SERVICE AND EQUIPMENT WITH CPS ENERGY.

**GENERAL NOTES:**

1. CONTRACTOR TO COORDINATE WITH CPS ENERGY FOR REMOVAL AND RELOCATION OF CPSE EQUIPMENT.
2. PROTECT EXISTING TO REMAIN ELECTRICAL EQUIPMENT AND UNDERGROUND CIRCUITS. REPAIR AND RELOCATE AS NECESSARY TO MAINTAIN OPERATION. ADJUST ASSOCIATED IN-GRADE ELECTRICAL JUNCTION BOX COVER PLATES TO NEW ELEVATION. PROVIDE BOX EXTENSION AS NECESSARY.
3. REFER TO TRAFFIC SIGNAL DRAWINGS FOR TRAFFIC SIGNAL SCOPE OF WORK.

**INTERIM REVIEW**

DOCUMENT INCOMPLETE. NOT INTENDED FOR PERMIT, BIDDING OR CONSTRUCTION.  
 ENGINEER: TRAVIS E. WILTSHIRE  
 P.E. SERIAL NO.: 85219  
 COMPANY NAME: CNG ENGINEERING, PLLC.  
 COMPANY REG. NO. F-7964  
 DATE: 01-20-2023

REV. NO.	DATE	DESCRIPTION	BY



**CNG ENGINEERING**  
 MEP DESIGN | PLANNING | COMMISSIONING  
 1917 N NEW BRAUNFELS AVE, SUITE 201  
 SAN ANTONIO, TEXAS 78208  
 T 210.224.8841 F 210.224.8224  
 www.cngengineering.com  
 TBPE FIRM # F-7964



**PAPE-DAWSON ENGINEERS**  
 SAN ANTONIO | AUSTIN | HOUSTON | FORT WORTH | DALLAS  
 2000 NW LOOP 410 | SAN ANTONIO, TX 78218 | 210.875.9000  
 TEXAS ENGINEERING FIRM #170 | TEXAS SURVEYING FIRM #10028800



CITY OF SAN ANTONIO  
**PUBLIC WORKS DEPARTMENT**

DOLOROSA  
 DEMOLITION  
 ELECTRICAL PLANS  
 STA 41+44.00 TO STA 46+04.00  
 SHEET 5 OF 8

DESIGN	CHECKED	DRAWN	PROJECT NO.	SUBMITTAL	SHEET NO.
JC	JC	CDC	23-03763	70%	385

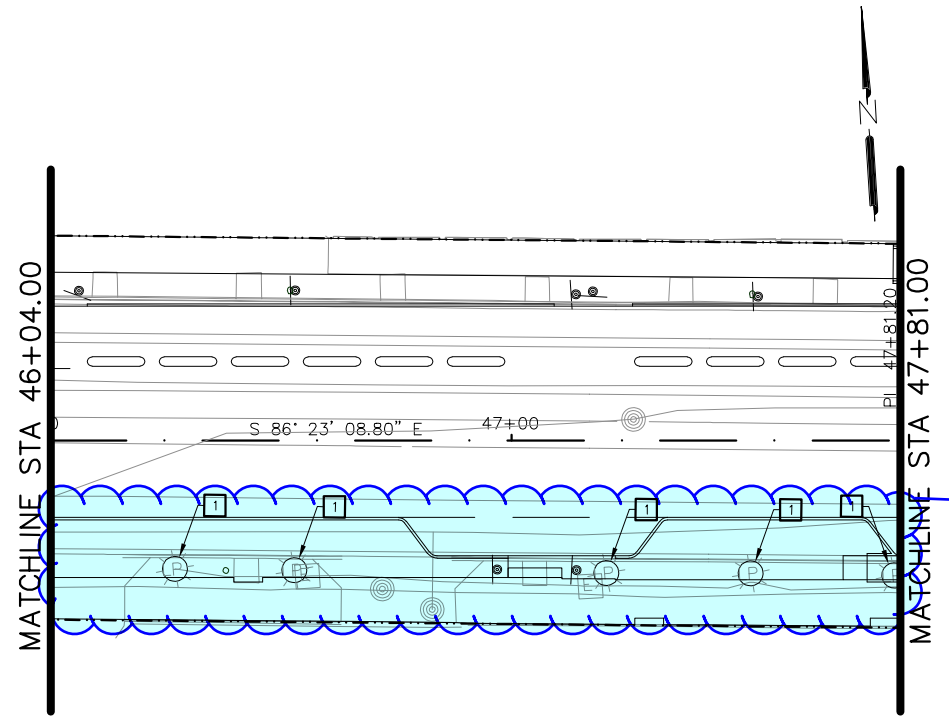

No ped poles salvaged east of Santa Rosa. Several of these are CPS hockey puck style luminaires and will need to be removed by CPS. Review and revise.

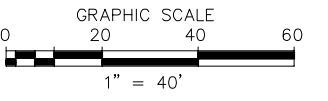

**# DEMO KEYED NOTES: (THIS SHEET ONLY)**

1. REMOVE CITY OWNED LUMINAIRE AND ASSOCIATED CONDUCTORS AND RETURN TO OWNER.

**GENERAL NOTES:**

1. CONTRACTOR TO COORDINATE WITH CPS ENERGY FOR REMOVAL AND RELOCATION OF CPSE EQUIPMENT.
2. PROTECT EXISTING TO REMAIN ELECTRICAL EQUIPMENT AND UNDERGROUND CIRCUITS. REPAIR AND RELOCATE AS NECESSARY TO MAINTAIN OPERATION. ADJUST ASSOCIATED IN-GRADE ELECTRICAL JUNCTION BOX COVER PLATES TO NEW ELEVATION. PROVIDE BOX EXTENSION AS NECESSARY.
3. REFER TO TRAFFIC SIGNAL DRAWINGS FOR TRAFFIC SIGNAL SCOPE OF WORK.

INTERIM REVIEW  
 DOCUMENT INCOMPLETE. NOT INTENDED FOR PERMIT, BIDDING OR CONSTRUCTION.  
 ENGINEER: TRAVIS E. WILTSHIRE  
 P.E. SERIAL NO: 85219  
 COMPANY NAME: CNG ENGINEERING, PLLC.  
 COMPANY REG. NO. F-7964  
 DATE: 01-20-2023

REV. NO.	DATE	DESCRIPTION	BY



**CNG ENGINEERING**  
 MEP DESIGN | PLANNING | COMMISSIONING  
 1917 N NEW BRAUNFELS AVE, SUITE 201  
 SAN ANTONIO, TEXAS 78208  
 T 210.224.8841 F 210.224.8224  
 www.cngengineering.com  
 TBPE FIRM # F-7964



**PAPE-DAWSON ENGINEERS**  
 SAN ANTONIO | AUSTIN | HOUSTON | FORT WORTH | DALLAS  
 2000 NW LOOP 410 | SAN ANTONIO, TX 78218 | 210.875.9000  
 TEXAS ENGINEERING FIRM #170 | TEXAS SURVEYING FIRM #10028800



CITY OF SAN ANTONIO  
**PUBLIC WORKS DEPARTMENT**

DOLOROSA  
 DEMOLITION  
 ELECTRICAL PLANS  
 STA 46+04.00 TO STA 47+81.00  
 SHEET 6 OF 8

DESIGN	CHECKED	DRAWN	PROJECT NO.	SUBMITTAL	SHEET NO.
JC	JC	CDC	23-03763	70%	386



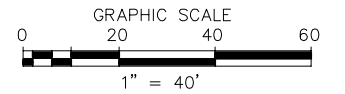
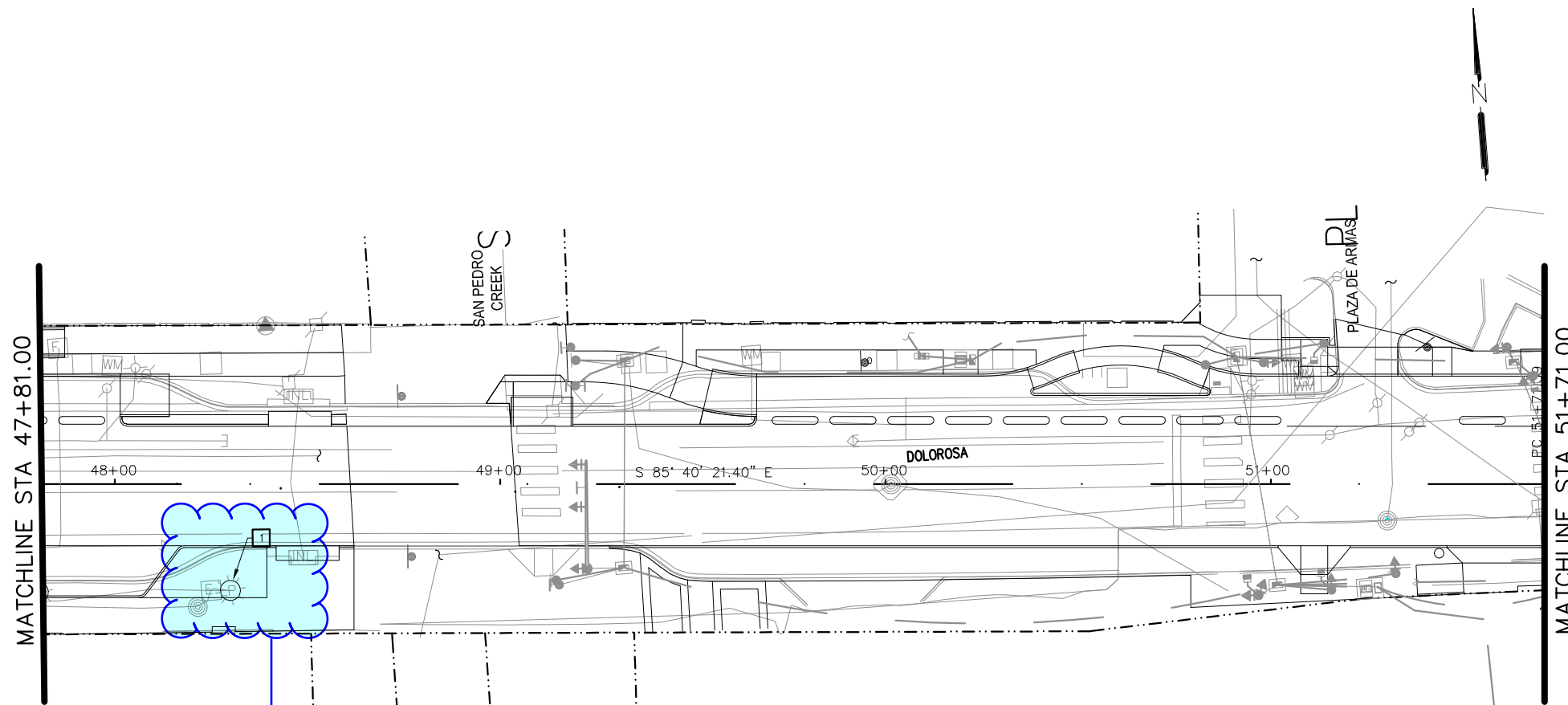

CPS light

**# DEMO KEYED NOTES: (THIS SHEET ONLY)**

1. REMOVE CITY OWNED LUMINAIRE AND ASSOCIATED CONDUCTORS AND RETURN TO OWNER.

**GENERAL NOTES:**

1. CONTRACTOR TO COORDINATE WITH CPS ENERGY FOR REMOVAL AND RELOCATION OF CPSE EQUIPMENT.
2. PROTECT EXISTING TO REMAIN ELECTRICAL EQUIPMENT AND UNDERGROUND CIRCUITS. REPAIR AND RELOCATE AS NECESSARY TO MAINTAIN OPERATION. ADJUST ASSOCIATED IN-GRADE ELECTRICAL JUNCTION BOX COVER PLATES TO NEW ELEVATION. PROVIDE BOX EXTENSION AS NECESSARY.
3. REFER TO TRAFFIC SIGNAL DRAWINGS FOR TRAFFIC SIGNAL SCOPE OF WORK.

INTERIM REVIEW  
 DOCUMENT INCOMPLETE. NOT INTENDED FOR PERMIT, BIDDING OR CONSTRUCTION.  
 ENGINEER: TRAVIS E. WILTSHIRE  
 P.E. SERIAL NO.: 85219  
 COMPANY NAME: CNG ENGINEERING, PLLC.  
 COMPANY REG. NO. F-7964  
 DATE: 01-20-2023

REV. NO.	DATE	DESCRIPTION	BY



**CNG ENGINEERING**  
 MEP DESIGN | PLANNING | COMMISSIONING  
 1917 N NEW BRAUNFELS AVE, SUITE 201  
 SAN ANTONIO, TEXAS 78208  
 T 210.224.8841 F 210.224.8224  
 www.cngengineering.com  
 TBPE FIRM # F-7964



**PAPE-DAWSON ENGINEERS**  
 SAN ANTONIO | AUSTIN | HOUSTON | FORT WORTH | DALLAS  
 2000 NW LOOP 410 | SAN ANTONIO, TX 78218 | 210.875.9000  
 TEXAS ENGINEERING FIRM #170 | TEXAS SURVEYING FIRM #10028800

CITY OF SAN ANTONIO  
**PUBLIC WORKS DEPARTMENT**

DOLOROSA  
**DEMOLITION ELECTRICAL PLANS**  
 STA 47+81.00 TO STA 51+71.00  
 SHEET 7 OF 8

DESIGN	CHECKED	DRAWN	PROJECT NO.	SUBMITTAL	SHEET NO.
JC	JC	CDC	23-03763	70%	387

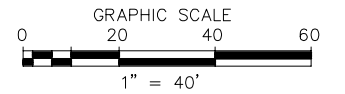
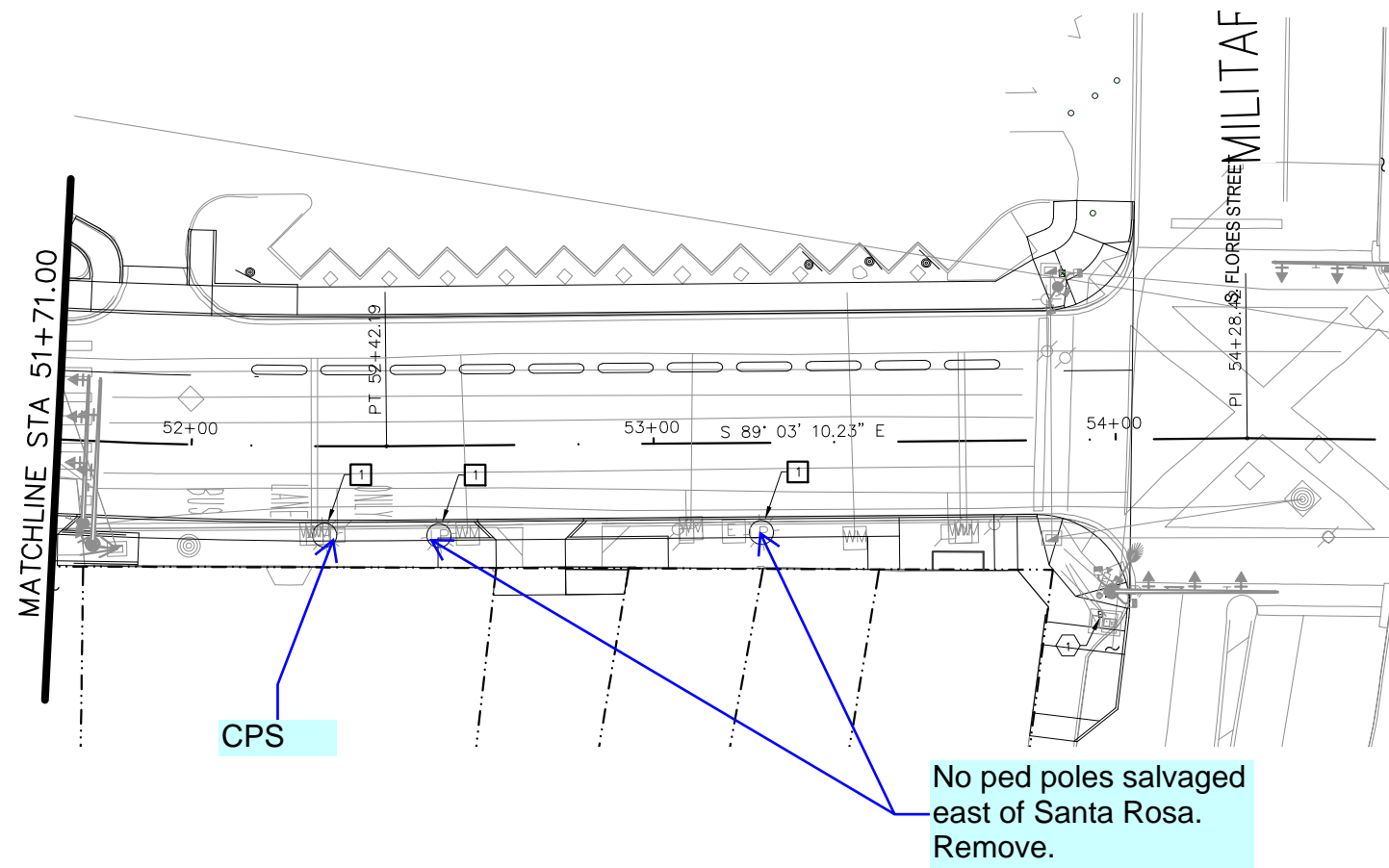

**# KEYED NOTES: (THIS SHEET ONLY)**

1. EXISTING TRAFFIC SIGNAL CABINET. COORDINATE SCOPE OF WORK WITH TRAFFIC SIGNAL DRAWINGS.

**# DEMO KEYED NOTES: (THIS SHEET ONLY)**

1. REMOVE CITY OWNED LUMINAIRE AND ASSOCIATED CONDUCTORS AND RETURN TO OWNER.

**GENERAL NOTES:**

1. CONTRACTOR TO COORDINATE WITH CPS ENERGY FOR REMOVAL AND RELOCATION OF CPSE EQUIPMENT.
2. PROTECT EXISTING TO REMAIN ELECTRICAL EQUIPMENT AND UNDERGROUND CIRCUITS. REPAIR AND RELOCATE AS NECESSARY TO MAINTAIN OPERATION. ADJUST ASSOCIATED IN-GRADE ELECTRICAL JUNCTION BOX COVER PLATES TO NEW ELEVATION. PROVIDE BOX EXTENSION AS NECESSARY.
3. REFER TO TRAFFIC SIGNAL DRAWINGS FOR TRAFFIC SIGNAL SCOPE OF WORK.

No ped poles salvaged east of Santa Rosa. Remove.

INTERIM REVIEW  
 DOCUMENT INCOMPLETE. NOT INTENDED FOR PERMIT, BIDDING OR CONSTRUCTION.  
 ENGINEER: TRAVIS E. WILTSHIRE  
 P.E. SERIAL NO: 85219  
 COMPANY NAME: CNG ENGINEERING, PLLC.  
 COMPANY REG. NO. F-7964  
 DATE: 01-20-2023

REV. NO.	DATE	DESCRIPTION	BY



**CNG ENGINEERING**  
 MEP DESIGN | PLANNING | COMMISSIONING  
 1917 N NEW BRAUNFELS AVE, SUITE 201  
 SAN ANTONIO, TEXAS 78208  
 T 210.224.8841 F 210.224.8224  
 www.cngengineering.com  
 TBPE FIRM # F-7964



**PAPE-DAWSON ENGINEERS**  
 SAN ANTONIO | AUSTIN | HOUSTON | FORT WORTH | DALLAS  
 2000 NW LOOP 410 | SAN ANTONIO, TX 78218 | 210.875.9000  
 TEXAS ENGINEERING FIRM #170 | TEXAS SURVEYING FIRM #10028800

CITY OF SAN ANTONIO  
**PUBLIC WORKS DEPARTMENT**

DOLOROSA  
**DEMOLITION ELECTRICAL PLANS**  
 STA 51+71.00 TO STA 54+29.00  
 SHEET 8 OF 8

DESIGN	CHECKED	DRAWN	PROJECT NO.	SUBMITTAL	SHEET NO.
JC	JC	CDC	23-03763	70%	388

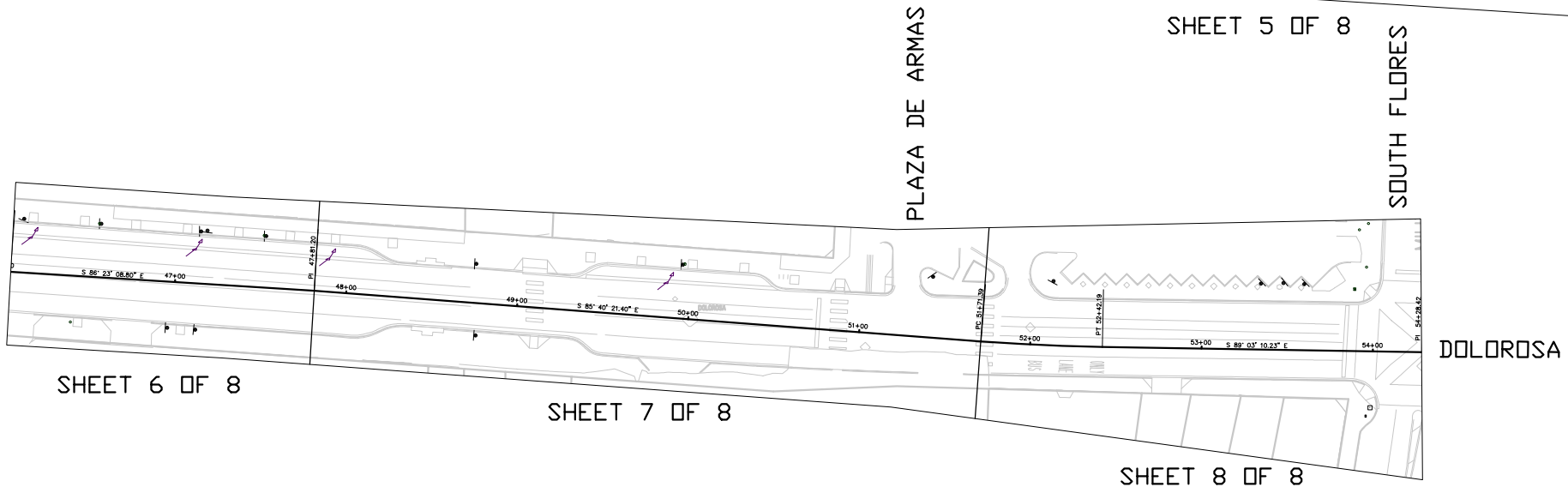
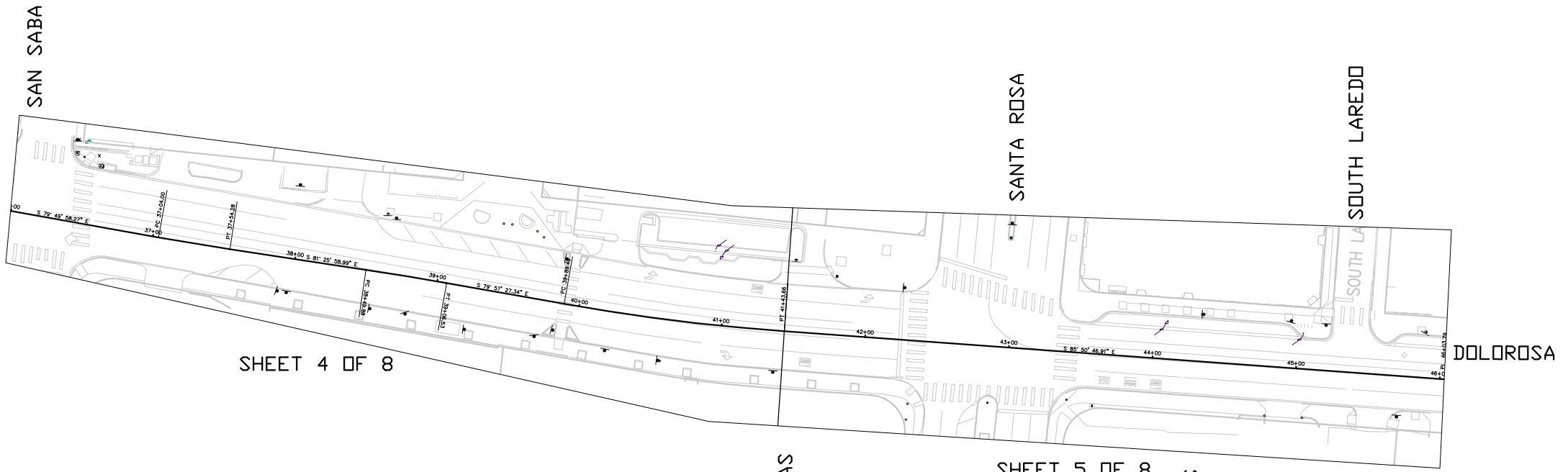
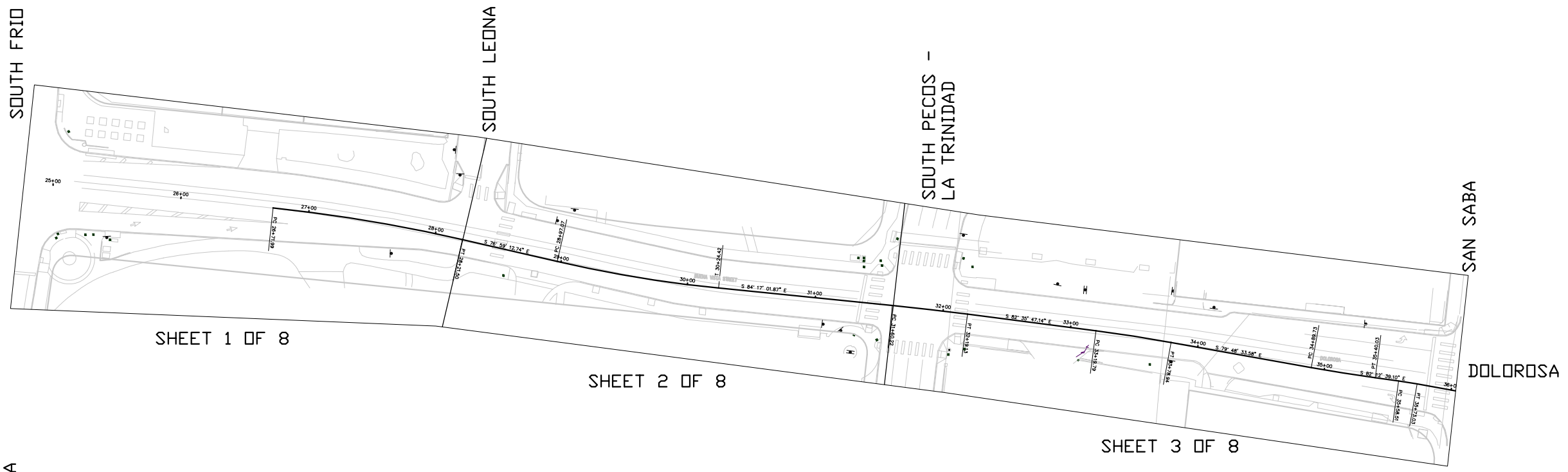

INTERIM REVIEW  
 DOCUMENT INCOMPLETE. NOT INTENDED FOR PERMIT, BIDDING OR CONSTRUCTION.  
 ENGINEER: TRAVIS E. WILTSHIRE  
 P.E. SERIAL NO: 85219  
 COMPANY NAME: CNG ENGINEERING, PLLC.  
 COMPANY REG. NO. F-7964  
 DATE: 01-20-2023

REV. NO.	DATE	DESCRIPTION	BY



**CNG ENGINEERING**  
 MEP DESIGN | PLANNING | COMMISSIONING  
 1917 N NEW BRAUNFELS AVE, SUITE 201  
 SAN ANTONIO, TEXAS 78208  
 T 210.224.8841 F 210.224.8224  
 www.cngengineering.com  
 TBPE FIRM # F-7964



**PAPE-DAWSON ENGINEERS**  
 SAN ANTONIO | AUSTIN | HOUSTON | FORT WORTH | DALLAS  
 2000 NW LOOP 410 | SAN ANTONIO, TX 78218 | 210.375.9000  
 TEXAS ENGINEERING FIRM #170 | TEXAS SURVEYING FIRM #10028800



CITY OF SAN ANTONIO  
**PUBLIC WORKS DEPARTMENT**

DOLOROSA  
 ELECTRICAL SHEET  
 LAYOUT

DESIGN	CHECKED	DRAWN	PROJECT NO.	SUBMITTAL	SHEET NO.
JC	JC	CDC	23-03763	70%	389

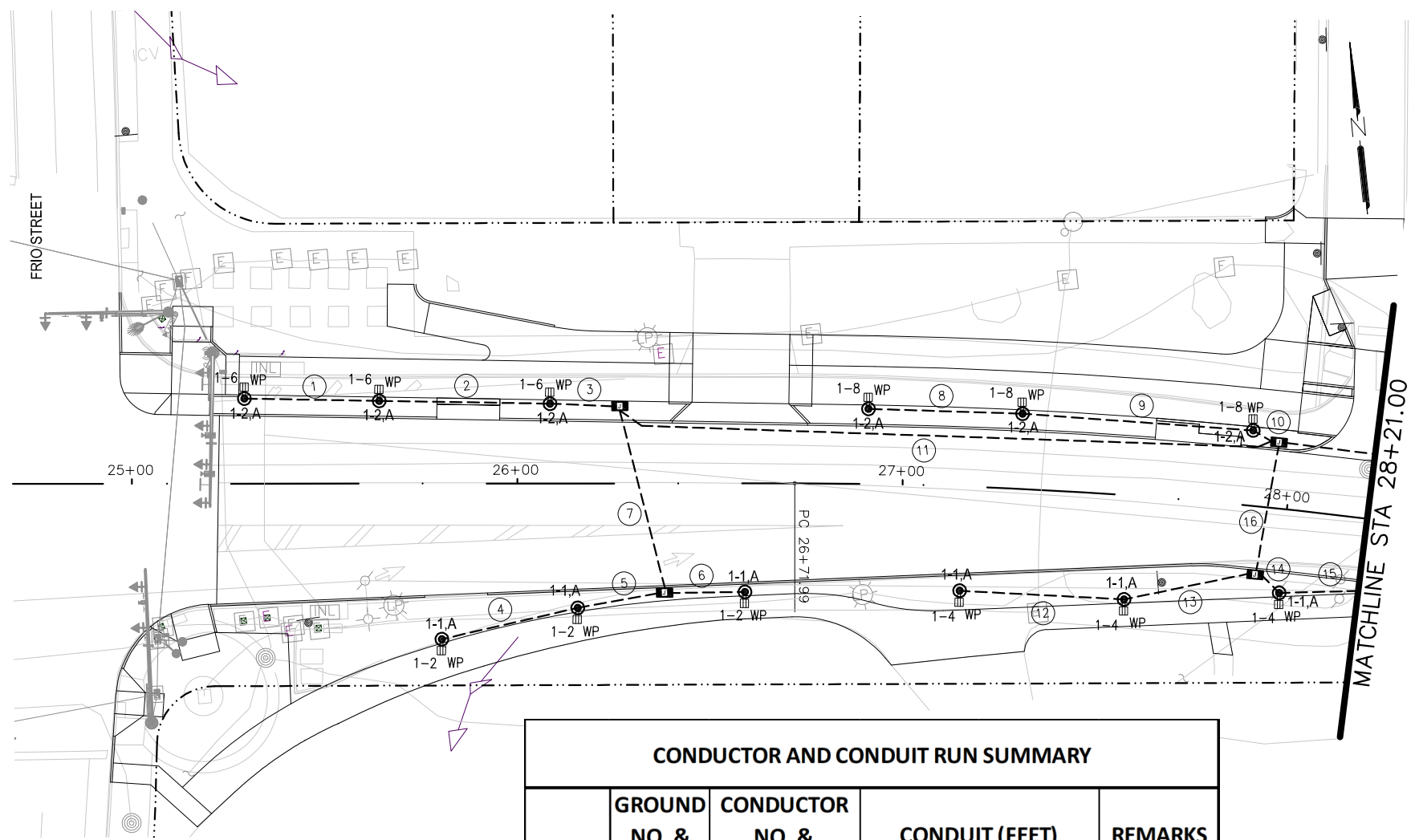

- # KEYED NOTES: (THIS SHEET ONLY)**
- NEW LUMINAIRE POLE MOUNTED AT FINISHED GRADE. (TYPICAL).
- GENERAL NOTES:**
- REFER TO LIGHTING FIXTURE SCHEDULE FOR LUMINAIRE POLE TYPE.
  - COORDINATE U.G. CONDUIT INSTALLATION AROUND DRAINAGE STRUCTURE AND OTHER UTILITIES.
  - PROVIDE #6 CU. WIRING IN 2" PVC CONDUIT UNDERGROUND CIRCUITS FOR ILLUMINATED BOLLARDS, PEDESTRIAN LIGHTING AND POLE MOUNTED RECEPTACLES.
  - SPLICE #10 TO #6 HOME RUN CONDUCTORS AT BASE OF EACH POLE AND RUN CONDUCTORS FROM BASE OF POLE TO POLE MOUNTED RECEPTACLE.

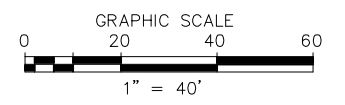
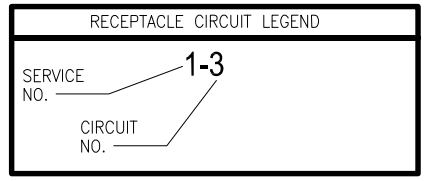
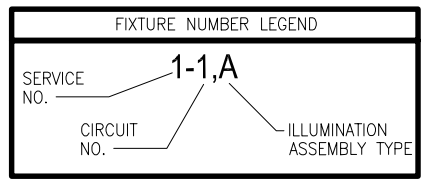

**ILLUMINATION LEGEND**

- PEDESTRIAN LIGHTING POLE
- GFCI RECEPTACLE WITH WHILE-IN-USE COVER
- EXISTING RACEWAY TO REMAIN
- CONDUIT UNDERGROUND OR CAST IN STRUCTURE WITH CONDUCTORS. SEE SUMMARY.
- GROUND BOX WITH CONC. APRON
- ELECTRIC SERVICE/POLE #NUMBER
- CONDUIT RUN NUMBER
- POWER POLE

CONDUCTOR AND CONDUIT RUN SUMMARY					
RUN NO	GROUND NO. & LENGTH (FEET)	CONDUCTOR NO. & LENGTH (FEET)	CONDUIT (FEET)		REMARKS
			SCH 40	SCH 40	
	#6 BARE	#6 INSULATED	PVC 2"	PVC 1"	
1	47	188		41	
2	57	228		51	
3	30	120		24	
4	49	196		43	
5	35	140		29	
6	33	132		27	
7	62	248		56	
8	52	208		46	
9	72	288		66	
10	20	80		14	
11	184	1104	178		
12	55	220		49	
13	47	188		41	
14	20	80		14	
15	42	168		36	
16	47	188	41		
<b>TOTALS</b>	<b>313</b>	<b>1252</b>	<b>0</b>	<b>271</b>	

COSA PM team will need to see a roll plot drawing or digital file with all utilities, trees, and light pole foundations. I need to see this before proceeding to 95% design. I cannot make comments on planting or illumination layouts without seeing how underground conflicts will impact what is proposed.

**INTERIM REVIEW**

DOCUMENT INCOMPLETE. NOT INTENDED FOR PERMIT, BIDDING OR CONSTRUCTION.

ENGINEER: TRAVIS E. WILTSHIRE

P.E. SERIAL NO: 85219

COMPANY NAME: CNG ENGINEERING, PLLC.

COMPANY REG. NO. F-7964

DATE: 01-20-2023

REV. NO.	DATE	DESCRIPTION	BY

**CNG ENGINEERING**  
 MEP DESIGN | PLANNING | COMMISSIONING  
 1917 N NEW BRAUNFELS AVE, SUITE 201  
 SAN ANTONIO, TEXAS 78208  
 T 210.224.8841 F 210.224.8224  
 www.cngengineering.com  
 TBPE FIRM # F-7964

**PAPE-DAWSON ENGINEERS**  
 SAN ANTONIO | AUSTIN | HOUSTON | FORT WORTH | DALLAS  
 2000 NW LOOP 410 | SAN ANTONIO, TX 78218 | 210.375.9000  
 TEXAS ENGINEERING FIRM #170 | TEXAS SURVEYING FIRM #10028800

CITY OF SAN ANTONIO  
**PUBLIC WORKS DEPARTMENT**

DOLOROSA  
**ELECTRICAL PLANS**

STA BEGIN TO STA 28+21.00

SHEET 1 OF 8

DESIGN	CHECKED	DRAWN	PROJECT NO.	SUBMITTAL	SHEET NO.
JC	JC	CDC	23-03763	70%	390

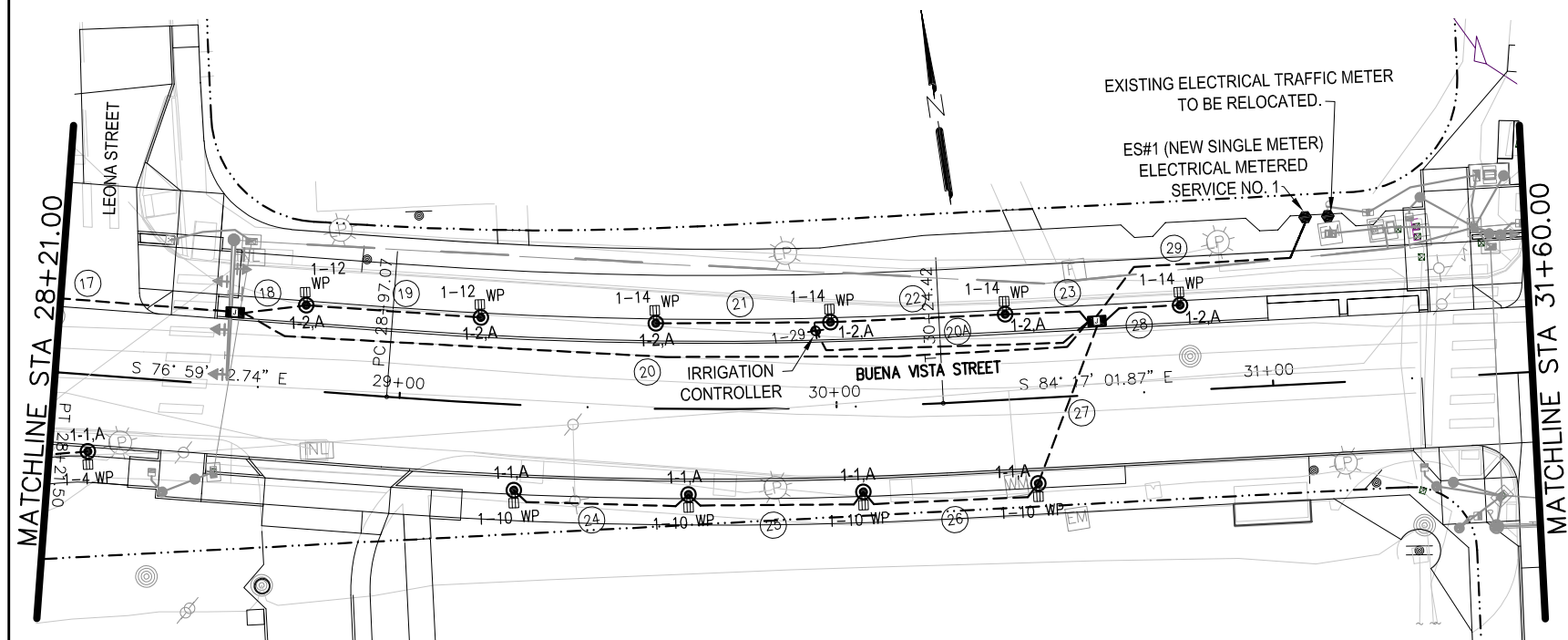

- KEYED NOTES: (THIS SHEET ONLY)**
- NEW LUMINAIRE POLE MOUNTED AT FINISHED GRADE. (TYPICAL).
- GENERAL NOTES:**
- REFER TO LIGHTING FIXTURE SCHEDULE FOR LUMINAIRE POLE TYPE.
  - COORDINATE U.G. CONDUIT INSTALLATION AROUND DRAINAGE STRUCTURE AND OTHER UTILITIES.
  - PROVIDE #6 CU. WIRING IN 2" PVC CONDUIT UNDERGROUND CIRCUITS FOR ILLUMINATED BOLLARDS, PEDESTRIAN LIGHTING AND POLE MOUNTED RECEPTACLES.
  - SPLICE #10 TO #6 HOME RUN CONDUCTORS AT BASE OF EACH POLE AND RUN CONDUCTORS FROM BASE OF POLE TO POLE MOUNTED RECEPTACLE.

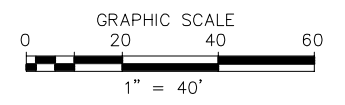
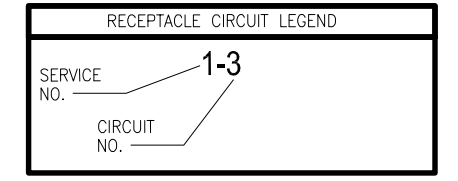
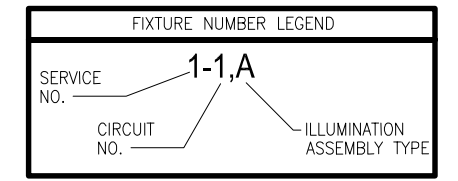

**ILLUMINATION LEGEND**

- PEDESTRIAN LIGHTING POLE
- GFCI RECEPTACLE WITH WHILE-IN-USE COVER
- EXISTING RACEWAY TO REMAIN
- CONDUIT UNDERGROUND OR CAST IN STRUCTURE WITH CONDUCTORS. SEE SUMMARY.
- GROUND BOX WITH CONC. APRON
- ELECTRIC SERVICE/POLE #NUMBER
- CONDUIT RUN NUMBER
- POWER POLE

CONDUCTOR AND CONDUIT RUN SUMMARY					
RUN NO	GROUND NO. & LENGTH	CONDUCTOR NO. & LENGTH	CONDUIT (FEET)		REMARKS
	(FEET)	(FEET)	SCH 40	SCH 40	
	#6 BARE	#6 INSULATED	PVC 2"	PVC 1"	
17	77	770	71		
18	28	112		22	
19	52	208		46	
20	212	2968	206		
20A	53	106		47	
21	52	208		46	
22	52	208		46	
23	34	136		28	
24	53	212		47	
25	53	212		47	
26	53	212		47	
27	52	208	46		
28	32	128		26	
29	72	1296	66	66	
<b>TOTALS</b>	<b>875</b>	<b>6984</b>	<b>389</b>	<b>468</b>	

**INTERIM REVIEW**

DOCUMENT INCOMPLETE. NOT INTENDED FOR PERMIT, BIDDING OR CONSTRUCTION.

ENGINEER: TRAVIS E. WILTSHIRE

P.E. SERIAL NO: 85219

COMPANY NAME: CNG ENGINEERING, PLLC.

COMPANY REG. NO. F-7964

DATE: 01-20-2023

REV. NO.	DATE	DESCRIPTION	BY

**CNG ENGINEERING**  
MEP DESIGN | PLANNING | COMMISSIONING  
1917 N NEW BRAUNFELS AVE, SUITE 201  
SAN ANTONIO, TEXAS 78208  
T 210.224.8841 F 210.224.8224  
www.cngengineering.com  
TBPE FIRM # F-7964

**PAPE-DAWSON ENGINEERS**  
SAN ANTONIO | AUSTIN | HOUSTON | FORT WORTH | DALLAS  
2000 NW LOOP 410 | SAN ANTONIO, TX 78218 | 210.875.9000  
TEXAS ENGINEERING FIRM #170 | TEXAS SURVEYING FIRM #10028800

CITY OF SAN ANTONIO  
**PUBLIC WORKS DEPARTMENT**

DOLOROSA  
**ELECTRICAL PLANS**

STA 28+21.00 STA 31+60.00  
SHEET 2 OF 8

DESIGN	CHECKED	DRAWN	PROJECT NO.	SUBMITTAL	SHEET NO.
JC	JC	CDC	23-03763	70%	391

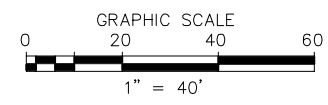
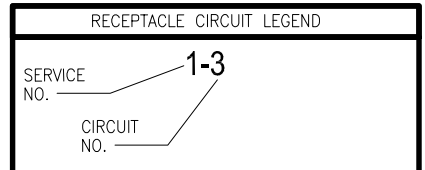
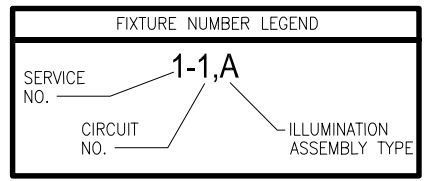
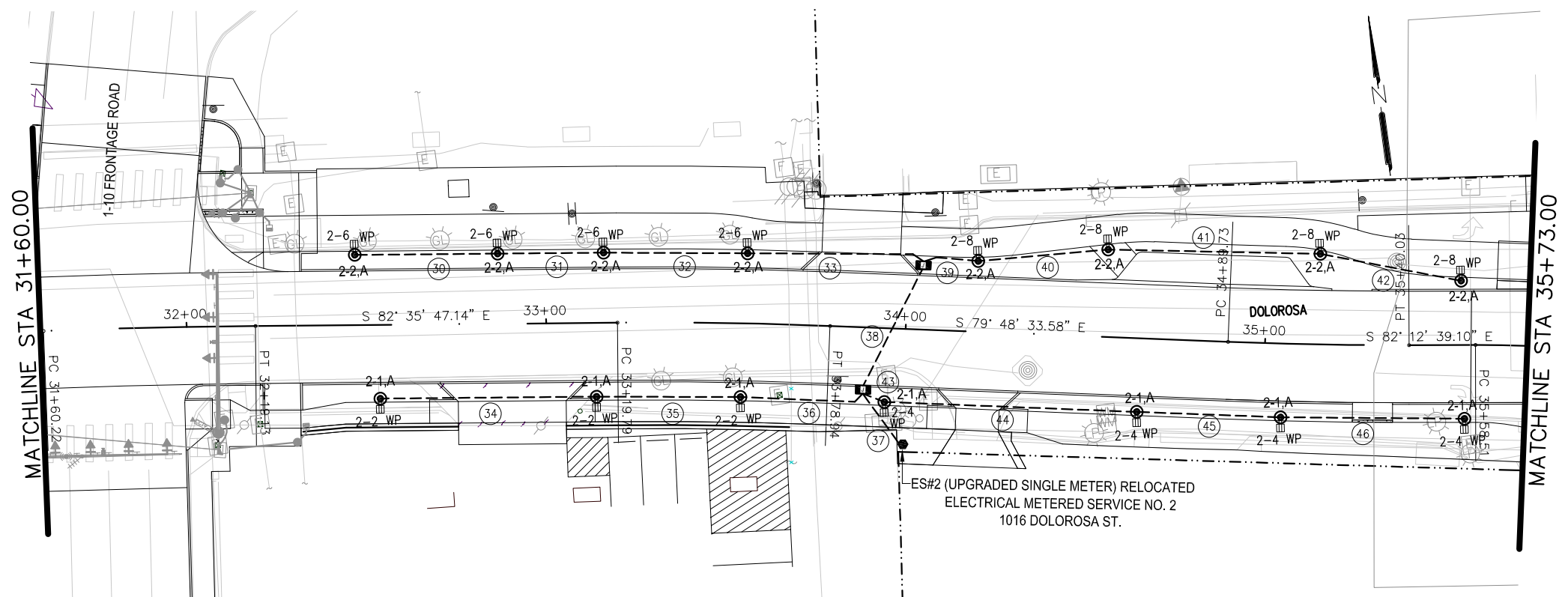

**KEYED NOTES: (THIS SHEET ONLY)**

- NEW LUMINAIRE POLE MOUNTED AT FINISHED GRADE. (TYPICAL).

**GENERAL NOTES:**

- REFER TO LIGHTING FIXTURE SCHEDULE FOR LUMINAIRE POLE TYPE.
- COORDINATE U.G. CONDUIT INSTALLATION AROUND DRAINAGE STRUCTURE AND OTHER UTILITIES.
- PROVIDE #6 CU. WIRING IN 2" PVC CONDUIT UNDERGROUND CIRCUITS FOR ILLUMINATED BOLLARDS, PEDESTRIAN LIGHTING AND POLE MOUNTED RECEPTACLES.
- SPLICE #10 TO #6 HOME RUN CONDUCTORS AT BASE OF EACH POLE AND RUN CONDUCTORS FROM BASE OF POLE TO POLE MOUNTED RECEPTACLE.

**CONDUCTOR AND CONDUIT RUN SUMMARY**

RUN NO	GROUND NO. & LENGTH (FEET)	CONDUCTOR NO. & LENGTH (FEET)	CONDUIT (FEET)		REMARKS
	#6 BARE	#6 INSULATED	SCH 40	SCH 40	
			PVC 2"	PVC 1"	
30	52	208		46	
31	42	168		36	
32	54	216		48	
33	62	248		56	
34	73	292		67	
35	53	212		47	
36	48	192		42	
37	34	408	28		
38	53	318	47		
39	28	112		22	
40	62	248		56	
41	58	232		52	
42	53	212		47	
43	20	80		14	
44	83	332		77	
45	53	212		47	
46	65	260		59	
TOTALS	893	3950	75	716	

**ILLUMINATION LEGEND**

- PEDESTRIAN LIGHTING POLE
- GFCI RECEPTACLE WITH WHILE-IN-USE COVER
- EXISTING RACEWAY TO REMAIN
- CONDUIT UNDERGROUND OR CAST IN STRUCTURE WITH CONDUCTORS. SEE SUMMARY.
- GROUND BOX WITH CONC. APRON
- ELECTRIC SERVICE/POLE #NUMBER
- CONDUIT RUN NUMBER
- POWER POLE

**INTERIM REVIEW**  
 DOCUMENT INCOMPLETE. NOT INTENDED FOR PERMIT, BIDDING OR CONSTRUCTION.  
 ENGINEER: TRAVIS E. WILTSHIRE  
 P.E. SERIAL NO: 85219  
 COMPANY NAME: CNG ENGINEERING, PLLC.  
 COMPANY REG. NO. F-7964  
 DATE: 01-20-2023

REV. NO.	DATE	DESCRIPTION	BY

**CNG ENGINEERING**  
 MEP DESIGN | PLANNING | COMMISSIONING  
 1917 N NEW BRAUNFELS AVE, SUITE 201  
 SAN ANTONIO, TEXAS 78208  
 T 210.224.8841 F 210.224.8224  
 www.cngengineering.com  
 TBPE FIRM # F-7964

**PAPE-DAWSON ENGINEERS**  
 SAN ANTONIO | AUSTIN | HOUSTON | FORT WORTH | DALLAS  
 2000 NW LOOP 410 | SAN ANTONIO, TX 78218 | 210.875.9000  
 TEXAS ENGINEERING FIRM #170 | TEXAS SURVEYING FIRM #10028800

CITY OF SAN ANTONIO  
**PUBLIC WORKS DEPARTMENT**

DOLOROSA  
**ELECTRICAL PLANS**  
 STA 31+60.00 TO STA 35+73.00

DESIGN	CHECKED	DRAWN	PROJECT NO.	SUBMITTAL	SHEET NO.
JC	JC	CDC	23-03763	70%	392

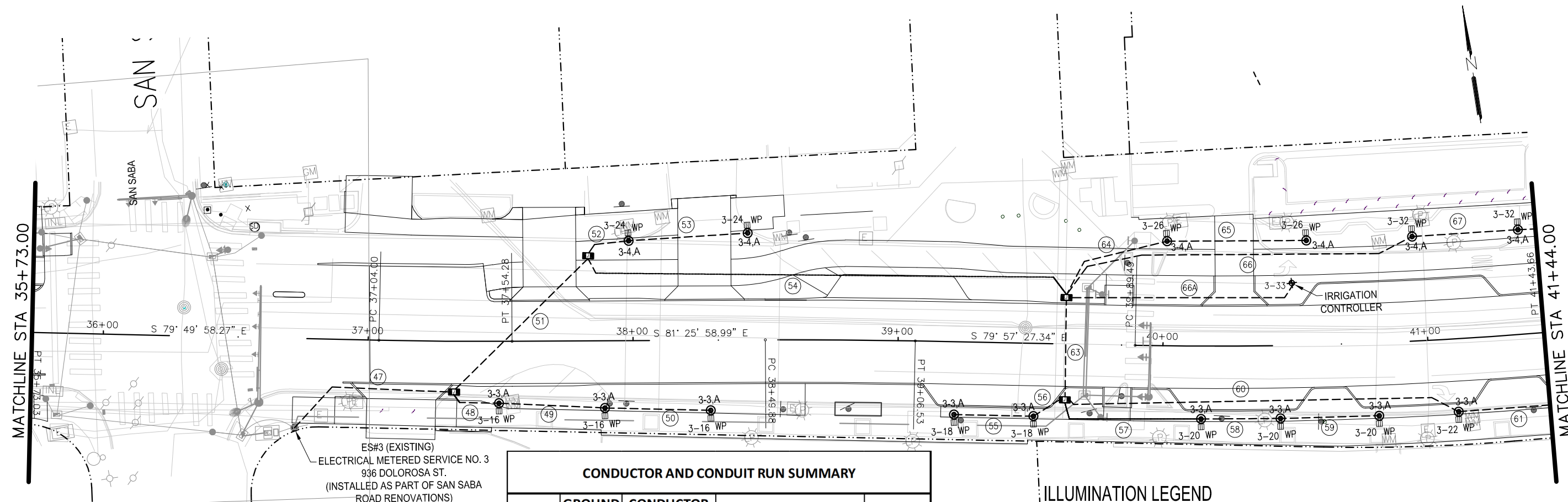

**KEYED NOTES: (THIS SHEET ONLY)**

- NEW LUMINAIRE POLE MOUNTED AT FINISHED GRADE. (TYPICAL).

**GENERAL NOTES:**

- REFER TO LIGHTING FIXTURE SCHEDULE FOR LUMINAIRE POLE TYPE.
- COORDINATE U.G. CONDUIT INSTALLATION AROUND DRAINAGE STRUCTURE AND OTHER UTILITIES.
- PROVIDE #6 CU. WIRING IN 2" PVC CONDUIT UNDERGROUND CIRCUITS FOR ILLUMINATED BOLLARDS, PEDESTRIAN LIGHTING AND POLE MOUNTED RECEPTACLES.
- SPLICE #10 TO #6 HOME RUN CONDUCTORS AT BASE OF EACH POLE AND RUN CONDUCTORS FROM BASE OF POLE TO POLE MOUNTED RECEPTACLE.

ES#3 (EXISTING)  
ELECTRICAL METERED SERVICE NO. 3  
936 DOLOROSA ST.  
(INSTALLED AS PART OF SAN SABA  
ROAD RENOVATIONS)

CONDUCTOR AND CONDUIT RUN SUMMARY					
RUN NO	GROUND NO. & LENGTH (FEET)	CONDUCTOR NO. & LENGTH (FEET)	CONDUIT (FEET)		REMARKS
			SCH 40	SCH 40	
	#6 BARE	#6 INSULATED	PVC 2"	PVC 1"	
47	78	1560	72		
48	31	124		25	
49	53	212		47	
50	53	212		47	
51	84	1512	78	78	
52	29	116		23	
53	58	232		52	
54	202	3232	196		
55	43	172		37	
56	27	108		21	
57	67	268		61	
58	43	172		37	
59	50	200		44	
60	162	648		156	
61	57	228		51	
63	53	424	47	47	
64	57	228		51	
65	65	260		59	
66A	98	196		92	
67	52	208		46	
<b>TOTALS</b>	<b>1509</b>	<b>10900</b>	<b>393</b>	<b>1115</b>	

**ILLUMINATION LEGEND**

- PEDESTRIAN LIGHTING POLE
- GFCI RECEPTACLE WITH WHILE-IN-USE COVER
- EXISTING RACEWAY TO REMAIN
- CONDUIT UNDERGROUND OR CAST IN STRUCTURE WITH CONDUCTORS. SEE SUMMARY.
- GROUND BOX WITH CONC. APRON
- ELECTRIC SERVICE/POLE #NUMBER
- CONDUIT RUN NUMBER

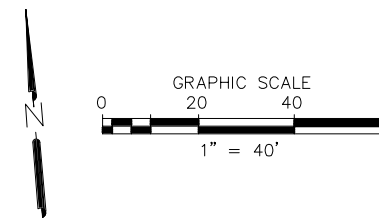
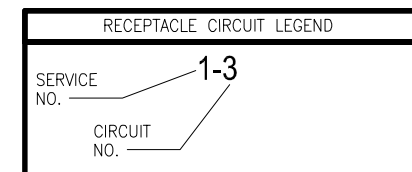
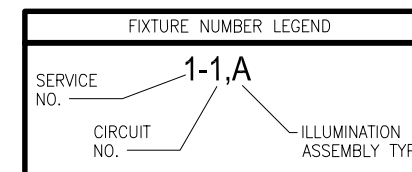

INTERIM REVIEW  
DOCUMENT INCOMPLETE. NOT INTENDED FOR PERMIT, BIDDING OR CONSTRUCTION.  
ENGINEER: TRAVIS E. WILTSHIRE  
P.E. SERIAL NO: 85219  
COMPANY NAME: CNG ENGINEERING, PLLC.  
COMPANY REG. NO. F-7964  
DATE: 01-20-2023

REV. NO.	DATE	DESCRIPTION	BY

**CNG ENGINEERING**  
MEP DESIGN | PLANNING | COMMISSIONING  
1917 N NEW BRAUNFELS AVE, SUITE 201  
SAN ANTONIO, TEXAS 78208  
T 210.224.8841 F 210.224.8224  
www.cngengineering.com  
TBPE FIRM # F-7964

**PAPE-DAWSON ENGINEERS**  
SAN ANTONIO | AUSTIN | HOUSTON | FORT WORTH | DALLAS  
2000 NW LOOP 410 | SAN ANTONIO, TX 78218 | 210.875.9000  
TEXAS ENGINEERING FIRM #170 | TEXAS SURVEYING FIRM #10028800

CITY OF SAN ANTONIO  
**PUBLIC WORKS DEPARTMENT**

DOLOROSA  
**ELECTRICAL PLANS**  
STA 35+73.00 TO STA 41+44.00  
SHEET 4 OF 8

DESIGN	CHECKED	DRAWN	PROJECT NO.	SUBMITTAL	SHEET NO.
JC	JC	CDC	23-03763	70%	393

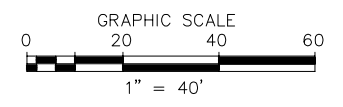
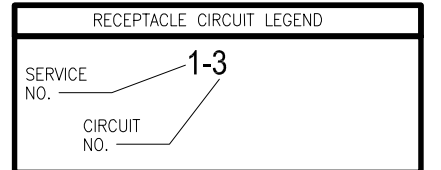
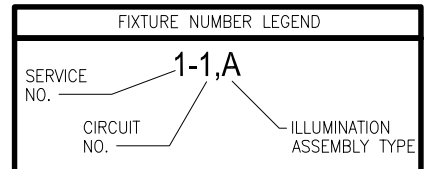
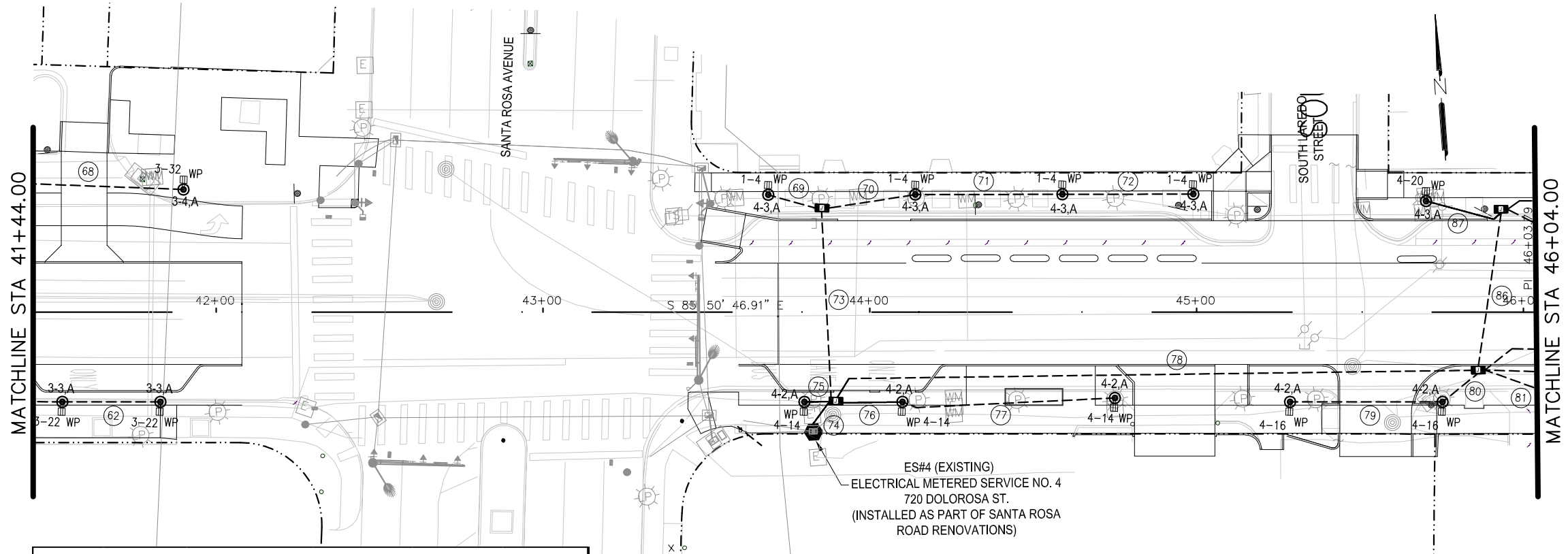

CONDUCTOR AND CONDUIT RUN SUMMARY					
RUN NO	GROUND NO. & LENGTH	CONDUCTOR NO. & LENGTH	CONDUIT (FEET)		REMARKS
	(FEET)	(FEET)	SCH 40	SCH 40	
	#6 BARE	#6 INSULATED	PVC 2"	PVC 1"	
62	43	172		37	
68	65	260		59	
69	30	120		24	
70	42	168		36	
71	58	232		52	
72	52	208		46	
73	74	296	68		
74	27	486	21		
75	22	88		16	
76	34	136		28	
77	77	308		71	
78	224	3136	218		
79	59	236		53	
80	26	104		20	
81	43	172		37	
86	63	378	57		
87	36	144		30	
TOTALS	975	6644	364	509	

- KEYED NOTES: (THIS SHEET ONLY)**
- NEW LUMINAIRE POLE MOUNTED AT FINISHED GRADE. (TYPICAL).
- GENERAL NOTES:**
- REFER TO LIGHTING FIXTURE SCHEDULE FOR LUMINAIRE POLE TYPE.
  - COORDINATE U.G. CONDUIT INSTALLATION AROUND DRAINAGE STRUCTURE AND OTHER UTILITIES.
  - PROVIDE #6 CU. WIRING IN 2" PVC CONDUIT UNDERGROUND CIRCUITS FOR ILLUMINATED BOLLARDS, PEDESTRIAN LIGHTING AND POLE MOUNTED RECEPTACLES.
  - SPLICE #10 TO #6 HOME RUN CONDUCTORS AT BASE OF EACH POLE AND RUN CONDUCTORS FROM BASE OF POLE TO POLE MOUNTED RECEPTACLE.

**ILLUMINATION LEGEND**

- PEDESTRIAN LIGHTING POLE
- GFCI RECEPTACLE WITH WHILE-IN-USE COVER
- EXISTING RACEWAY TO REMAIN
- CONDUIT UNDERGROUND OR CAST IN STRUCTURE WITH CONDUCTORS. SEE SUMMARY.
- GROUND BOX WITH CONC. APRON
- ELECTRIC SERVICE/POLE #NUMBER
- CONDUIT RUN NUMBER

INTERIM REVIEW

DOCUMENT INCOMPLETE. NOT INTENDED FOR PERMIT, BIDDING OR CONSTRUCTION.

ENGINEER: TRAVIS E. WILTSHIRE

P.E. SERIAL NO: 85219

COMPANY NAME: CNG ENGINEERING, PLLC.

COMPANY REG. NO. F-7964

DATE: 01-20-2023

REV. NO.	DATE	DESCRIPTION	BY

**CNG ENGINEERING**  
MEP DESIGN | PLANNING | COMMISSIONING

1917 N NEW BRAUNFELS AVE, SUITE 201  
SAN ANTONIO, TEXAS 78208  
T 210.224.8841 F 210.224.8224  
www.cngengineering.com  
TBPE FIRM # F-7964

**PAPE-DAWSON ENGINEERS**

SAN ANTONIO | AUSTIN | HOUSTON | FORT WORTH | DALLAS  
2000 NW LOOP 410 | SAN ANTONIO, TX 78218 | 210.875.9000  
TEXAS ENGINEERING FIRM #170 | TEXAS SURVEYING FIRM #10028800

CITY OF SAN ANTONIO  
**PUBLIC WORKS DEPARTMENT**

DOLOROSA  
**ELECTRICAL PLANS**

STA 41+44.00 TO STA 46+04.00

SHEET 5 OF 8

DESIGN	CHECKED	DRAWN	PROJECT NO.	SUBMITTAL	SHEET NO.
JC	JC	CDC	23-03763	70%	394



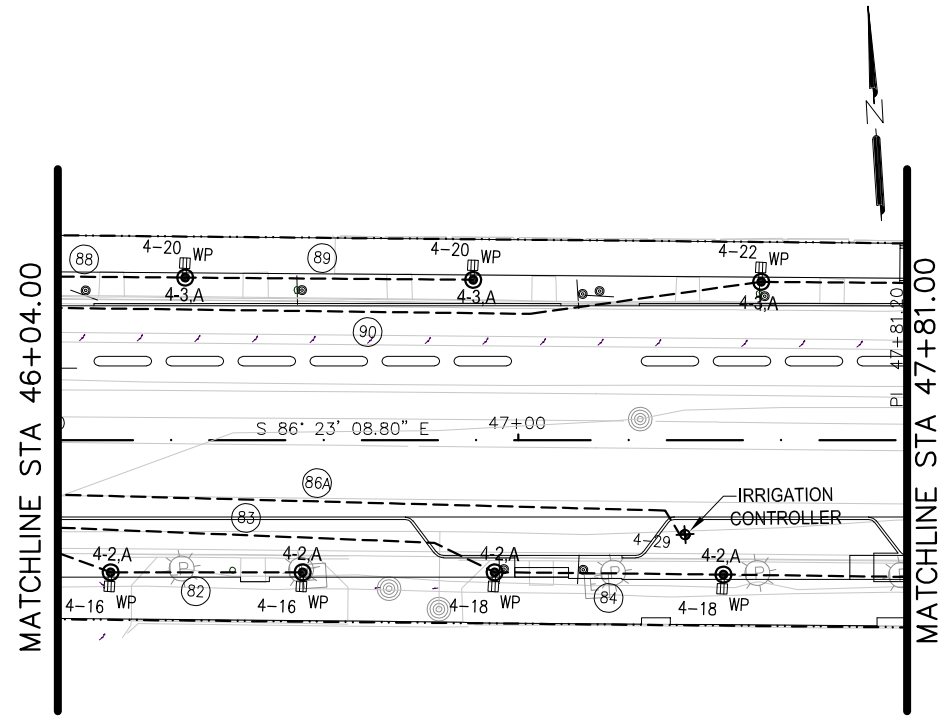

**# KEYED NOTES: (THIS SHEET ONLY)**

1. NEW LUMINAIRE POLE MOUNTED AT FINISHED GRADE. (TYPICAL).

**GENERAL NOTES:**

- REFER TO LIGHTING FIXTURE SCHEDULE FOR LUMINAIRE POLE TYPE.
- COORDINATE U.G. CONDUIT INSTALLATION AROUND DRAINAGE STRUCTURE AND OTHER UTILITIES.
- PROVIDE #6 CU. WIRING IN 2" PVC CONDUIT UNDERGROUND CIRCUITS FOR ILLUMINATED BOLLARDS, PEDESTRIAN LIGHTING AND POLE MOUNTED RECEPTACLES.
- SPLICE #10 TO #6 HOME RUN CONDUCTORS AT BASE OF EACH POLE AND RUN CONDUCTORS FROM BASE OF POLE TO POLE MOUNTED RECEPTACLE.

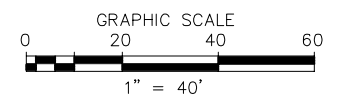
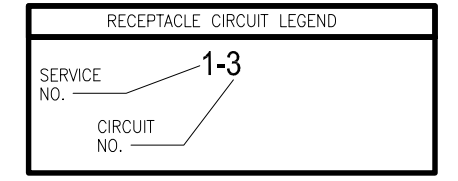
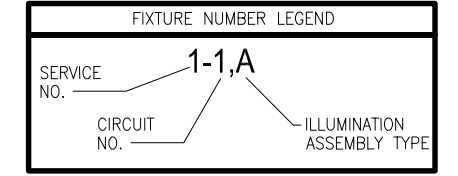

**ILLUMINATION LEGEND**

- PEDESTRIAN LIGHTING POLE
- GFCI RECEPTACLE WITH WHILE-IN-USE COVER
- EXISTING RACEWAY TO REMAIN
- CONDUIT UNDERGROUND OR CAST IN STRUCTURE WITH CONDUCTORS. SEE SUMMARY.
- GROUND BOX WITH CONC. APRON
- ELECTRIC SERVICE/POLE #NUMBER
- CONDUIT RUN NUMBER
- POWER POLE

CONDUCTOR AND CONDUIT RUN SUMMARY					
RUN NO	GROUND NO. & LENGTH	CONDUCTOR NO. & LENGTH	CONDUIT (FEET)		REMARKS
	(FEET)	(FEET)	SCH 40	SCH 40	
	#6 BARE	#6 INSULATED	PVC 2"	PVC 1"	
82	47	188		47	
83	118	472		118	
84	54	216		54	
86A	161	322		161	
88	43	172		43	
89	67	268		67	
90	166	664		166	
TOTALS	656	2302	0	656	

INTERIM REVIEW  
 DOCUMENT INCOMPLETE. NOT INTENDED FOR PERMIT, BIDDING OR CONSTRUCTION.  
 ENGINEER: TRAVIS E. WILTSHIRE  
 P.E. SERIAL NO: 85219  
 COMPANY NAME: CNG ENGINEERING, PLLC.  
 COMPANY REG. NO. F-7964  
 DATE: 01-20-2023

REV. NO.	DATE	DESCRIPTION	BY

**CNG ENGINEERING**  
 MEP DESIGN | PLANNING | COMMISSIONING  
 1917 N NEW BRAUNFELS AVE, SUITE 201  
 SAN ANTONIO, TEXAS 78208  
 T 210.224.8841 F 210.224.8224  
 www.cngengineering.com  
 TBPE FIRM # F-7964

**PAPE-DAWSON ENGINEERS**  
 SAN ANTONIO | AUSTIN | HOUSTON | FORT WORTH | DALLAS  
 2000 NW LOOP 410 | SAN ANTONIO, TX 78218 | 210.875.9000  
 TEXAS ENGINEERING FIRM #170 | TEXAS SURVEYING FIRM #10028800

CITY OF SAN ANTONIO  
**PUBLIC WORKS DEPARTMENT**

DOLOROSA  
**ELECTRICAL PLANS**  
 STA 46+04.00 TO STA 47+81.00  
 SHEET 6 OF 8

DESIGN	CHECKED	DRAWN	PROJECT NO.	SUBMITTAL	SHEET NO.
JC	JC	CDC	23-03763	70%	395

FIXTURE NUMBER LEGEND		
SERVICE NO.	1-1,A	ILLUMINATION ASSEMBLY TYPE
CIRCUIT NO.		

RECEPTACLE CIRCUIT LEGEND		
SERVICE NO.	1-3	CIRCUIT NO.
CIRCUIT NO.		

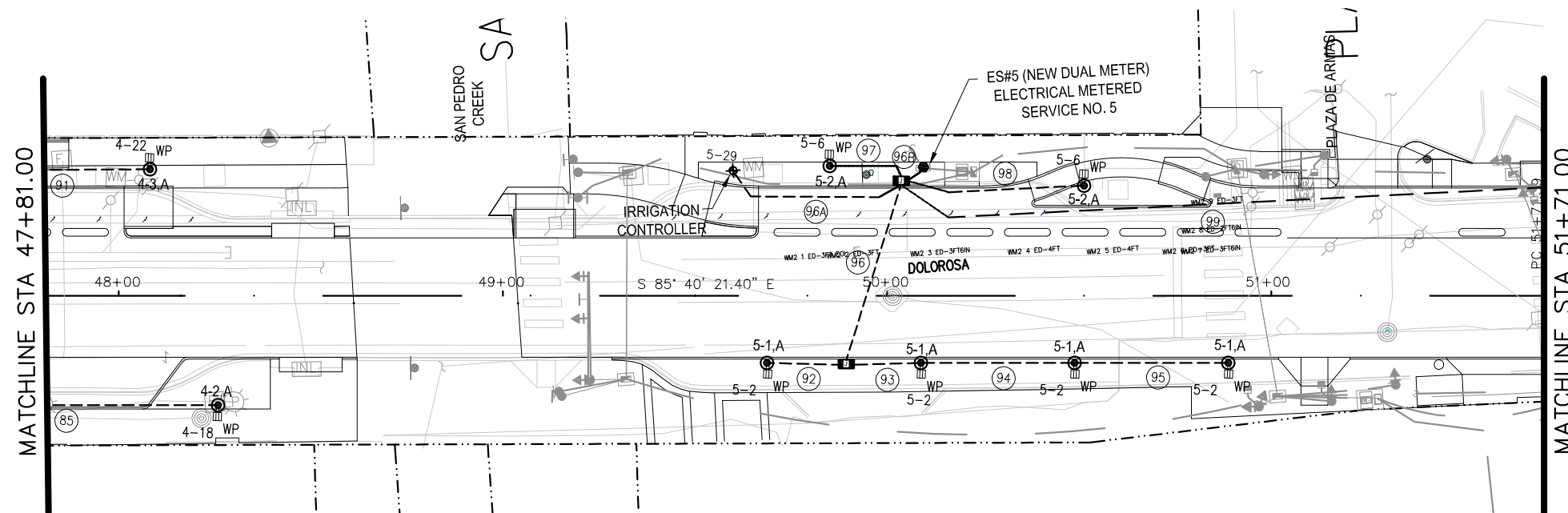
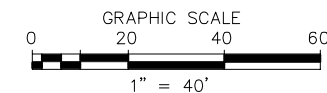

CONDUCTOR AND CONDUIT RUN SUMMARY					
RUN NO	GROUND NO. & LENGTH (FEET)	CONDUCTOR NO. & LENGTH (FEET)	CONDUIT (FEET)		REMARKS
			SCH 40	SCH 40	
	#6 BARE	#6 INSULATED	PVC 2"	PVC 1"	
85	96	384		90	
91	72	288		66	
92	34	136		28	
93	32	128		26	
94	53	212		47	
95	53	212		47	
96	64	256	58		
96A	57	114		51	
96B	22	264	16		
97	34	68		28	
98	60	120		54	
99	262	2096	256		
<b>TOTALS</b>	<b>839</b>	<b>4278</b>	<b>330</b>	<b>437</b>	

# KEYED NOTES: (THIS SHEET ONLY)

- NEW LUMINAIRE POLE MOUNTED AT FINISHED GRADE. (TYPICAL).

GENERAL NOTES:

- REFER TO LIGHTING FIXTURE SCHEDULE FOR LUMINAIRE POLE TYPE.
- COORDINATE U.G. CONDUIT INSTALLATION AROUND DRAINAGE STRUCTURE AND OTHER UTILITIES.
- PROVIDE #6 CU. WIRING IN 2" PVC CONDUIT UNDERGROUND CIRCUITS FOR ILLUMINATED BOLLARDS, PEDESTRIAN LIGHTING AND POLE MOUNTED RECEPTACLES.
- SPLICE #10 TO #6 HOME RUN CONDUCTORS AT BASE OF EACH POLE AND RUN CONDUCTORS FROM BASE OF POLE TO POLE MOUNTED RECEPTACLE.

ILLUMINATION LEGEND

- PEDESTRIAN LIGHTING POLE
- GFCI RECEPTACLE WITH WHILE-IN-USE COVER
- EXISTING RACEWAY TO REMAIN
- CONDUIT UNDERGROUND OR CAST IN STRUCTURE WITH CONDUCTORS. SEE SUMMARY.
- GROUND BOX WITH CONC. APRON
- ELECTRIC SERVICE/POLE #NUMBER
- CONDUIT RUN NUMBER

INTERIM REVIEW  
 DOCUMENT INCOMPLETE. NOT INTENDED FOR PERMIT, BIDDING OR CONSTRUCTION.  
 ENGINEER: TRAVIS E. WILTSHIRE  
 P.E. SERIAL NO: 85219  
 COMPANY NAME: CNG ENGINEERING, PLLC.  
 COMPANY REG. NO. F-7964  
 DATE: 01-20-2023

REV. NO.	DATE	DESCRIPTION	BY

**CNG ENGINEERING**  
 MEP DESIGN | PLANNING | COMMISSIONING  
 1917 N NEW BRAUNFELS AVE, SUITE 201  
 SAN ANTONIO, TEXAS 78208  
 T 210.224.8841 F 210.224.8224  
 www.cngengineering.com  
 TBPE FIRM # F-7964

**PAPE-DAWSON ENGINEERS**  
 SAN ANTONIO | AUSTIN | HOUSTON | FORT WORTH | DALLAS  
 2000 NW LOOP 410 | SAN ANTONIO, TX 78218 | 210.875.9000  
 TEXAS ENGINEERING FIRM #170 | TEXAS SURVEYING FIRM #10028800

CITY OF SAN ANTONIO  
**PUBLIC WORKS DEPARTMENT**

DOLOROSA  
**ELECTRICAL PLANS**

STA 47+81.00 TO STA 51+71.00  
 SHEET 7 OF 8

DESIGN	CHECKED	DRAWN	PROJECT NO.	SUBMITTAL	SHEET NO.
JC	JC	CDC	23-03763	70%	396

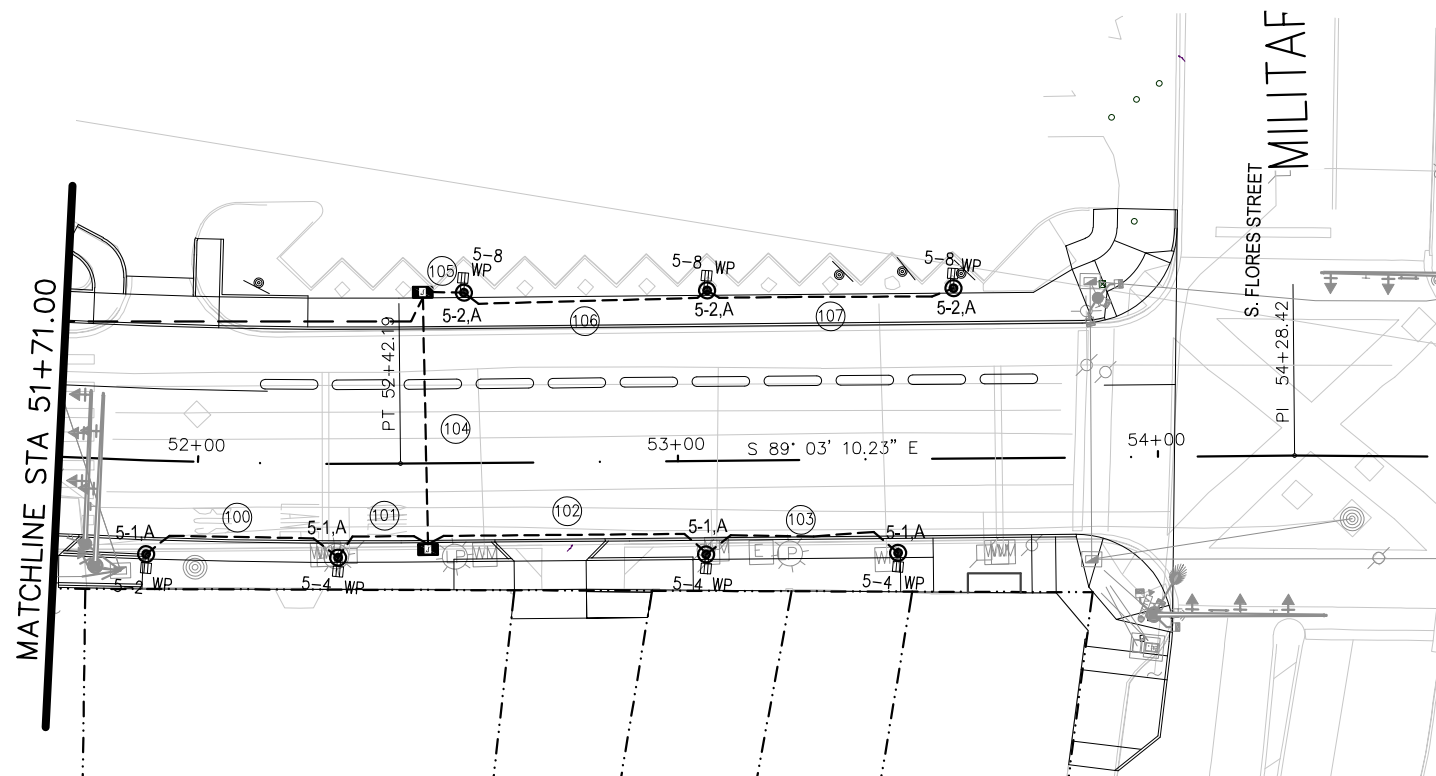

# KEYED NOTES: (THIS SHEET ONLY)

1. NEW LUMINAIRE POLE MOUNTED AT FINISHED GRADE. (TYPICAL).

GENERAL NOTES:

- REFER TO LIGHTING FIXTURE SCHEDULE FOR LUMINAIRE POLE TYPE.
- COORDINATE U.G. CONDUIT INSTALLATION AROUND DRAINAGE STRUCTURE AND OTHER UTILITIES.
- PROVIDE #6 CU. WIRING IN 2" PVC CONDUIT UNDERGROUND CIRCUITS FOR ILLUMINATED BOLLARDS, PEDESTRIAN LIGHTING AND POLE MOUNTED RECEPTACLES.
- SPLICE #10 TO #6 HOME RUN CONDUCTORS AT BASE OF EACH POLE AND RUN CONDUCTORS FROM BASE OF POLE TO POLE MOUNTED RECEPTACLE.

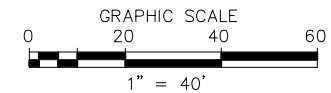
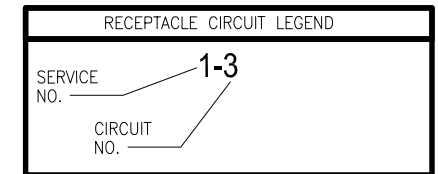
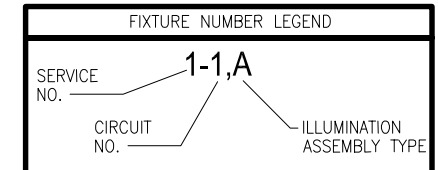

ILLUMINATION LEGEND

- PEDESTRIAN LIGHTING POLE
- GFCI RECEPTACLE WITH WHILE-IN-USE COVER
- EXISTING RACEWAY TO REMAIN
- CONDUIT UNDERGROUND OR CAST IN STRUCTURE WITH CONDUCTORS. SEE SUMMARY.
- GROUND BOX WITH CONC. APRON
- ELECTRIC SERVICE/POLE #NUMBER
- CONDUIT RUN NUMBER
- POWER POLE

CONDUCTOR AND CONDUIT RUN SUMMARY					
RUN NO	GROUND NO. & LENGTH (FEET)	CONDUCTOR NO. & LENGTH (FEET)	CONDUIT (FEET)		REMARKS
			SCH 40	SCH 40	
	#6 BARE	#6 INSULATED	PVC 2"	PVC 1"	
100	54	216		48	
101	32	128		26	
102	72	288		66	
103	53	212		47	
104	65	260	59		
105	22	88		16	
106	6	24		58	
107	64	256		58	
TOTALS	368	1472	59	319	

INTERIM REVIEW  
 DOCUMENT INCOMPLETE. NOT INTENDED FOR PERMIT, BIDDING OR CONSTRUCTION.  
 ENGINEER: TRAVIS E. WILTSHIRE  
 P.E. SERIAL NO: 85219  
 COMPANY NAME: CNG ENGINEERING, PLLC.  
 COMPANY REG. NO. F-7964  
 DATE: 01-20-2023

REV. NO.	DATE	DESCRIPTION	BY

**CNG ENGINEERING**  
 MEP DESIGN | PLANNING | COMMISSIONING  
 1917 N NEW BRAUNFELS AVE, SUITE 201  
 SAN ANTONIO, TEXAS 78208  
 T 210.224.8841 F 210.224.8224  
 www.cngengineering.com  
 TBPE FIRM # F-7964

**PAPE-DAWSON ENGINEERS**  
 SAN ANTONIO | AUSTIN | HOUSTON | FORT WORTH | DALLAS  
 2000 NW LOOP 410 | SAN ANTONIO, TX 78218 | 210.875.9000  
 TEXAS ENGINEERING FIRM #170 | TEXAS SURVEYING FIRM #10028800

CITY OF SAN ANTONIO  
**PUBLIC WORKS DEPARTMENT**

DOLOROSA  
**ELECTRICAL PLANS**  
 STA 51+71.00 TO STA 54+29.00  
 SHEET 8 OF 8

DESIGN	CHECKED	DRAWN	PROJECT NO.	SUBMITTAL	SHEET NO.
JC	JC	CDC	23-03763	70%	397

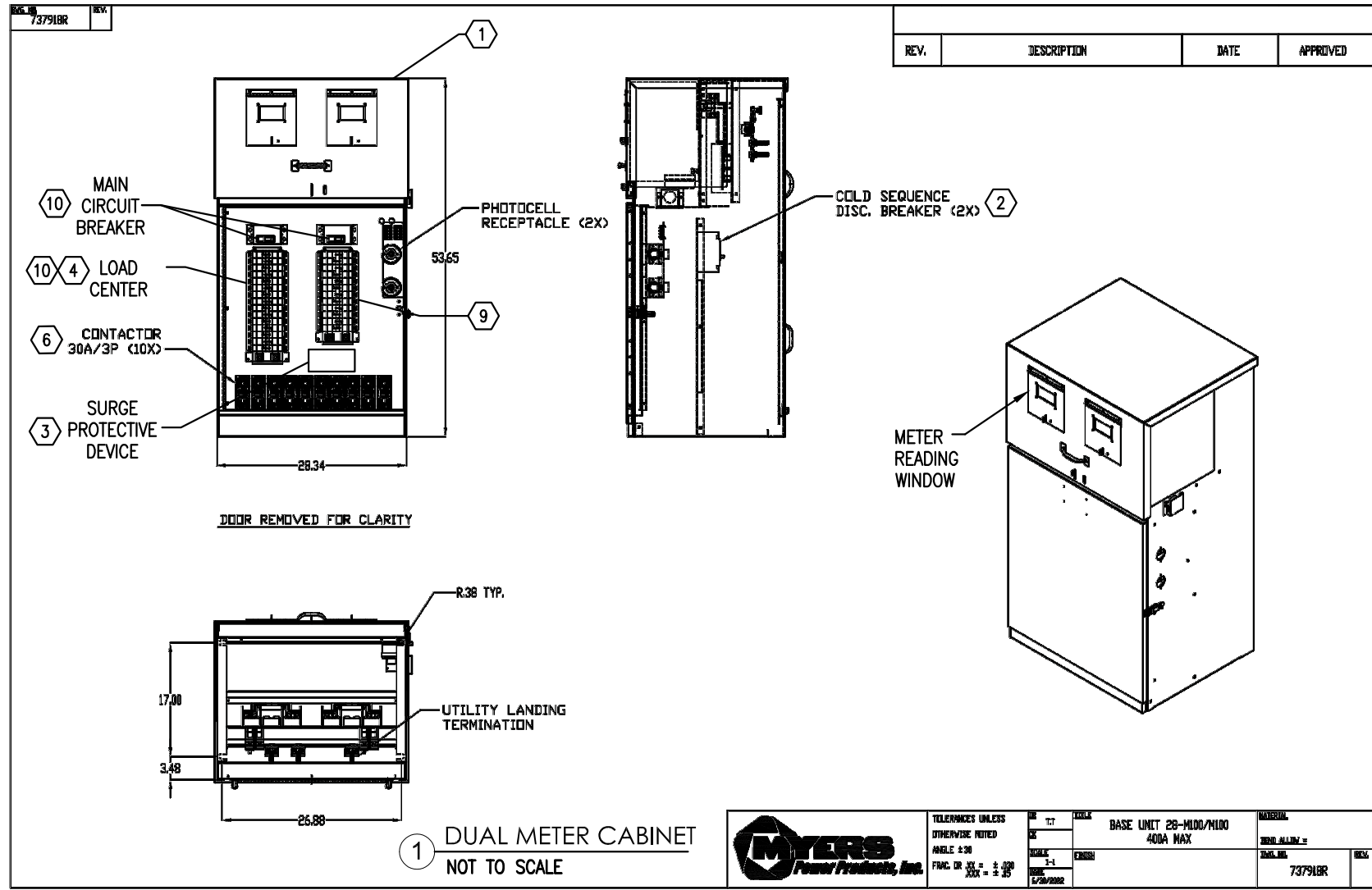

**GENERAL NOTES:**

- A. EACH SERVICE LOCATION SHOWN ON THE PLANS DENOTED BY 'ES#' WILL HAVE A DOUBLE SECTION SERVICE PEDESTAL. (1) FOR PEDESTRIAN ILLUMINATION/RECEPTACLE POWER AND (1) FOR TRAFFIC CONTROLS.
- # KEYED NOTES: (DETAILS NO. 1 AND NO. 2 ONLY)
  1. PROVIDE MYERS 28-M100/M100, 400A RATED, OR APPROVED EQUAL. CONTRACTOR TO SUBMIT DIMENSIONED SHOP DRAWINGS FOR REVIEW BY ENGINEERING AND CPS ELECTRIC,
  2. GRID-TIED DISCONNECT TO BE FURNISHED AND INSTALLED BY DUAL METER MANUFACTURER. CONTRACTOR TO FURNISH AND INSTALL LOAD SIDE CONDUCTORS TO METER SAFETY SOCKET. CPS ENERGY TO MAKE ALL CONNECTIONS TO GRID-TIED DISCONNECT.
  3. PROVIDE SPD AS INDICATED. BASIS OF DESIGN PRODUCT IS LEA INTERNATIONAL, TRANSECTOR SPD SP PLUS 200, 120/208-SINGLE PHASE OR APPROVED EQUAL. ANY PROPOSED SUBSTITUTION MUST BE REQUESTED WITH FULL SUBMITTAL DATA FOR CONSIDERATION BY ENGINEER OF RECORD. CONNECT TO PANEL USING #2 WIRING.
  4. REFER TO PANEL BOARD SCHEDULES FOR CIRCUIT QUANTITY AND PANEL CONFIGURATION. NUMBER OF SPACES/CIRCUITS VARIES FOR EACH SERVICE.
  5. COORDINATE WITH CPS ENERGY THE EXTENSION OF 208V, SINGLE PHASE SERVICE LINE FROM THE NEAREST DOWNTOWN UNDERGROUND DISTRIBUTION MANHOLE. CONTRACTOR TO INSTALL UNDERGROUND CONDUIT FROM MANHOLE TO ELECTRICAL SERVICE PEDESTAL AND CONDUIT SLEEVES IN CONCRETE PAD. SERVICE LATERAL CONDUCTORS ARE TO BE FURNISHED AND INSTALLED BY CPS ENERGY.
  6. REFER TO PANELBOARD SCHEDULE AND PLANS FOR QUANTITY OF CONTACTORS REQUIRED PER SERVICE.
  7. REFER TO ELECTRICAL GROUNDING DIAGRAM.
  8. CONDUCTORS PROVIDED AND INSTALLED BY CONTRACTOR
  9. SECOND SECTION OF ENCLOSURE RESERVED FOR TRAFFIC SIGNAL SERVICE AND EQUIPMENT. REFER TO TRAFFIC SIGNAL DRAWINGS FOR ADDITIONAL INFORMATION AND CONCRETE SLEEVE REQUIREMENTS.
  10. COORDINATE WITH CPS ENERGY THE AVAILABLE FAULT CURRENT RATING. ADJUST AIC RATINGS AS REQUIRED TO ACCOMMODATE AVAILABLE FAULT CURRENT.
  11. BOND NEUTRAL TO GROUND AT THIS LOCATION (GROUND ORIGINATION). REFER TO TYPICAL DUAL METER ONE LINE DIAGRAM.

INTERIM REVIEW  
DOCUMENT INCOMPLETE. NOT INTENDED FOR PERMIT, BIDDING OR CONSTRUCTION.  
ENGINEER: TRAVIS E. WILTSHIRE  
P.E. SERIAL NO: 85219  
COMPANY NAME: CNG ENGINEERING, PLLC.  
COMPANY REG. NO. F-7964  
DATE: 01-20-2023

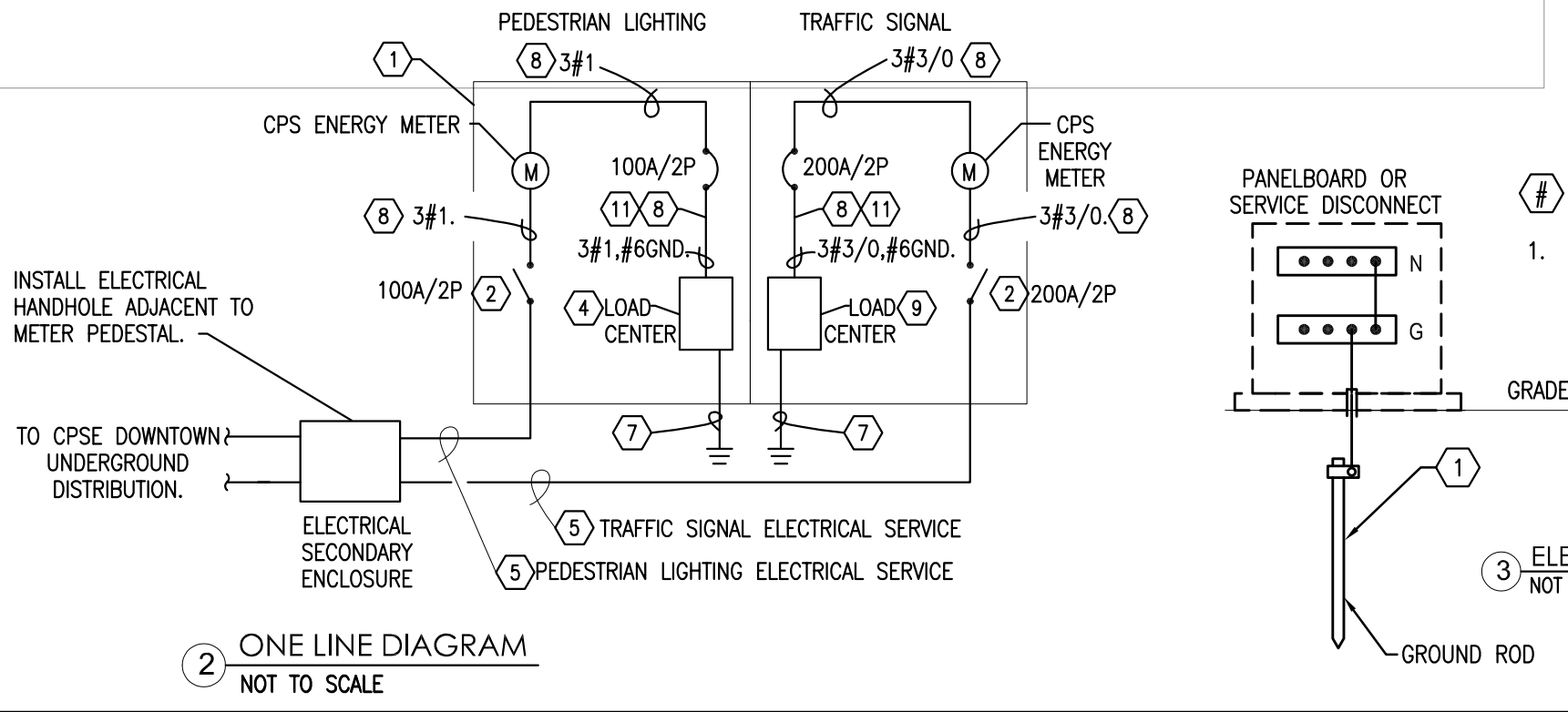

# KEYED NOTES: (DETAIL NO. 3 ONLY)

1. #8 COPPER GROUNDING ELECTRODE CONDUCTOR IN PVC TO EXOTHERMIC CONNECTION AT 3/4" x 10' COPPER CLAD STEEL GROUND ROD.

REV. NO.	DATE	DESCRIPTION	BY

**CNG ENGINEERING**  
MEP DESIGN | PLANNING | COMMISSIONING  
1917 N NEW BRAUNFELS AVE, SUITE 201  
SAN ANTONIO, TEXAS 78208  
T 210.224.8841 F 210.224.8224  
www.cngengineering.com  
TBPE FIRM # F-7964

**PAPE-DAWSON ENGINEERS**  
SAN ANTONIO | AUSTIN | HOUSTON | FORT WORTH | DALLAS  
2000 NW LOOP 410 | SAN ANTONIO, TX 78218 | 210.375.9000  
TEXAS ENGINEERING FIRM #170 | TEXAS SURVEYING FIRM #10028800

CITY OF SAN ANTONIO  
**PUBLIC WORKS DEPARTMENT**

DOLOROSA  
ELECTRICAL SERVICE  
ONE-LINE DIAGRAM  
DUAL METER

DESIGN	CHECKED	DRAWN	PROJECT NO.	SUBMITTAL	SHEET NO.
JC	JC	CDC	23-03763	70%	398

REFER TO TRAFFIC SIGNAL DRAWINGS FOR CONDUCTOR AND SERVICE SIZE

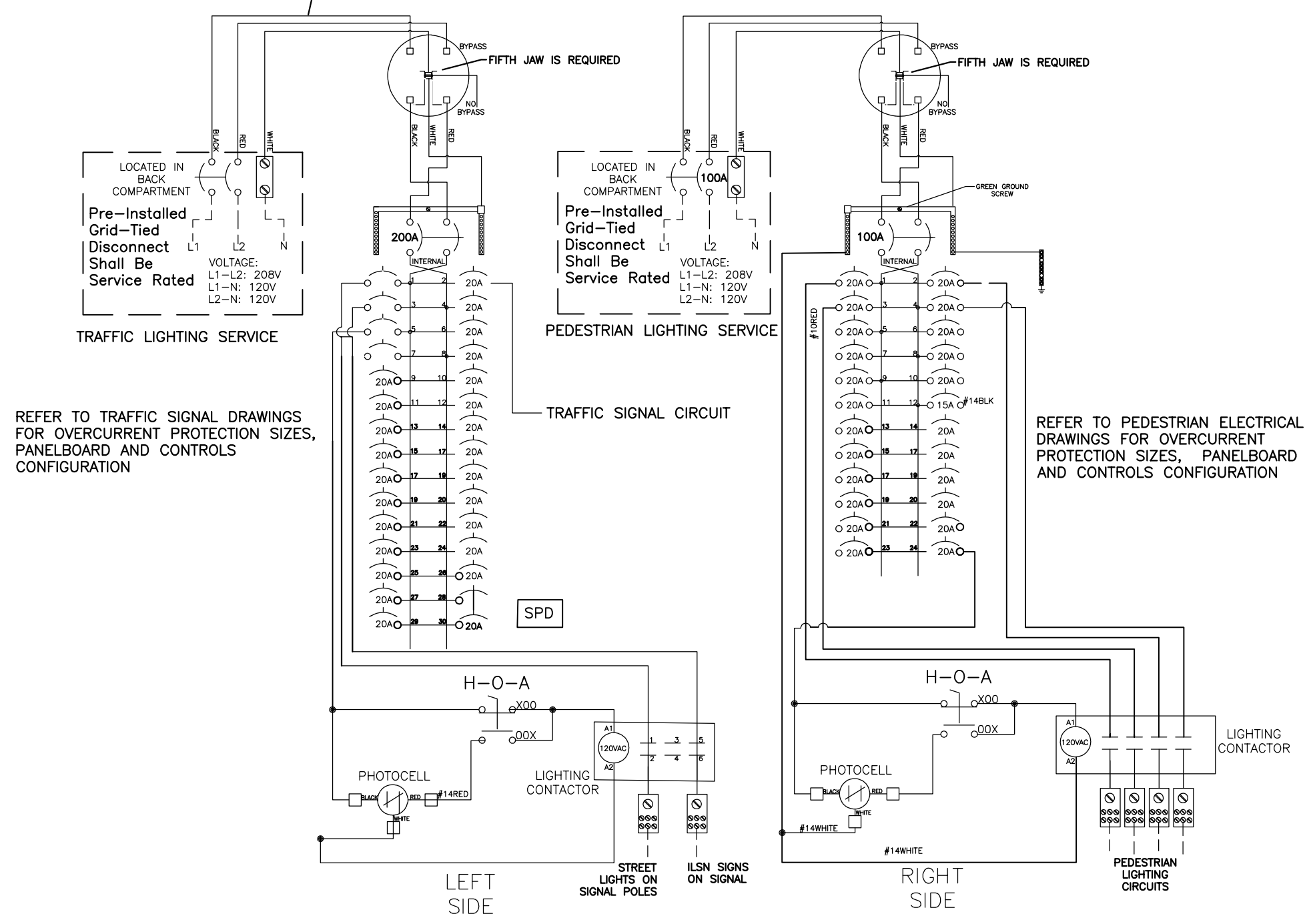

REFER TO TRAFFIC SIGNAL DRAWINGS FOR OVERCURRENT PROTECTION SIZES, PANELBOARD AND CONTROLS CONFIGURATION

REFER TO PEDESTRIAN ELECTRICAL DRAWINGS FOR OVERCURRENT PROTECTION SIZES, PANELBOARD AND CONTROLS CONFIGURATION

1 TYPICAL DUAL METER ONE LINE DIAGRAM  
NOT TO SCALE

INTERIM REVIEW  
DOCUMENT INCOMPLETE. NOT INTENDED FOR PERMIT, BIDDING OR CONSTRUCTION.  
ENGINEER: TRAVIS E. WILTSHIRE  
P.E. SERIAL NO: 85219  
COMPANY NAME: CNG ENGINEERING, PLLC.  
COMPANY REG. NO. F-7964  
DATE: 01-20-2023

REV. NO.	DATE	DESCRIPTION	BY

**CNG ENGINEERING**  
MEP DESIGN | PLANNING | COMMISSIONING  
1917 N NEW BRAUNFELS AVE, SUITE 201  
SAN ANTONIO, TEXAS 78208  
T 210.224.8841 F 210.224.8224  
www.cngengineering.com  
TBPE FIRM # F-7964

**PAPE-DAWSON ENGINEERS**  
SAN ANTONIO | AUSTIN | HOUSTON | FORT WORTH | DALLAS  
2000 NW LOOP 410 | SAN ANTONIO, TX 78218 | 210.375.9000  
TEXAS ENGINEERING FIRM #170 | TEXAS SURVEYING FIRM #10028800

CITY OF SAN ANTONIO  
**PUBLIC WORKS DEPARTMENT**

DOLOROSA  
ELECTRICAL DUAL METER ONE-LINE DIAGRAM

DESIGN	CHECKED	DRAWN	PROJECT NO.	SUBMITTAL	SHEET NO.
JC	JC	CDC	23-03763	70%	399

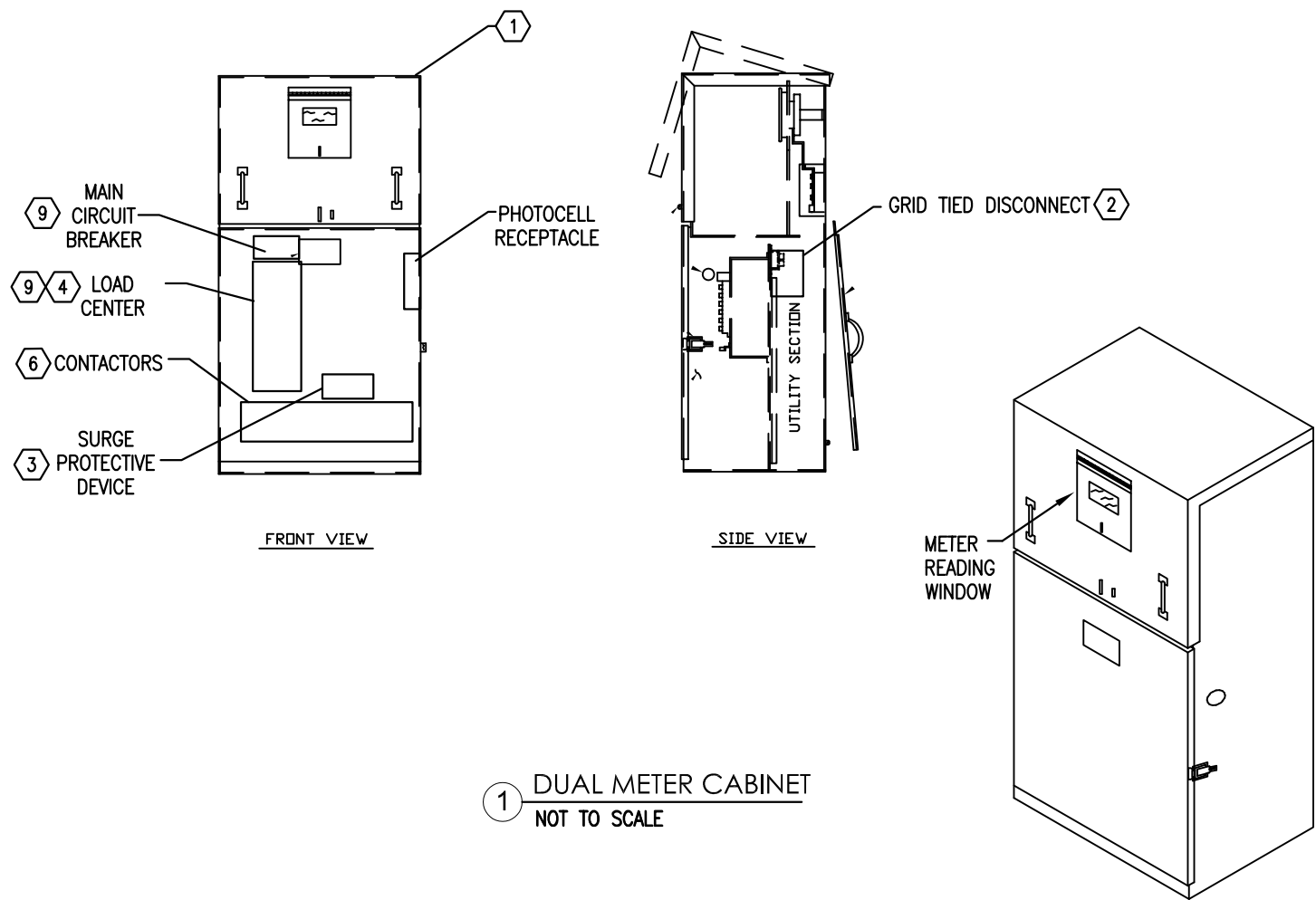

1 DUAL METER CABINET  
NOT TO SCALE

**GENERAL NOTES:**

- A. EACH SERVICE LOCATION SHOWN ON THE PLANS DENOTED BY 'ES#' WILL HAVE A DOUBLE SECTION SERVICE PEDESTAL. (1) FOR PEDESTRIAN ILLUMINATION/RECEPTACLE POWER AND (1) FOR TRAFFIC CONTROLS.
- # KEYED NOTES: (DETAILS NO. 1 AND NO. 2 ONLY)
  - 1. PROVIDE MYERS 28-SINGLE METER CABINET, 400A RATED, OR APPROVED EQUAL. CONTRACTOR TO SUBMIT DIMENSIONED SHOP DRAWINGS FOR REVIEW BY ENGINEERING AND CPS ELECTRIC,
  - 2. GRID-TIED DISCONNECT TO BE FURNISHED AND INSTALLED BY DUAL METER MANUFACTURER. CONTRACTOR TO FURNISH AND INSTALL LOAD SIDE CONDUCTORS TO METER SAFETY SOCKET. CPS ENERGY TO MAKE ALL CONNECTIONS TO GRID-TIED DISCONNECT.
  - 3. PROVIDE SPD AS INDICATED. BASIS OF DESIGN PRODUCT IS LEA INTERNATIONAL, TRANSECTOR SPD SP PLUS 200, 120/208-SINGLE PHASE OR APPROVED EQUAL. ANY PROPOSED SUBSTITUTION MUST BE REQUESTED WITH FULL SUBMITTAL DATA FOR CONSIDERATION BY ENGINEER OF RECORD. CONNECT TO PANEL USING #2 WIRING.
  - 4. REFER TO PANEL BOARD SCHEDULES FOR CIRCUIT QUANTITY AND PANEL CONFIGURATION. NUMBER OF SPACES/CIRCUITS VARIES FOR EACH SERVICE.
  - 5. COORDINATE WITH CPS ENERGY THE EXTENSION OF 208V, SINGLE PHASE SERVICE LINE FROM THE NEAREST DOWNTOWN UNDERGROUND DISTRIBUTION MANHOLE. CONTRACTOR TO INSTALL UNDERGROUND CONDUIT FROM MANHOLE TO ELECTRICAL SERVICE PEDESTAL AND CONDUIT SLEEVES IN CONCRETE PAD. SERVICE LATERAL CONDUCTORS ARE TO BE FURNISHED AND INSTALLED BY CPS ENERGY.
  - 6. REFER TO PANELBOARD SCHEDULE AND PLANS FOR QUANTITY OF CONTACTORS REQUIRED PER SERVICE.
  - 7. REFER TO ELECTRICAL GROUNDING DIAGRAM.
  - 8. CONDUCTORS PROVIDED AND INSTALLED BY CONTRACTOR
  - 9. COORDINATE WITH CPS ENERGY THE AVAILABLE FAULT CURRENT RATING. ADJUST AIC RATINGS AS REQUIRED TO ACCOMMODATE AVAILABLE FAULT CURRENT.
  - 10. BOND NEUTRAL TO GROUND AT THIS LOCATION (GROUND ORIGINATION). REFER TO TYPICAL DUAL METER ONE LINE DIAGRAM.

INTERIM REVIEW

DOCUMENT INCOMPLETE. NOT INTENDED FOR PERMIT, BIDDING OR CONSTRUCTION.

ENGINEER: TRAVIS E. WILTSHIRE

P.E. SERIAL NO: 85219

COMPANY NAME: CNG ENGINEERING, PLLC.

COMPANY REG. NO. F-7964

DATE: 01-20-2023

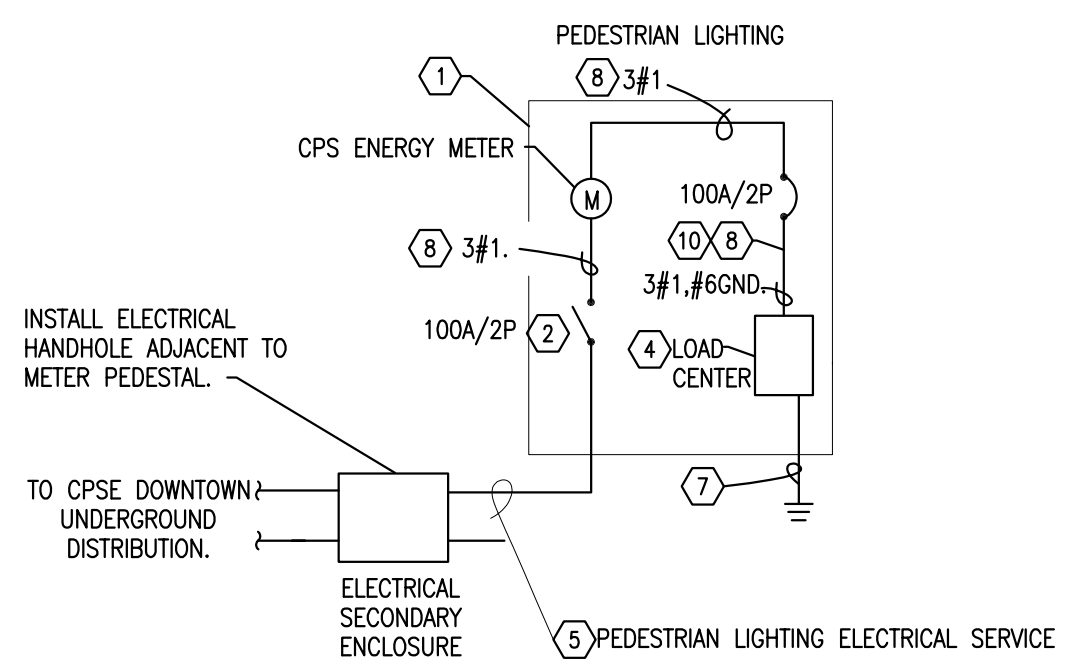

2 ONE LINE DIAGRAM  
NOT TO SCALE

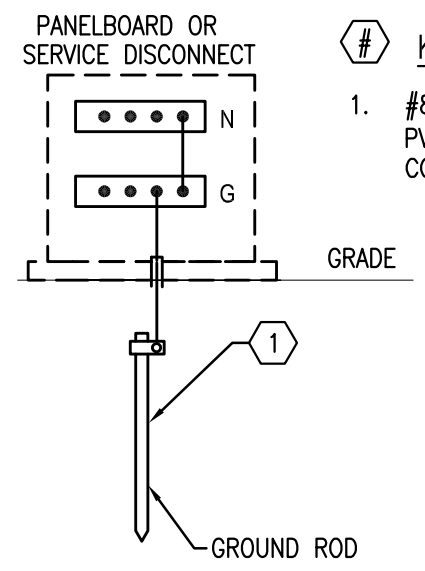

3 ELECTRICAL GROUNDING DIAGRAM  
NOT TO SCALE

- # KEYED NOTES: (DETAIL NO. 3 ONLY)
  - 1. #8 COPPER GROUNDING ELECTRODE CONDUCTOR IN PVC TO EXOTHERMIC CONNECTION AT 3/4" x 10' COPPER CLAD STEEL GROUND ROD.

REV. NO.	DATE	DESCRIPTION	BY

**CNG ENGINEERING**  
MEP DESIGN | PLANNING | COMMISSIONING  
1917 N NEW BRAUNFELS AVE, SUITE 201  
SAN ANTONIO, TEXAS 78208  
T 210.224.8841 F 210.224.8224  
www.cngengineering.com  
TBPE FIRM # F-7964

**PAPE-DAWSON ENGINEERS**  
SAN ANTONIO | AUSTIN | HOUSTON | FORT WORTH | DALLAS  
2000 NW LOOP 410 | SAN ANTONIO, TX 78218 | 210.375.9000  
TEXAS ENGINEERING FIRM #170 | TEXAS SURVEYING FIRM #10028800

CITY OF SAN ANTONIO  
**PUBLIC WORKS DEPARTMENT**

DOLOROSA

**ELECTRICAL SERVICE  
ONE-LINE DIAGRAM  
SINGLE METER**

DESIGN	CHECKED	DRAWN	PROJECT NO.	SUBMITTAL	SHEET NO.
JC	JC	CDC	23-03763	70%	400

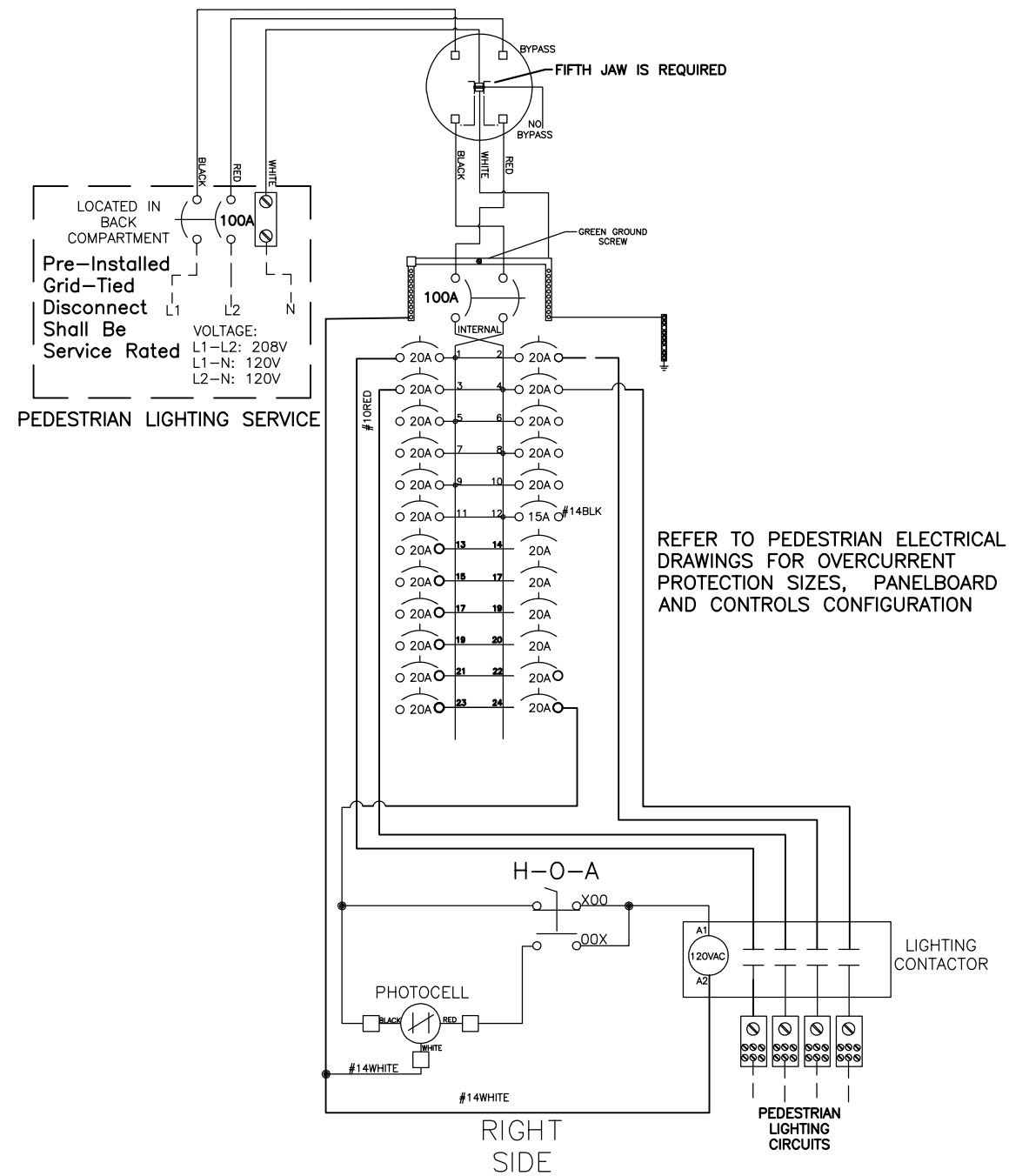

1 TYPICAL SINGLE METER ONE LINE DIAGRAM  
NOT TO SCALE

INTERIM REVIEW

DOCUMENT INCOMPLETE. NOT INTENDED FOR PERMIT, BIDDING OR CONSTRUCTION.

ENGINEER: TRAVIS E. WILTSHIRE

P.E. SERIAL NO: 85219

COMPANY NAME: CNG ENGINEERING, PLLC.

COMPANY REG. NO. F-7964

DATE: 01-20-2023

REV. NO.	DATE	DESCRIPTION	BY

**CNG ENGINEERING**  
MEP DESIGN | PLANNING | COMMISSIONING

1917 N NEW BRAUNFELS AVE, SUITE 201  
SAN ANTONIO, TEXAS 78208  
T 210.224.8841 F 210.224.8224  
www.cngengineering.com  
TBPE FIRM # F-7964

**PAPE-DAWSON ENGINEERS**

SAN ANTONIO | AUSTIN | HOUSTON | FORT WORTH | DALLAS  
2000 NW LOOP 410 | SAN ANTONIO, TX 78218 | 210.375.9000  
TEXAS ENGINEERING FIRM #470 | TEXAS SURVEYING FIRM #10028800

CITY OF SAN ANTONIO  
**PUBLIC WORKS DEPARTMENT**

DOLOROSA  
ELECTRICAL SINGLE METER ONE-LINE DIAGRAM

DESIGN	CHECKED	DRAWN	PROJECT NO.	SUBMITTAL	SHEET NO.
JC	JC	CDC	23-03763	70%	401

### PANELBOARD 'ES #1'

PROJECT :	Dolorosa	MAIN CIRCUIT BREAKER :	100A	ENCLOSURE :	NEMA 3R	0	RCPT	5	HEAT
PROJECT # :		MAIN LUGS ONLY :		MOUNTING :	SURFACE	1	INT LTG	6	A/C
LOCATION :	CABINET ENCLOSURE	BUSSING :	100A	OCPTYPES :	BOLT-ON	2	EXT LTG	7	KITCH
NOTES :	Electrical Service No. 1	VOLTAGE :	120/208V, 1-PH, 3-W	PROVIDE :	NEUTRAL BUS	3	EQPT	8	ELEV
		INTERRUPTING :	10 kAIC RMS SYM		GROUND BUS	4	FANS	9	EWH

CKT	AMPS	POLE	CIRCUIT DESCRIPTION	LOAD	TYPE	PH	TYPE	LOAD	CIRCUIT DESCRIPTION	AMPS	POLE	CKT
1	20	2	PEDESTRIAN LIGHTING CIRCUIT NO. 1	369	2	A	0	540	RECEPTACLES	20	1	2
3				369	2	B	0	720	RECEPTACLES	20	1	4
5	20	2	PEDESTRIAN LIGHTING CIRCUIT NO. 2	402	2	A	0	540	RECEPTACLES	20	1	6
7				402	2	B	0	540	RECEPTACLES	20	1	8
9	20	1	LTG CONTACTOR	180	3	A	0	720	RECEPTACLES	20	1	10
11	20	1	SPARE			B	0	360	RECEPTACLES	20	1	12
13	20	1	SPARE			A	0	720	RECEPTACLES	20	1	14
15	20	1	SPARE			B			SPARE	20	1	16
17	20	1	SPARE			A			SPARE	20	1	18
19	20	1	SPARE			B			SPARE	20	1	20
21	20	1	SPARE			A			SPARE	20	1	22
23	20	1	SPARE			B			SPARE	20	1	24
25	20	1	SPARE			A			SPARE	20	1	26
27	20	1	SPARE			B			SPARE	20	1	28
29	20	1	IRRIGATION CONTROLLER	240	3	A			SURGE PROTECTION DEVICE	60	2	30

	PANEL VA	SUB FEED	FEED THRU	TOTAL CONN	TOTAL DEMAND VA	TOTAL DEMAND AMPS	NOTES :
PHASE A	3,711	0	0	3,711	3,945	33	
PHASE B	2,391	0	0	2,391	2,541	21	
TOTAL	6,101	0	0	6,101	6,486	27	REVISIONS: CNG ENGINEERING, PLLC. R3.1 - Nov. 4

### PANELBOARD 'ES #2'

PROJECT :	Dolorosa	MAIN CIRCUIT BREAKER :	100A	ENCLOSURE :	NEMA 3R	0	RCPT	5	HEAT
PROJECT # :		MAIN LUGS ONLY :		MOUNTING :	SURFACE	1	INT LTG	6	A/C
LOCATION :	CABINET ENCLOSURE	BUSSING :	100A	OCPTYPES :	BOLT-ON	2	EXT LTG	7	KITCH
NOTES :	Upgraded/Relocated Electrical Service	VOLTAGE :	120/208V, 1-PH, 3-W	PROVIDE :	NEUTRAL BUS	3	EQPT	8	ELEV
	Electrical Service No. 2	INTERRUPTING :	10 kAIC RMS SYM		GROUND BUS	4	FANS	9	EWH

CKT	AMPS	POLE	CIRCUIT DESCRIPTION	LOAD	TYPE	PH	TYPE	LOAD	CIRCUIT DESCRIPTION	AMPS	POLE	CKT
1	20	2	PEDESTRIAN LIGHTING CIRCUIT NO. 1	235	2	A	0	540	RECEPTACLES	20	1	2
3				235	2	B	0	720	RECEPTACLES	20	1	4
5	20	2	PEDESTRIAN LIGHTING CIRCUIT NO. 2	268	2	A	0	720	RECEPTACLES	20	1	6
7				268	2	B	0	540	RECEPTACLES	20	1	8
9	20	1	LTG CONTACTOR	180	3	A			SPARE	20	1	10
11	20	1	SPARE			B			SPARE	20	1	12
13	20	1	SPARE			A			SPARE	20	1	14
15	20	1	SPARE			B			SPARE	20	1	16
17	20	1	SPARE			A			SPARE	20	1	18
19	20	1	SPARE			B			SPARE	20	1	20
21	20	1	SPARE			A			SPARE	20	1	22
23	20	1	SPARE			B			SPARE	20	1	24
25	20	1	SPARE			A			SPARE	20	1	26
27	20	1	SPARE			B			SPARE	20	1	28
29	20	1	SPARE			A			SURGE PROTECTION DEVICE	60	2	30

	PANEL VA	SUB FEED	FEED THRU	TOTAL CONN	TOTAL DEMAND VA	TOTAL DEMAND AMPS	NOTES :
PHASE A	1,943	0	0	1,943	2,074	17	
PHASE B	1,763	0	0	1,763	1,882	16	
TOTAL	3,705	0	0	3,705	3,956	16	REVISIONS: CNG ENGINEERING, PLLC. R3.1 - Nov. 4

### EXISTING PANELBOARD 'ES #3' - 936 DOLOROSA ST - PEDESTRIAN LIGHTING

PROJECT :	Dolorosa	MAIN CIRCUIT BREAKER :	100A	ENCLOSURE :	NEMA 3R	0	RCPT	5	HEAT
PROJECT # :		MAIN LUGS ONLY :		MOUNTING :	SURFACE	1	INT LTG	6	A/C
LOCATION :	CABINET ENCLOSURE	BUSSING :	100A	OCPTYPES :	BOLT-ON	2	EXT LTG	7	KITCH
NOTES :	Existing Service (Dolorosa St)	VOLTAGE :	120/208V, 1-PH, 3-W	PROVIDE :	NEUTRAL BUS	3	EQPT	8	ELEV
	Electrical Service No. 3	INTERRUPTING :	10 kAIC RMS SYM		GROUND BUS	4	FANS	9	EWH

CKT	AMPS	POLE	CIRCUIT DESCRIPTION	LOAD	TYPE	PH	TYPE	LOAD	CIRCUIT DESCRIPTION	AMPS	POLE	CKT
1	20	2	EXISTING STREET LIGHTING	532	2	A	0	360	EXISTING RECEPTACLES	20	1	2
3				532	2	B	0	360	EXISTING RECEPTACLES	20	1	4
5	20	2	EXISTING STREET LIGHTING	509	2	A	0	360	EXISTING RECEPTACLES	20	1	6
7				509	2	B	0	360	EXISTING RECEPTACLES	20	1	8
9	20	2	EXISTING STREET LIGHTING	272	2	A	0	360	EXISTING RECEPTACLES	20	1	10
11				272	2	B	0	360	EXISTING RECEPTACLES	20	1	12
13	20	1	EXISTING RECEPTACLES	360	0	A	4	180	EXISTING LTG CONTACTOR	20	1	14
15	20	1	EXISTING RECEPTACLES	360	0	B	0	540	RECEPTACLES	20	1	16
17	20	1	EXISTING RECEPTACLES	180	0	A	0	360	RECEPTACLES	20	1	18
19	20	1	EXISTING RECEPTACLES	360	0	B	0	540	RECEPTACLES	20	1	20
21	20	1	EXISTING RECEPTACLES	360	0	A	0	540	RECEPTACLES	20	1	22
23	20	1	EXISTING RECEPTACLES	360	0	B	0	360	RECEPTACLES	20	1	24
25	20	2	PEDESTRIAN LIGHTING CIRCUIT NO. 3	235	2	A	0	360	RECEPTACLES	20	1	26
27				235	2	B						
29	20	2	PEDESTRIAN LIGHTING CIRCUIT NO. 4	369	2	A			EXISTING SURGE PROTECTION DEVICE	60	2	30
31				369	2	B	0	540	RECEPTACLES	20	1	32
33	20	1	IRRIGATION CONTROLLER	240	3	A	0		BUSSED SPACE	20	1	34
35	20	1	BUSSED SPACE			B	0		BUSSED SPACE	20	1	36
37	20	1	BUSSED SPACE			A	0		BUSSED SPACE	20	1	38
39	20	1	BUSSED SPACE			B	0		BUSSED SPACE	20	1	40
41	20	1	BUSSED SPACE			A	0		BUSSED SPACE	20	1	42

  

	PANEL VA	SUB FEED	FEED THRU	TOTAL CONN	TOTAL DEMAND VA	TOTAL DEMAND AMPS	NOTES :
PHASE A	5,575	0	0	5,575	6,056	50	
PHASE B	6,055	0	0	6,055	6,577	55	
TOTAL	11,630	0	0	11,630	12,633	53	REVISIONS: CNG ENGINEERING, PLLC. R3.1 - Nov. 4

#### INTERIM REVIEW

DOCUMENT INCOMPLETE. NOT INTENDED FOR PERMIT, BIDDING OR CONSTRUCTION.  
 ENGINEER: TRAVIS E. WILTSHIRE  
 P.E. SERIAL NO: 85219  
 COMPANY NAME: CNG ENGINEERING, PLLC.  
 COMPANY REG. NO. F-7964  
 DATE: 01-20-2023

REV. NO.	DATE	DESCRIPTION	BY



**CNG ENGINEERING**  
 MEP DESIGN | PLANNING | COMMISSIONING  
 1917 N NEW BRAUNFELS AVE, SUITE 201  
 SAN ANTONIO, TEXAS 78208  
 T 210.224.8841 F 210.224.8224  
 www.cngengineering.com  
 TBPE FIRM # F-7964

### PAPE-DAWSON ENGINEERS

SAN ANTONIO | AUSTIN | HOUSTON | FORT WORTH | DALLAS  
 2000 NW LOOP 410 | SAN ANTONIO, TX 78218 | 210.375.9000  
 TEXAS ENGINEERING FIRM #170 | TEXAS SURVEYING FIRM #10028800



### DOLOROSA ELECTRICAL PANEL SCHEDULES

SHEET 1 OF 2

DESIGN	CHECKED	DRAWN	PROJECT NO.	SUBMITTAL	SHEET NO.
JC	JC	CDC	23-03763	70%	402



EXISTING PANELBOARD 'ES #4' - 720 DOLOROSA ST - PEDESTRIAN LIGHTING															
PROJECT :	Dolorosa	MAIN CIRCUIT BREAKER :	100A	ENCLOSURE :	NEMA 3R	0	RCPT	5	HEAT						
PROJECT # :		MAIN LUGS ONLY :		MOUNTING :	SURFACE	1	INT LTG	6	A/C						
LOCATION :	CABINET ENCLOSURE	BUSSING :	100A	OC P TYPES :	BOLT-ON	2	EXT LTG	7	KITCH						
NOTES :	Existing Service (Dolorosa St)	VOLTAGE :	120/208V, 1-PH, 3-W	PROVIDE :	NEUTRAL BUS	3	EQPT	8	ELEV						
	Electrical Service No. 4	INTERRUPTING :	10 kAIC RMS SYM		GROUND BUS	4	FANS	9	EWH						
CKT	AMPS	POLE	CIRCUIT DESCRIPTION				LOAD	TYPE	PH	TYPE	LOAD	CIRCUIT DESCRIPTION	AMPS	POLE	CKT
1	20	2	EXISTING STREET LIGHTING				314	2	A	0	720	EXISTING RECEPTACLES	20	1	2
3							314	2	B	0	540	EXISTING RECEPTACLES	20	1	4
5	20	1	EXISTING RECEPTACLES				360	0	A	0	720	EXISTING RECEPTACLES	20	1	6
7	20	1	EXISTING RECEPTACLES				360	0	B			EXISTING SURGE PROTECTION DEVICE	60	3	8
9	20	1	EXISTING RECEPTACLES				720	0	A						10
11	20	1	EXISTING LTG CONTACTOR				180	3	B						12
13	20	1	EXISTING LTG CONTACTOR				180	3	A	0	540	RECEPTACLES	20	1	14
15	20	2	PEDESTRIAN LIGHTING CIRCUIT NO. 2				335	2	B	0	720	RECEPTACLES	20	1	16
17							335	2	A	0	540	RECEPTACLES	20	1	18
19	20	2	PEDESTRIAN LIGHTING CIRCUIT NO. 3				302	2	B	0	540	RECEPTACLES	20	1	20
21							302	2	A	0	360	RECEPTACLES	20	1	22
23	20	1	SPARE						B	0	360	SPARE	20	1	24
25	20	1	SPARE						A	0	540	SPARE	20	1	26
27	20	1	SPARE						B	0	360	SPARE	20	1	28
29	20	1	IRRIGATION CONTROLLER				240		A	0	540	SPARE	20	1	30
			PANEL VA	SUB FEED	FEED THRU	TOTAL CONN	TOTAL DEMAND		NOTES :						
			VA			VA	AMPS								
PHASE A			6,411	0	0	6,411	6,710	56							
PHASE B			4,011	0	0	4,011	4,198	35							
TOTAL			10,421	0	0	10,421	10,907	45	REVISIONS: CNG ENGINEERING, PLLC. R3.1 - Nov. 4						

PANELBOARD 'ES #5'															
PROJECT :	Dolorosa	MAIN CIRCUIT BREAKER :	100A	ENCLOSURE :	NEMA 3R	0	RCPT	5	HEAT						
PROJECT # :		MAIN LUGS ONLY :		MOUNTING :	SURFACE	1	INT LTG	6	A/C						
LOCATION :	CABINET ENCLOSURE	BUSSING :	100A	OC P TYPES :	BOLT-ON	2	EXT LTG	7	KITCH						
NOTES :	Electrical Service No. 5	VOLTAGE :	120/208V, 1-PH, 3-W	PROVIDE :	NEUTRAL BUS	3	EQPT	8	ELEV						
		INTERRUPTING :	10 kAIC RMS SYM		GROUND BUS	4	FANS	9	EWH						
CKT	AMPS	POLE	CIRCUIT DESCRIPTION				LOAD	TYPE	PH	TYPE	LOAD	CIRCUIT DESCRIPTION	AMPS	POLE	CKT
1	20	2	PEDESTRIAN LIGHTING CIRCUIT NO. 1				268	2	A	0	720	RECEPTACLES	20	1	2
3							268	2	B	0	720	RECEPTACLES	20	1	4
5	20	2	PEDESTRIAN LIGHTING CIRCUIT NO. 2				284	2	A	0	360	RECEPTACLES	20	1	6
7							284	2	B	0	540	RECEPTACLES	20	1	8
9	20	1	LTG CONTACTOR				180	3	A			SPARE	20	1	10
11	20	1	SPARE							B		SPARE	20	1	12
13	20	1	SPARE						A			SPARE	20	1	14
15	20	1	SPARE							B		SPARE	20	1	16
17	20	1	SPARE						A			SPARE	20	1	18
19	20	1	SPARE							B		SPARE	20	1	20
21	20	1	SPARE						A			SPARE	20	1	22
23	20	1	SPARE							B		SPARE	20	1	24
25	20	1	SPARE						A			SPARE	20	1	26
27	20	1	SPARE							B		SPARE	20	1	28
29	20	1	IRRIGATION CONTROLLER				240	3	A			SURGE PROTECTION DEVICE	60	2	30
			PANEL VA	SUB FEED	FEED THRU	TOTAL CONN	TOTAL DEMAND		NOTES :						
			VA			VA	AMPS								
PHASE A			2,052	0	0	2,052	2,198	18							
PHASE B			1,812	0	0	1,812	1,941	16							
TOTAL			3,863	0	0	3,863	4,139	17	REVISIONS: CNG ENGINEERING, PLLC. R3.1 - Nov. 4						

INTERIM REVIEW

DOCUMENT INCOMPLETE. NOT INTENDED FOR PERMIT, BIDDING OR CONSTRUCTION.

ENGINEER: TRAVIS E. WILTSHIRE

P.E. SERIAL NO: 85219

COMPANY NAME: CNG ENGINEERING, PLLC.

COMPANY REG. NO. F-7964

DATE: 01-20-2023

REV. NO.	DATE	DESCRIPTION	BY

**CNG ENGINEERING**  
MEP DESIGN | PLANNING | COMMISSIONING

1917 N NEW BRAUNFELS AVE, SUITE 201  
SAN ANTONIO, TEXAS 78208  
T 210.224.8841 F 210.224.8224  
www.cngengineering.com  
TBPE FIRM # F-7964

**PAPE-DAWSON ENGINEERS**

SAN ANTONIO | AUSTIN | HOUSTON | FORT WORTH | DALLAS  
2000 NW LOOP 410 | SAN ANTONIO, TX 78218 | 210.375.9000  
TEXAS ENGINEERING FIRM #170 | TEXAS SURVEYING FIRM #10028800

CITY OF SAN ANTONIO  
**PUBLIC WORKS DEPARTMENT**

DOLOROSA  
ELECTRICAL PANEL  
SCHEDULES

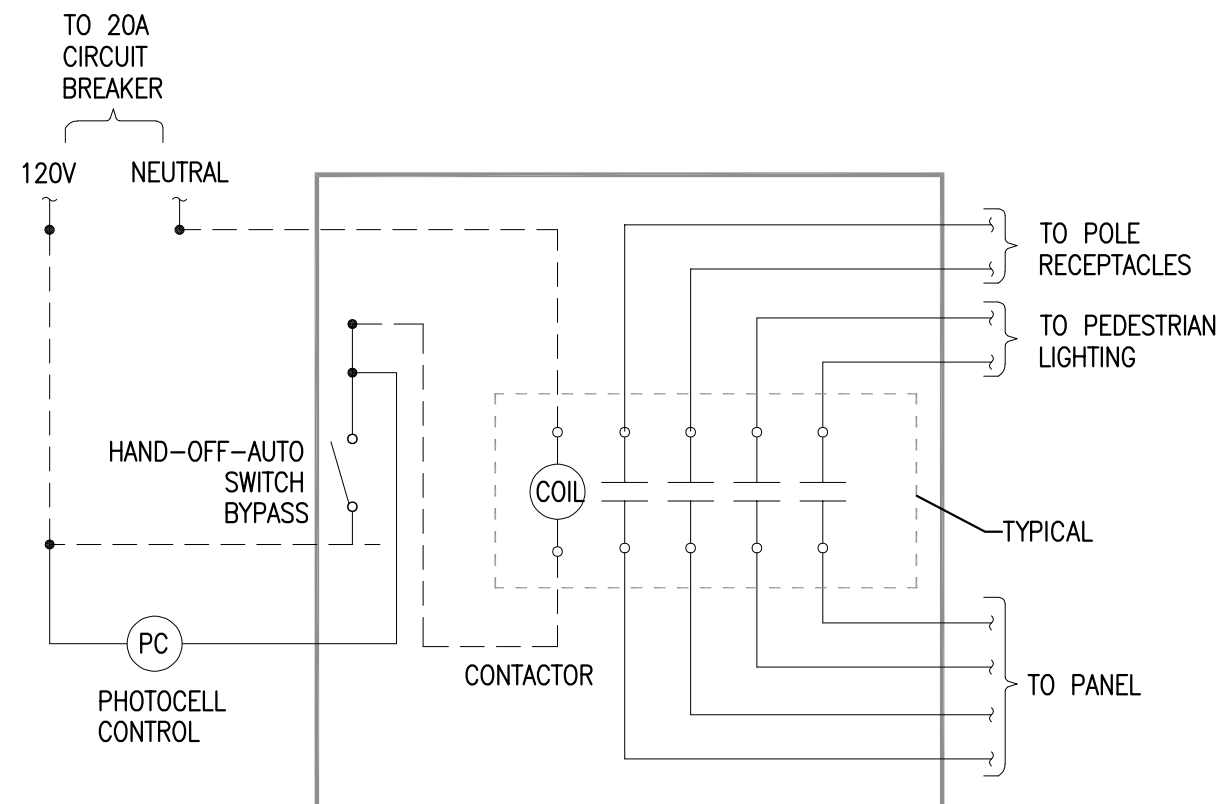

**NOTES: (DETAIL 1 ONLY)**

- A. COORDINATE CONTACTOR QUANTITY REQUIREMENTS WITH PLANS.
  - B. PROVIDE CONTACTOR IN NEMA 1 ENCLOSURE INSTALLED WITHIN SERVICE CABINET
- ① LIGHTING CONTROL DETAIL  
NOT TO SCALE

INTERIM REVIEW

DOCUMENT INCOMPLETE. NOT INTENDED FOR PERMIT, BIDDING OR CONSTRUCTION.

ENGINEER: TRAVIS E. WILTSHIRE

P.E. SERIAL NO: 85219

COMPANY NAME: CNG ENGINEERING, PLLC.

COMPANY REG. NO. F-7964

DATE: 01-20-2023

REV. NO.	DATE	DESCRIPTION	BY

**CNG ENGINEERING**  
MEP DESIGN | PLANNING | COMMISSIONING

1917 N NEW BRAUNFELS AVE, SUITE 201  
SAN ANTONIO, TEXAS 78208  
T 210.224.8841 F 210.224.8224  
www.cngengineering.com  
TBPE FIRM # F-7964

**PAPE-DAWSON ENGINEERS**

SAN ANTONIO | AUSTIN | HOUSTON | FORT WORTH | DALLAS  
2000 NW LOOP 410 | SAN ANTONIO, TX 78218 | 210.375.9000  
TEXAS ENGINEERING FIRM #170 | TEXAS SURVEYING FIRM #10028800

CITY OF SAN ANTONIO  
**PUBLIC WORKS DEPARTMENT**

DOLOROSA  
ELECTRICAL DETAIL  
LIGHTING CONTROLS

DESIGN	CHECKED	DRAWN	PROJECT NO.	SUBMITTAL	SHEET NO.
JC	JC	CDC	23-03763	70%	404

# LIGHTING FIXTURE SCHEDULE

TYPE	LAMPS	MOUNTING	VOLTS	WATTS	DESCRIPTION	MANUFACTURER & MODEL
A	LED 3000K 80 CRI (STD)	POLE	208	67	EXELIA TRITEC LED HEAD, SYMMETRIC DISTRIBUTION, SILVER REFLECTOR, TRIPLE STACK, SILVER FINISH. 10' MODULAR POLE WITH SILVER FINISH. 3' DESIGN VOID TO BEGIN AT 4.5' AND END AT 7.5' AWAY FROM GRADE WITH 90 DEGREE ORIENTATION TO HANDHOLE. FACTORY-INSTALLED GFCI RECEPTACLE IN LOCKABLE, WEATHERPROOFWHILE-IN-USE COVER INSTALLED ABOVE THE DESIGN VOID. COORDINATE DESIGN VOID ACCENT COLOR WITH LANDSCAPE ARCHITECT.	LAMP: SELUX MEXTL-TS-S1G3-30-SV-UNV POLE: SELUX MCB-10-DV3G SV-SP-REC2UP

	Project 20-38804-3 COSA Zona Cultural Streets	Catalog Number MEXTL-TS-S1G3-40-SV-120-HL30	Type <b>A</b>
	Submitted By SPECTRUM LIGHTING INC	Notes	

	Project 20-38804-3 COSA Zona Cultural Streets	Catalog Number MCB-10-DV3XX-SV-REC2-PC-CN218027	Type <b>A</b>
	Submitted By SPECTRUM LIGHTING INC	Notes	

selux

**Exelia  
Tritec LED**



Order Code: EXTL - TS - 40 - SV - 120 - HL30

EXTL	Series	EXTL <small>Exe to Tritec LED</small>								
	Nominal Overall Height	08 8 ft	09 9 ft	10 10 ft	11 11 ft	12 12 ft	13 13 ft	14 14 ft		
	TS	Optics								
		TS <small>Tritec Symmetric</small>	TA <small>Tritec Asymmetric</small>							
	S1G3	Light Engine								
		S1G1 <small>Silver Reflector, 24W, Single Stack</small>	S1G2 <small>Silver Reflector, 50W, Double Stack</small>	S1G3 <small>Silver Reflector, 67W, Triple Stack</small>	S1G4 <small>Silver Reflector, 91W, Quadruple Stack</small>	G1G1 <small>Gold Reflector, 24W, Single Stack</small>	G1G2 <small>Gold Reflector, 50W, Double Stack</small>	G1G3 <small>Gold Reflector, 67W, Triple Stack</small>	G1G4 <small>Gold Reflector, 91W, Quad-up Stack</small>	<small>*Based on (*) optics</small>
	40	CCT								
		22 2200K	27 2700K	30 3000K	40 4000K					
	SV	Finish								
		WH White	BK Black	BL Semi-Matte Black	BZ Bronze	SV Silver	SP Specify Premium Color			
	120	Voltage								
		UNV 120-277V	120 <sup>1</sup> 120V	240 <sup>1</sup> 240V	277 <sup>1</sup> 277V	547 <sup>1,3</sup> 547V	480 <sup>1,3</sup> 480V	<small><sup>1</sup>Specify for HL option <sup>2</sup>Requires step-down transformer <sup>3</sup>Not available with H-LED</small>		
	HL30	Options								
		DM <small>Dimming (0-10V)</small>	HL30 <sup>4,5</sup> <small>HiLo Switching Low Output 50%</small>	HL50 <sup>4,5</sup> <small>HiLo Switching Low Output 50%</small>	H5 <small>House Side Shield</small>	V1 <small>Vibration Damper (see page 4)</small>	PC <small>Protocol</small>	BP <small>Blue Prism Ring Optic Accessory</small>	RP <small>Red Prism Ring Optic Accessory</small>	<small><sup>4</sup>120V, 240V, &amp; 277V only <sup>5</sup>Cannot be combined with DM <sup>6</sup>See page 4 for details</small>
		REC <sup>3</sup> <small>GFCI Receptacle with weatherproof cover</small>	REC2 <sup>6</sup> <small>GFCI Receptacle with padlockable in-use cover</small>	REC3 <sup>6</sup> <small>USB &amp; Duplex Receptacle with weatherproof cover</small>	REC4 <sup>6</sup> <small>USB &amp; Duplex Receptacle with weatherproof padlockable in-use cover</small>	MS <sup>7</sup> <small>Motion Sensor with optional photocell (see page 4)</small>				

**Product Modifications**  
Please list modification requirements for review by factory:

**Approvals**

Date: \_\_\_\_\_



Selux Corporation © 2018, T 845-834-1400, 800-735-8927, F 845-834-1401, www.selux.us  
In a continuing effort to offer the best product possible, we reserve the right to change, without notice, specifications or materials that in our opinion will not alter the function of the product. Specification sheets found at www.selux.us are the most recent versions and supersede all other printed or electronic versions.

Page 1 of 9  
(Rev. 04/2021)  
EXTL\_Tritec\_ss\_26

selux

**Modular Column**



Order Code: MCB - 10 - DV3xx - SV - REC

MCB	Series	MCB Modular Column												
	10	Column Body Height												
		7 7ft	8 8ft	9 9ft	10 10ft	11 11ft	12 12ft	13 13ft	14 14ft	15 15ft	16 16ft	17 17ft	18 18ft	<small><sup>1</sup> Maximal overall height cannot exceed 18ft <sup>2</sup> For use with TC option only <sup>3</sup> Refer to page 2 for mounting option details</small>
	DV3xx	Column Features												
		CMxx <small>Column</small>	SPxx <small>Spacer</small>	FMSxx <sup>2,4,6</sup> <small>Facade Module Small Opening</small>	FMLxx <sup>2,4,6</sup> <small>Facade Module Large Opening</small>	TMSxx <sup>2,5,6</sup> <small>Twin Spot Module Single</small>	TMDxx <sup>2,5,6</sup> <small>Twin Spot Module Double</small>	<small><sup>3</sup> Cannot be mounted within 8 ft of ground <sup>4</sup> Select up to 2 FMS and FML combined <sup>5</sup> Select up to 5 TMS or up to 1 TMD and 1 TMS combined <sup>6</sup> Select up to 1 FMS/FML and 1 TMS/TMD combined <sup>7</sup> Not field adaptable for modular <sup>8</sup> Refer to page 2 for mounting option details</small>						
	SV	Finish												
		WH White	BK Black	BZ Bronze	SV Silver	BL Semi-Matte Black	SP Specify Premium Color							
	REC2-PC	Options												
		REC <small>120V GFCI Receptacle w/ weatherproof cover</small>	REC2 <small>120V GFCI Receptacle w/ in-use cover</small>	MSxx <sup>6</sup> <small>Motion Sensor w/ optional photocell (Meets T=24 requirements) See p. 6 for order code</small>	TC <sup>9</sup> <small>Top Cover (non-lit)</small>	PC <small>Butterfly-style photocell</small>	<small><sup>8</sup> Include angular orientation on page 6 <sup>9</sup> Not field adaptable to a ft top</small>							
		REC3 <small>USB &amp; Duplex Receptacle with weatherproof cover</small>	REC4 <small>USB &amp; Duplex Receptacle with weatherproof padlockable in-use cover</small>											

**Product Modifications**  
Please list modification requirements for review by factory:

**10ft modular column base with REC2 in nonstandard location and 36" design void painted in separate color**

**Approvals**

Date: \_\_\_\_\_



Selux Corporation © 2018, T 845-834-1400, 800-735-8927, F 845-834-1401, www.selux.us  
In a continuing effort to offer the best product possible, we reserve the right to change, without notice, specifications or materials that in our opinion will not alter the function of the product. Specification sheets found at www.selux.us are the most recent versions and supersede all other printed or electronic versions.

Page 1 of 10  
(Rev. 02/2020)  
MCB\_ss\_v1.3

INTERIM REVIEW

DOCUMENT INCOMPLETE. NOT INTENDED FOR PERMIT, BIDDING OR CONSTRUCTION.

ENGINEER: TRAVIS E. WILTSHIRE

P.E. SERIAL NO: 85219

COMPANY NAME: CNG ENGINEERING, PLLC.

COMPANY REG. NO. F-7964

DATE: 01-20-2023

REV. NO.	DATE	DESCRIPTION	BY

CNG ENGINEERING

MEP DESIGN | PLANNING | COMMISSIONING

1917 N NEW BRAUNFELS AVE, SUITE 201  
SAN ANTONIO, TEXAS 78208  
T 210.224.8841 F 210.224.8224  
www.cngengineering.com  
TBPE FIRM # F-7964

PAPE-DAWSON ENGINEERS

SAN ANTONIO | AUSTIN | HOUSTON | FORT WORTH | DALLAS  
2000 NW LOOP 410 | SAN ANTONIO, TX 78218 | 210.375.9000  
TEXAS ENGINEERING FIRM #170 | TEXAS SURVEYING FIRM #10028800

CITY OF SAN ANTONIO  
**PUBLIC WORKS DEPARTMENT**

DOLOROSA  
LIGHTING FIXTURE  
SCHEDULE AND FIXTURE  
CUT SHEET

DESIGN	CHECKED	DRAWN	PROJECT NO.	SUBMITTAL	SHEET NO.
JC	JC	CDC	23-03763	70%	405

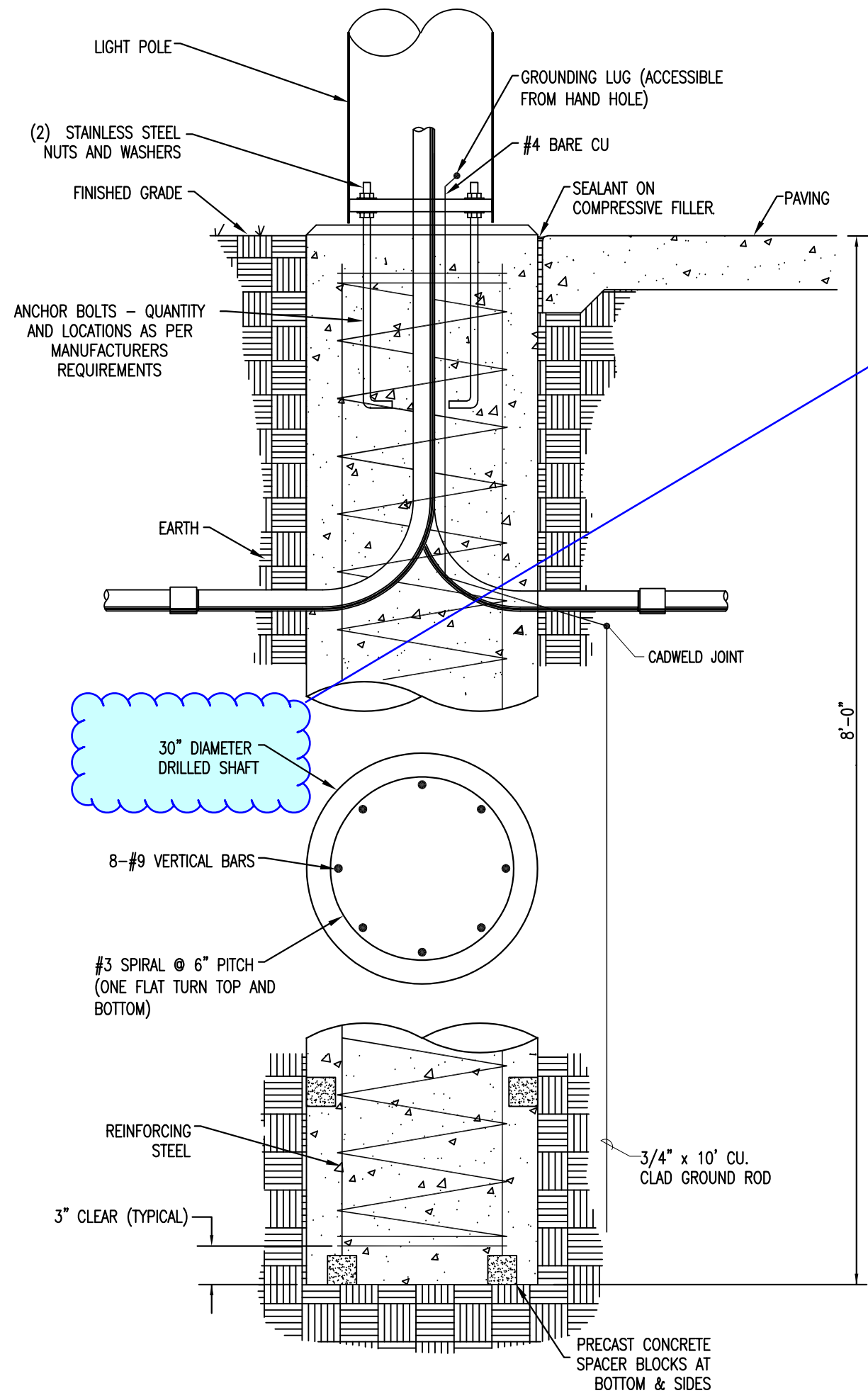

Can this foundation be reduced either in depth or diameter? Zona plans included 5ft deep, 24" diameter foundation

NOTES: (DETAIL 1 ONLY)

- A. MOUNT SELUX PEDESTRIAN MODULAR COLUMN AS PER MANUFACTURER'S INSTRUCTIONS. USE STAINLESS STEEL ANCHOR BOLTS, WASHERS AND NUTS. INSTALL ANCHOR BOLTS PRIOR TO POURING CONCRETE; SET BOLTS USING MANUFACTURER'S TEMPLATE.
- B. CONTRACTOR TO VERIFY EXISTING CONDITIONS PRIOR TO CONSTRUCTION OR ORDERING MATERIALS.
- C. CASING MAY BE REQUIRED TO CONTROL CAVING AND/OR GROUNDWATER INFLOW. IF REQUIRED CONTRACTOR SHALL FURNISH AND INSTALL CASING AT NO ADDITIONAL COST.
- D. PROVIDE RUBBED FINISH AT EXPOSED SURFACE OF BASE.
- E. PROVIDE 1" CHAMFER FINISH AT TOP EDGE.
- F. CONDUIT WITHIN CONCRETE BASE SHALL BE RIGID GALVANIZED STEEL (RGS), WRAPPED WITH UL LISTED CORROSION PROTECTIVE TAPE OR PVC COATED RGS.
- G. RE: SPECIFICATIONS FOR UNDERGROUND BRANCH CONDUIT REQUIREMENTS.

1 POLE BASE FOUNDATION DETAIL  
NOT TO SCALE

INTERIM REVIEW  
DOCUMENT INCOMPLETE. NOT INTENDED FOR PERMIT, BIDDING OR CONSTRUCTION.  
ENGINEER: TRAVIS E. WILTSHIRE  
P.E. SERIAL NO: 85219  
COMPANY NAME: CNG ENGINEERING, PLLC.  
COMPANY REG. NO. F-7964  
DATE: 01-20-2023

**CNG ENGINEERING**  
MEP DESIGN | PLANNING | COMMISSIONING  
1917 N NEW BRAUNFELS AVE, SUITE 201  
SAN ANTONIO, TEXAS 78208  
T 210.224.8841 F 210.224.8224  
www.cngengineering.com  
TBPE FIRM # F-7964

**PAPE-DAWSON ENGINEERS**  
SAN ANTONIO | AUSTIN | HOUSTON | FORT WORTH | DALLAS  
2000 NW LOOP 410 | SAN ANTONIO, TX 78218 | 210.375.9000  
TEXAS ENGINEERING FIRM #170 | TEXAS SURVEYING FIRM #10028800

CITY OF SAN ANTONIO  
**PUBLIC WORKS DEPARTMENT**

DOLOROSA  
POLE BASE  
FOUNDATION DETAIL

DESIGN	CHECKED	DRAWN	PROJECT NO.	SUBMITTAL	SHEET NO.
JC	JC	CDC	23-03763	70%	406

**GENERAL NOTES:**

1. REFER TO LIGHTING FIXTURE SCHEDULE FOR LUMINAIRE POLES & BOLLARD TYPES.
2. PEDESTRIAN LIGHTING LUMINAIRES ARE INTENDED TO ILLUMINATE PEDESTRIAN WALKWAY. ROADWAY ILLUMINATION DESIGN AND SPECIFICATION IS TO BE PROVIDED BY CPS ENERGY.

**ILLUMINATION LEGEND**

PEDESTRIAN LIGHTING POLE 

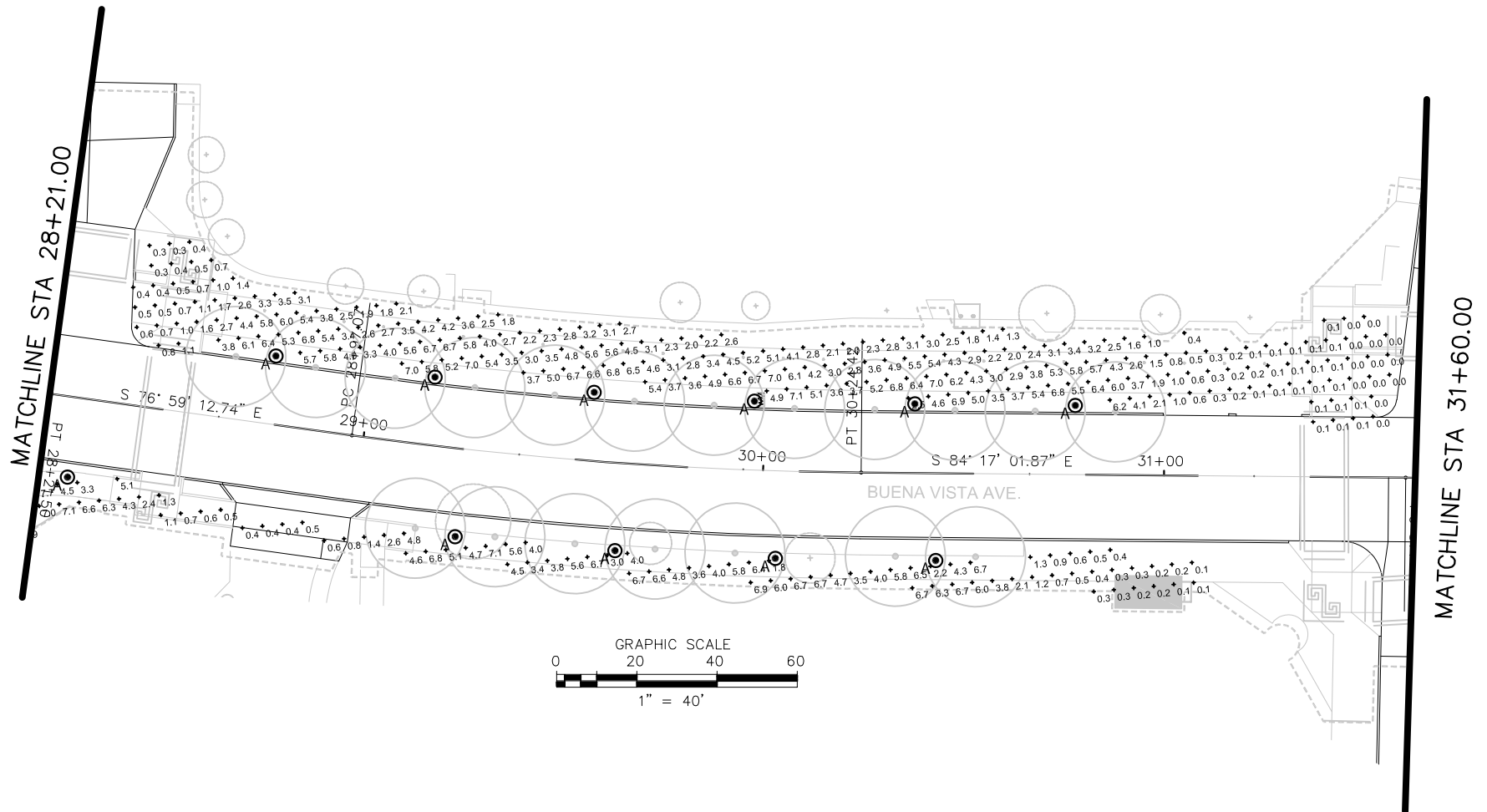
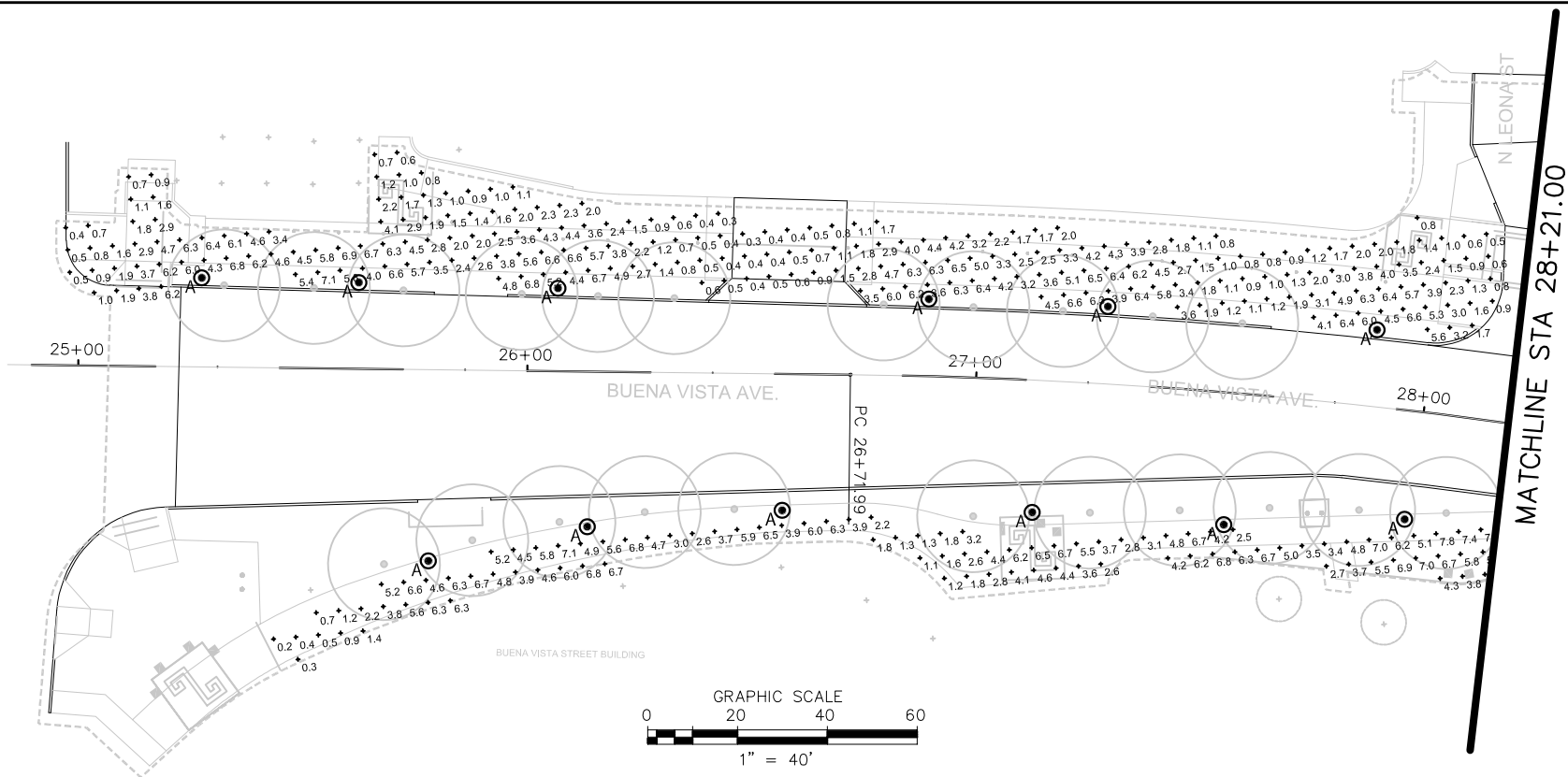

INTERIM REVIEW	
DOCUMENT INCOMPLETE. NOT INTENDED FOR PERMIT, BIDDING OR CONSTRUCTION.	
ENGINEER:	TRAVIS E. WILTSHIRE
P.E. SERIAL NO.:	85219
COMPANY NAME:	CNG ENGINEERING, PLLC.
COMPANY REG. NO.:	F-7964
DATE:	01-21-2023

REV. NO.	DATE	DESCRIPTION	BY



**CNG ENGINEERING**  
MEP DESIGN | PLANNING | COMMISSIONING

1917 N NEW BRAUNFELS AVE, SUITE 201  
 SAN ANTONIO, TEXAS 78208  
 T 210.224.8841 F 210.224.8224  
 www.cngengineering.com  
 TBPE FIRM # F-7964



**PAPE-DAWSON ENGINEERS**

SAN ANTONIO | AUSTIN | HOUSTON | FORT WORTH | DALLAS  
 2000 NW LOOP 410 | SAN ANTONIO, TX 78218 | 210.375.9000  
 TEXAS ENGINEERING FIRM #170 | TEXAS SURVEYING FIRM #10028900

CITY OF SAN ANTONIO  
**PUBLIC WORKS DEPARTMENT**

DOLOROSA  
 PHOTOMETRIC EXHIBIT

STA BEGIN TO STA 31+60.00

DESIGN	CHECKED	DRAWN	PROJECT NO.	SUBMITTAL	SHEET NO.
JC	JC	CDC	23-03763	70%	407

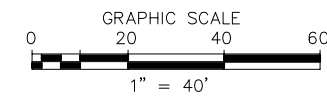
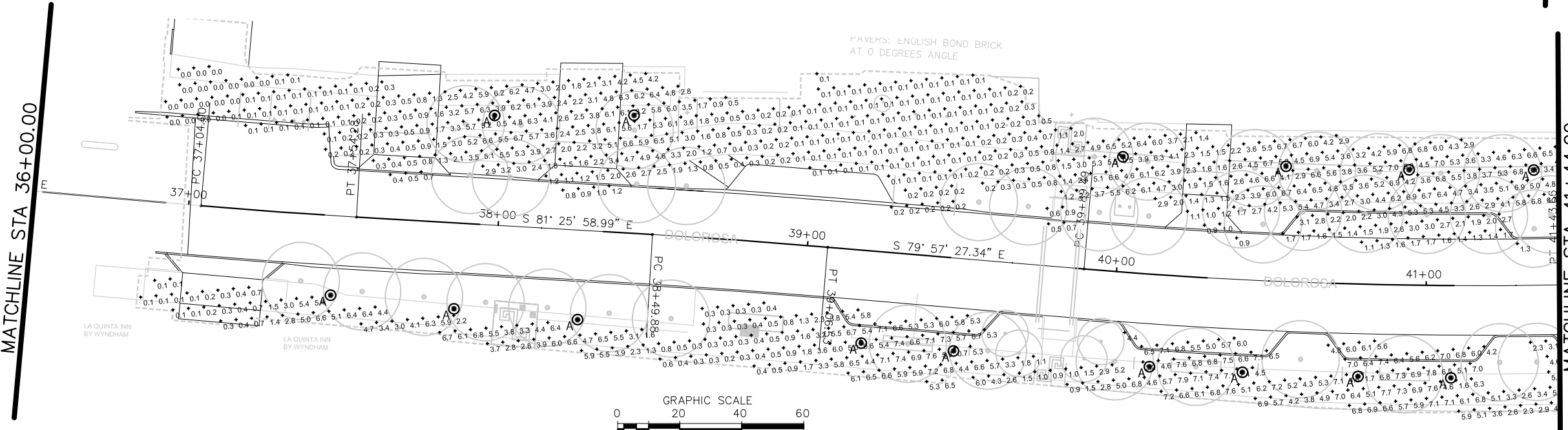
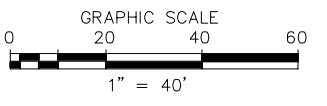
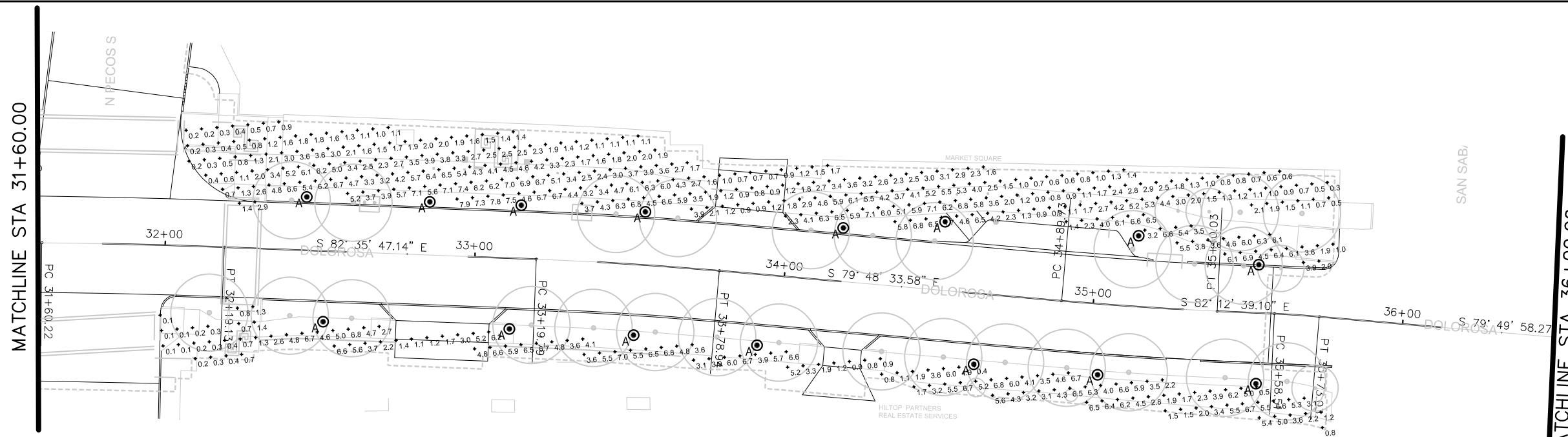

**GENERAL NOTES:**

- REFER TO LIGHTING FIXTURE SCHEDULE FOR LUMINAIRE POLES & BOLLARD TYPES.
- PEDESTRIAN LIGHTING LUMINAIRES ARE INTENDED TO ILLUMINATE PEDESTRIAN WALKWAY. ROADWAY ILLUMINATION DESIGN AND SPECIFICATION IS TO BE PROVIDED BY CPS ENERGY.

**ILLUMINATION LEGEND**

PEDESTRIAN LIGHTING POLE

INTERIM REVIEW	
DOCUMENT INCOMPLETE. NOT INTENDED FOR PERMIT, BIDDING OR CONSTRUCTION.	
ENGINEER:	TRAVIS E. WILTSHIRE
P.E. SERIAL NO.:	85219
COMPANY NAME:	CNG ENGINEERING, PLLC.
COMPANY REG. NO.:	F-7964
DATE:	01-21-2023

REV. NO.	DATE	DESCRIPTION	BY



**CNG ENGINEERING**  
 MEP DESIGN | PLANNING | COMMISSIONING  
 1917 N NEW BRAUNFELS AVE, SUITE 201  
 SAN ANTONIO, TEXAS 78208  
 T 210.224.8841 F 210.224.8224  
 www.cngengineering.com  
 TBPE FIRM # F-7964



**PAPE-DAWSON ENGINEERS**  
 SAN ANTONIO | AUSTIN | HOUSTON | FORT WORTH | DALLAS  
 2000 NW LOOP 410 | SAN ANTONIO, TX 78218 | 210.875.9000  
 TEXAS ENGINEERING FIRM #170 | TEXAS SURVEYING FIRM #10028600



CITY OF SAN ANTONIO  
**PUBLIC WORKS DEPARTMENT**

DOLOROSA  
 PHOTOMETRIC EXHIBIT

STA 31+60.00 TO STA 41+44.00

SHEET 2 OF 4

DESIGN	CHECKED	DRAWN	PROJECT NO.	SUBMITTAL	SHEET NO.
JC	JC	CDC	23-03763	70%	408

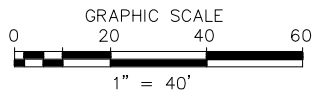
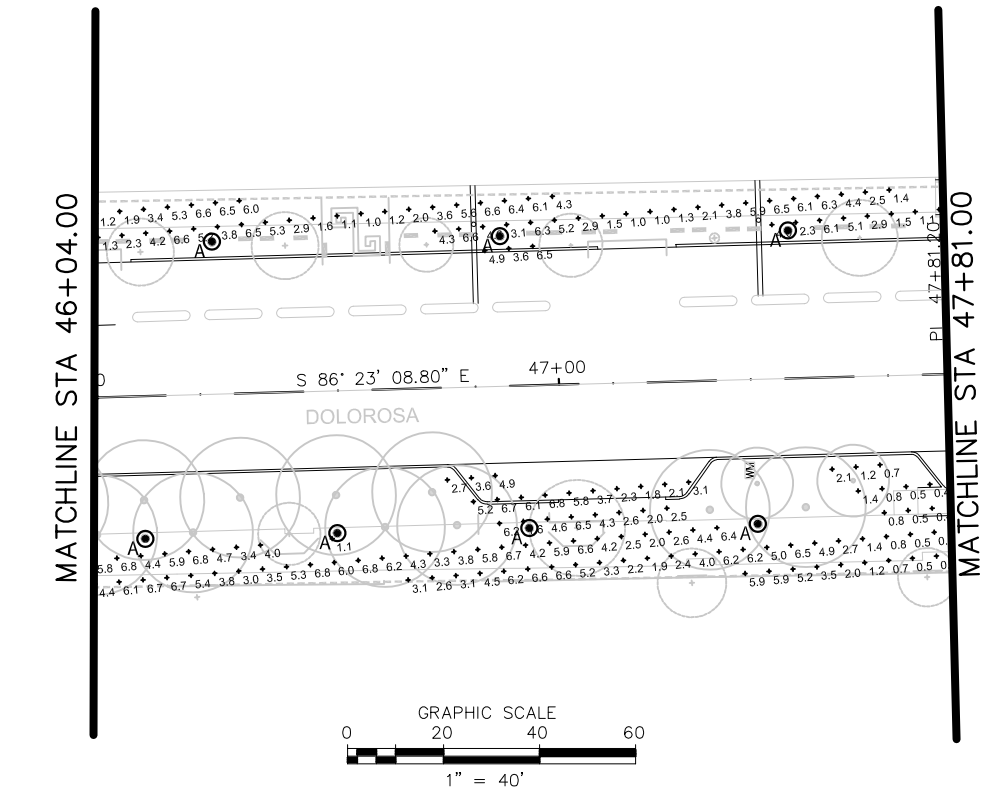
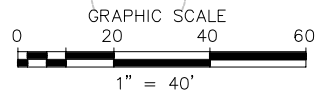
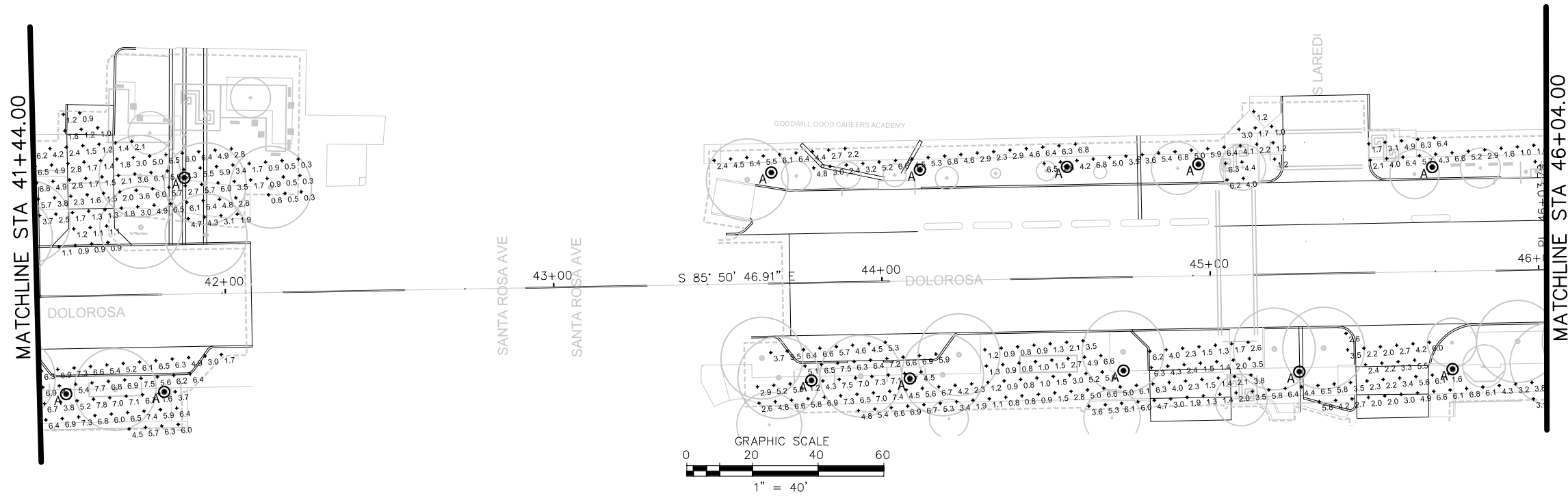

**GENERAL NOTES:**

1. REFER TO LIGHTING FIXTURE SCHEDULE FOR LUMINAIRE POLES & BOLLARD TYPES.
2. PEDESTRIAN LIGHTING LUMINAIRES ARE INTENDED TO ILLUMINATE PEDESTRIAN WALKWAY. ROADWAY ILLUMINATION DESIGN AND SPECIFICATION IS TO BE PROVIDED BY CPS ENERGY.

**ILLUMINATION LEGEND**

PEDESTRIAN LIGHTING POLE

INTERIM REVIEW	
DOCUMENT INCOMPLETE. NOT INTENDED FOR PERMIT, BIDDING OR CONSTRUCTION.	
ENGINEER:	TRAVIS E. WILTSHIRE
P.E. SERIAL NO.:	85219
COMPANY NAME:	CNG ENGINEERING, PLLC.
COMPANY REG. NO.:	F-7964
DATE:	01-21-2023

REV. NO.	DATE	DESCRIPTION	BY



**CNG ENGINEERING**  
 MEP DESIGN | PLANNING | COMMISSIONING  
 1917 N NEW BRAUNFELS AVE, SUITE 201  
 SAN ANTONIO, TEXAS 78208  
 T 210.224.8841 F 210.224.8224  
 www.cngengineering.com  
 TBPE FIRM # F-7964



**PAPE-DAWSON ENGINEERS**  
 SAN ANTONIO | AUSTIN | HOUSTON | FORT WORTH | DALLAS  
 2000 NW LOOP 410 | SAN ANTONIO, TX 78218 | 210.875.9000  
 TEXAS ENGINEERING FIRM #170 | TEXAS SURVEYING FIRM #10028800



CITY OF SAN ANTONIO  
**PUBLIC WORKS DEPARTMENT**

DOLOROSA  
 PHOTOMETRIC EXHIBIT

STA 41+44.00 TO STA 47+81.00

DESIGN	CHECKED	DRAWN	PROJECT NO.	SUBMITTAL	SHEET NO.
JC	JC	CDC	23-03763	70%	409

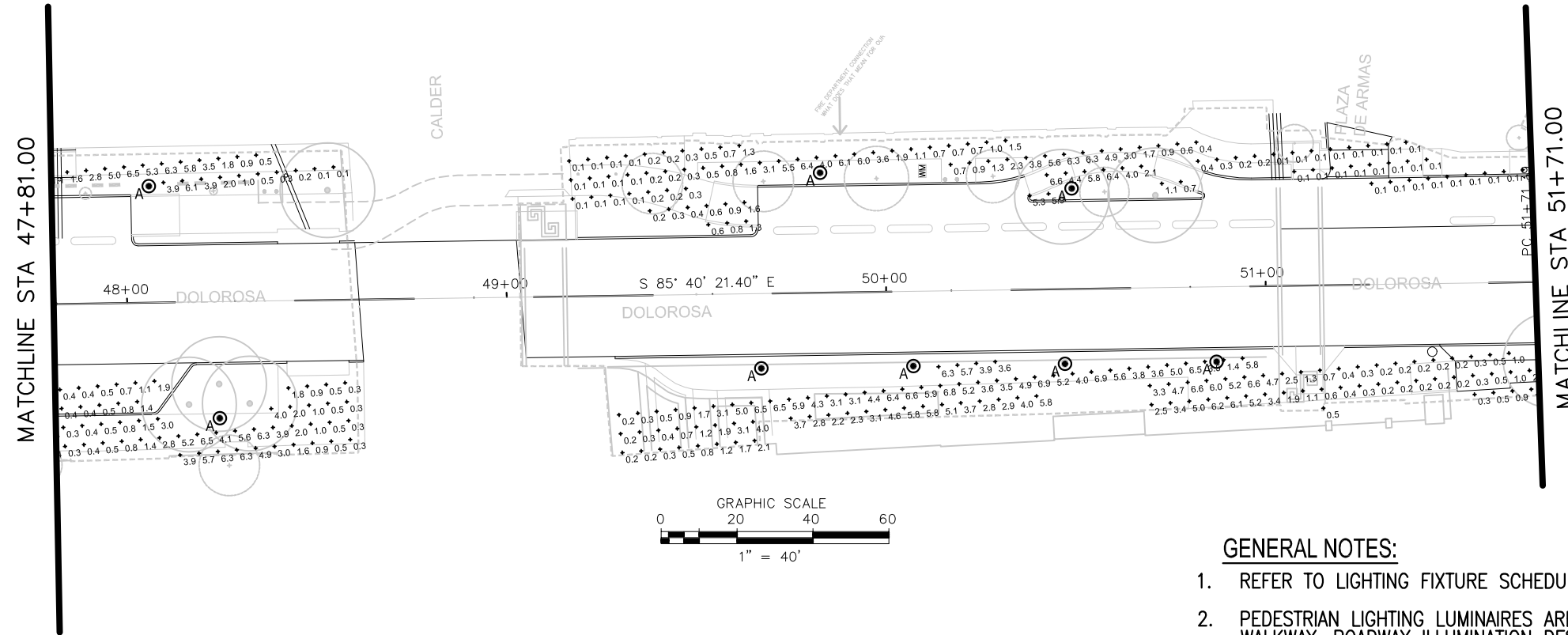

**GENERAL NOTES:**

1. REFER TO LIGHTING FIXTURE SCHEDULE FOR LUMINAIRE POLES & BOLLARD TYPES.
2. PEDESTRIAN LIGHTING LUMINAIRES ARE INTENDED TO ILLUMINATE PEDESTRIAN WALKWAY. ROADWAY ILLUMINATION DESIGN AND SPECIFICATION IS TO BE PROVIDED BY CPS ENERGY.

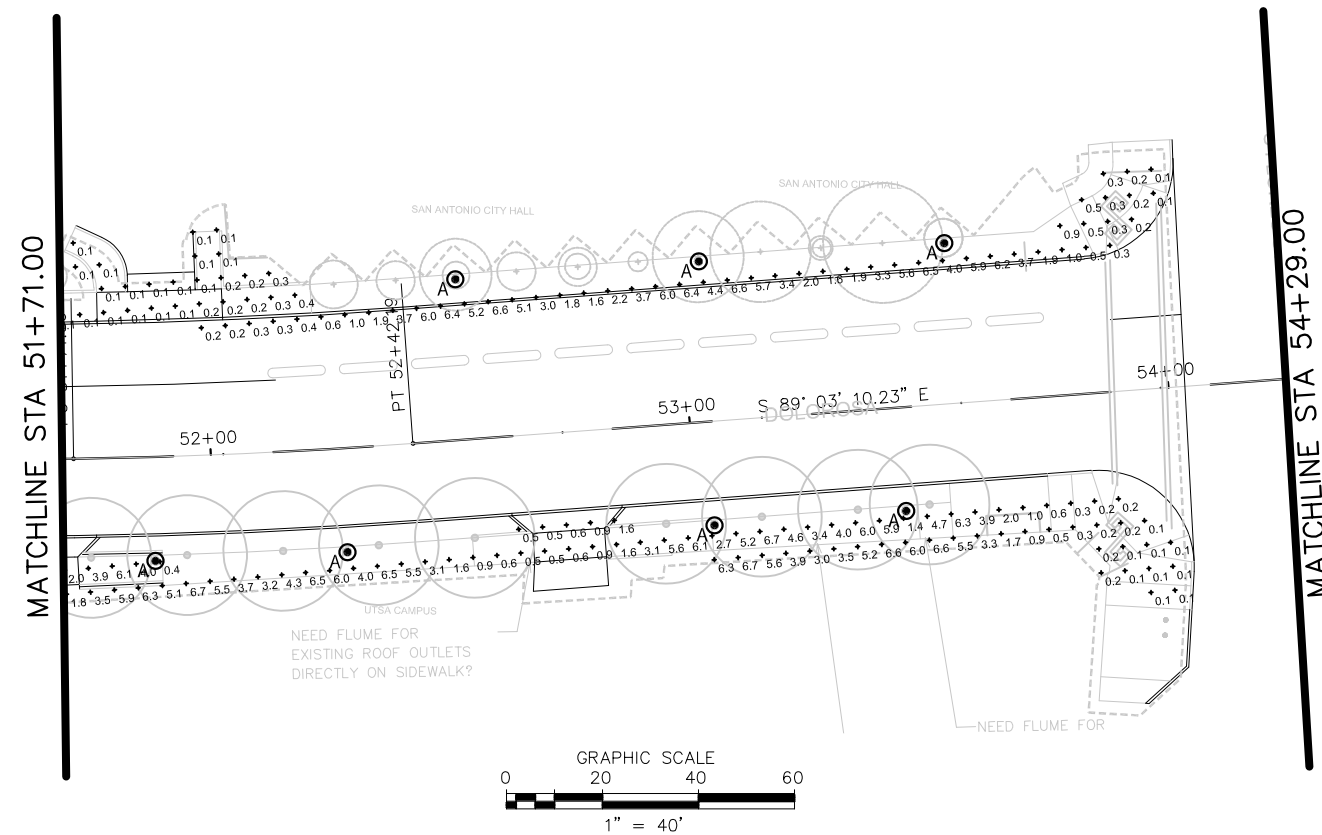

**ILLUMINATION LEGEND**

PEDESTRIAN LIGHTING POLE A

INTERIM REVIEW	
DOCUMENT INCOMPLETE. NOT INTENDED FOR PERMIT, BIDDING OR CONSTRUCTION.	
ENGINEER:	TRAVIS E. WILTSHIRE
P.E. SERIAL NO.:	85219
COMPANY NAME:	CNG ENGINEERING, PLLC.
COMPANY REG. NO.:	F-7964
DATE:	01-21-2023

REV. NO.	DATE	DESCRIPTION	BY



**CNG ENGINEERING**  
 MEP DESIGN | PLANNING | COMMISSIONING  
 1917 N NEW BRAUNFELS AVE, SUITE 201  
 SAN ANTONIO, TEXAS 78208  
 T 210.224.8841 F 210.224.8224  
 www.cngengineering.com  
 TBPE FIRM # F-7964



**PAPE-DAWSON ENGINEERS**  
 SAN ANTONIO | AUSTIN | HOUSTON | FORT WORTH | DALLAS  
 2000 NW LOOP 410 | SAN ANTONIO, TX 78218 | 210.875.9000  
 TEXAS ENGINEERING FIRM #170 | TEXAS SURVEYING FIRM #10028900



**CITY OF SAN ANTONIO  
 PUBLIC WORKS DEPARTMENT**

DOLOROSA  
 PHOTOMETRIC EXHIBIT

STA 47+81.00 TO STA 54+29.00  
 SHEET 4 OF 4

DESIGN	CHECKED	DRAWN	PROJECT NO.	SUBMITTAL	SHEET NO.
JC	JC	CDC	23-03763	70%	410