

TRAFFIC NOTES AND SPECIAL CONDITIONS

- 1.It is the contractor's sole responsibility to see that all traffic control devices are properly installed and maintained at the job site in accordance with the plans, specifications and related industry standards and regulations. These notes, do not, in of themselves, constitute a Traffic Control Plan. In the event that these plans do not include traffic control, or that the Contractor wishes to vary from traffic control included with these plans, he shall submit for review a Traffic Control Plan sealed by a Professional Engineer registered in the State of Texas, including a sign and barricade plan conforming to the requirements of the Texas Manual on Uniform Traffic Control Devices. The City's construction observer/inspector (COI) and the traffic engineering representative will only be responsible to inspect the traffic control devices being deployed. If, in the opinion of the traffic engineering representative and the COI, the traffic control devices do not conform to established standards or are incorrectly placed or are insufficient in quantity to protect the general public, the COI shall have the option to stop construction operations at no expense to the City until such time as the conditions are corrected by the contractor.
- 2.Prior to starting construction, the contractor shall contact the City of San Antonio Traffic Operations Section at 207-4586 for a traffic signal inventory, and at 207-3951 for a traffic sign inventory. Prior to completion of the contract and removal of the barricades, the contractor shall again contact the Traffic Operations Section. The barricades shall not be removed until all applicable permanent traffic signs and signals are in place.
- 3.It is the contractor's responsibility to obtain and maintain temporary stop signs and all other traffic control devices required to protect the general public. If the City of San Antonio has removed permanent stop signs, the contractor shall request that the signs be returned to the construction site to be reinstalled by the contractor. All permanent signs or traffic control devices missing or damaged upon completion of construction shall be replaced at the contractor's expense.
- 4.The contractor must contact the City's COI 48 hours in advance (not including weekends) of any minor street closure. It will be the contractor's responsibility to advise the COI 10 days in advance of and arterial total street closure. This much time is necessary to install advisory signs and give the motorists a minimum of 7 days notice of the street closure. The COI after being notified will contact the traffic engineering office to make the necessary arrangements.
- 5.As work progresses, location of temporary traffic control devices will be adjusted and modified, as necessary by the contractor at contractor's expense.
- 6.If the need arises, additional temporary traffic control devices, special directional devices, and/or business name signs may be ordered by the traffic engineering representative at the contractor's expense.
- 7.Temporary traffic control devices shall conform to the City's "Typical Sign and Barricade Standards" sheets and to the Texas Manual on Uniform Traffic Control Devices.
- 8.The contractor must maintain all streets within project limits open to through traffic by repairing trenches, potholes, leveling up with asphalt, etc. at no direct payment, with the cost to be included in other items.
- 9.The contractor shall be responsible for providing suitable access accommodations for school children and pedestrians.
- 10.The contractor shall provide access for delivery of mail by the U.S. Postal Service.
- 11.The contractor shall provide for access to residences and all businesses at all times within all the phases of the work.
- 12.When construction work necessitates the utilization of vehicle paths other than the lanes normally used, traffic control markings no longer applicable shall be removed and approved temporary pavement markings and signs installed in accordance with Part VI-D of the Texas Manual on Uniform Traffic Control Devices. After construction is completed and traffic is rerouted back to the original lanes, the traffic control markings and/or raised buttons that were originally removed from the existing pavement must be replaced. In addition, temporary markings must be removed. All of this is to be done at no direct payment; cost should be included in other items.
- 13.Permanent pavement markings shall be applied prior to the opening of the completed street to traffic. Prior to the application of permanent markings, either temporary additional short-term expendable pavement markings, or raised pavement markings may be provided to delineate continuity until such time as standard pavement markings can be. Temporary markings shall be placed at no direct payment.
- 14.All temporary traffic control devices, etc. shall be provided by the contractor without direct payment, unless otherwise noted or stated.
- 15.The COI will monitor the contractor's traffic control devices and will be responsible to furnish all residents and businesses with an information flyer on all jobs during construction.
- 16.Any damage to permanent traffic signals, the controller box, loops or conduits during or upon completion of the project shall be repaired or replaced at the contractor's expense. The decision to repair, as opposed to replace, the damaged equipment shall be made by the City's Traffic Engineer.
- 17.The contractor is responsible for repairing all streets outside of the project limits which are damaged due to construction activities. The replaced section must be approved by the City's Street Engineer. There will be no direct payment for this work. The cost is to be included in other items.
- 18.If split construction is shown, then the sanitary sewer shall be completed prior to beginning street and drainage construction, and traffic shall be maintained or detoured as directed by the Traffic Engineer. There will be no additional payment for the maintaining of traffic or detours.
- 19.The contractor shall provide the city an emergency telephone number for evenings, weekends, and holidays by the first working day of the project. This telephone number must be a commercial answering service. The answering service must be able to contact the contractor and have the contractor respond to the City staff within two hours of the initial contact.
- 20.The contractor shall maintain continuous access to all intersecting streets unless otherwise shown on these plans. When continuous access is scheduled to be blocked, the contractor shall contact the dispatchers for the Fire Department and EMS at (210)227-8341 and the Police Department at (210)207-2257, to apprise them of the pending street closure at least forty-eight hours in advance. If the closure falls along a bus route, the contractor shall also contact VIA at (210)362-5220.
- 21.The contractor shall maintain either the existing or temporary street name signs at each intersection onsite throughout construction. If the existing street name signs are used, they must be maintained in the condition encountered prior to the beginning of construction, and then be turned in to the City Inspector at the end of the project. If temporary signs are used during construction, they shall have a minimum of 4-inch letters, and may be fabricated with construction zone material (black legend on orange background, using plywood substrate, etc.).
- 22.VIA shall be responsible for all temporary bus stops and related signing. Once VIA sets up temporary bus stops contractor shall ensure signage remains visible and bus stop is accessible. Contractor to notify VIA at least 7 days in advance to phase/step change to allow coordination for VIA to get the temporary bus stops moved as needed.

Revised January, 2023

PHASING AND STAGING NOTES - STREET AND DRAINAGE CONSTRUCTION

- 1.Any questions regarding phasing or staging will be strictly handled by the Department of Public Works which has complete authority to make final decisions on any changes or modifications. The contractor must contact the City's construction inspector 48 hours in advance (not including weekends or holidays) of any minor street closure. It will be the contractor's responsibility to advise Construction Inspections ten (10) days in advance of any arterial street closure. This much time is necessary to install advisory signs and give the motorists a minimum of seven (7) days notice before street closure. The construction inspector, after having been notified, will contact the engineering office immediately to make the necessary arrangements. The temporary barricades and warning signs shall be located so as to afford the maximum protection to the public as well as construction personnel and equipment and to facilitate an expeditious flow of traffic at all times during construction.
- 2.If there are two (2) or more phases in the project, no more than two (2) phases of construction may be worked at one time, unless otherwise indicated in the plans. Partial construction at different scattered locations within the project will not be allowed. Projects that consist of distinct and separate areas may be under construction at the same time with an approved field alteration. All remaining streets within the project or separate area shall remain open at all times.
- 3.Unless otherwise indicated in the plans, two (2) phases in sequence may be worked at the same time, in projects where there are at least three (3) phases. Such as Phase 1 and Phase 2 and before going to Phase 3, Phase 1 must be completed 100% with base material and approved densities (prime coated if base material is Item No. 200 "Flexible Base") before beginning Phase 3. If there are only two (2) phases in the project, Phase 1 must be completed 100% with base material and approved densities (prime coated if base material is item No. 200 "Flexible Base") before proceeding to Phase 2.
- 4.If the project has more than sixteen (16) phases, before the contractor can begin Phase 17, he must completely finish with Type "B" or Type "D" asphalt at least 50% of the lower phases he has worked on. (Example: If the project has 20 phases, before the contractor can start construction of Phase 17, he must finish Type "B" or Type "D" asphalt up to Phase 8.).
- 5.The plans are phased for street and storm drainage construction. No storm sewer construction will take place outside of the phasing limits under construction, unless specifically noted on the plans or authorized in writing by the Traffic Division.
- 6.All storm drainage pipes are not considered utilities, regardless of size. This work shall be part of the Phase.
- 7.Unless otherwise indicated in the plans, intersecting streets shall be constructed in stages so as to maintain access. Intersection work shall be done during weekend hours or as directed by the Engineer. No two adjacent intersections may be constructed simultaneously. With approval from the Engineer, the Contractor may close an entire intersection. The Contractor will be required to provide a detour plan for such a closure to the Engineer for approval.

Revised Nov. 2002

Revise language to include Phase/Step. We do not want to indicate to the contractor that they can work in both Phase 1 - Step 1 simultaneously with Phase 2

CITY OF SAN ANTONIO PUBLIC WORKS DEPARTMENT			
TRAFFIC CONTROL PLAN GENERAL NOTES			
70% SUBMITTAL	PROJECT NO.: 23-03763	DATE: 1/23/2023	
DRWN. BY:	DSGN. BY:	CHKD. BY:	SHEET NO.: 34 OF 521

SEQUENCE OF WORK NARRATIVE

NOTES

INSTALL PROJECT LIMIT AND ADVANCE WARNING SIGNS ALONG DOLOROSA AND ALL SIDE STREETS AS SHOWN ON THE TRAFFIC CONTROL PLANS (TCP). ALL SIGNS AND BARRICADES SHALL BE IN ACCORDANCE WITH THE TEXAS MANUAL ON UNIFORM TRAFFIC CONTROL DEVICES (TMUTCD), CITY OF SAN ANTONIO STANDARDS AND/OR AS DIRECTED BY THE ENGINEER. THESE SIGNS SHALL BE ERECTED AND PLACED PRIOR TO COMMENCING ANY PROPOSED CONSTRUCTION AND SHALL REMAIN IN PLACE FOR THE DURATION OF THE PROJECT AND UNTIL COMPLETION AND ACCEPTANCE OF THE PROJECT BY THE CITY OF SAN ANTONIO.

THE CONTRACTOR SHALL BE RESPONSIBLE FOR MAINTAINING TRAFFIC SIGNAL OPERATIONS AND DETECTION THROUGHOUT ALL PHASES OF CONSTRUCTION.

PRIOR TO AND/OR DURING EACH APPROPRIATE PHASE OF CONSTRUCTION, PROVIDE APPROPRIATE TRAFFIC CONTROL DEVICES AND SIGNING AS REQUIRED. THE RESTORATION OF THE ALL-WEATHER SURFACE ROADWAY CROSSINGS WILL NOT BE PAID FOR DIRECTLY BUT SHALL BE CONSIDERED SUBSIDIARY TO THE VARIOUS BID ITEMS.

THE CONTRACTOR SHALL BE RESPONSIBLE FOR MAINTAINING POSITIVE DRAINAGE AT ALL TIMES DURING CONSTRUCTION. INSTALL SILT FENCES AND ANY OTHER REQUIRED STORM WATER POLLUTION PREVENTION (SW3P) STRUCTURES AS SHOWN ON TCP SHEETS AND/OR THE SW3P LAYOUTS AND STANDARDS.

ROADWAY ACCESS TO ALL INTERSECTING ROADWAYS AND DRIVEWAYS SHALL BE MAINTAINED AT ALL TIMES DURING CONSTRUCTION EXCEPT AS SHOWN IN DETOUR LAYOUTS OR AS DIRECTED BY THE ENGINEER. THE ENGINEER MAY DIRECT THE CONTRACTOR TO VARY THE NUMBER AND LOCATION OF SIGNS AND BARRICADES FROM THAT INDICATED IN THE PLANS.

WORK HOURS FOR THIS PROJECT ARE FROM SUNRISE TO SUNSET, 6 DAYS A WEEK.

WEEKEND HOURS ARE DEFINED AS THE HOURS FROM FRIDAY 7:00 PM TO MONDAY 6:00 AM.

NIGHT-TIME HOURS ARE DEFINED AS FROM 7:00 PM TO 6:00 AM BEGINNING ON MONDAY EVENING THROUGH FRIDAY MORNING.

OFF-PEAK HOURS ARE DEFINED AS FROM 9:00 AM TO 2:00 PM FROM MONDAY THROUGH FRIDAY.

ALL UTILITY TIE-INS SHALL BE DONE DURING OFF PEAK HOURS FOR ALL PHASES OF CONSTRUCTION UNLESS OTHERWISE APPROVED BY THE CITY AND PROJECT ENGINEER.

CONTRACTOR TO ENSURE CONSTRUCTION PERIMETER FENCING SHALL BE PLACED NEAR BACK OF CURB DURING ALL PHASES TO ALLOW FOR PEDESTRIANS TO MAINTAIN ACCESS TO SIDEWALK WHEN CONSTRUCTION IS NOT OCCURRING IN IMMEDIATE AREA.

PHASE 1 - STEP 1 (STA 25+20 TO STA 31+30)

INSTALL APPROPRIATE TRAFFIC CONTROL DEVICES AND SIGNING AS SHOWN ON THE ADVANCED WARNING SIGN LAYOUT, TCP LAYOUTS AND TYPICAL SECTIONS.

BUENA VISTA (DOLOROSA) THROUGH TRAFFIC WILL CONSIST OF A SINGLE LANE OF TRAFFIC ALONG THE NORTHERN MOST LANE. PAVEMENT MARKINGS WILL BE ELIMINATED FROM STA 25+20 TO STA 30+00(NSPI.)

-BUENA VISTA TRAFFIC ENTERING THE PROJECT WILL BE REDUCED TO A SINGLE LANE OF TRAFFIC (NORTHERN MOST LANE.)

-S MEDINA WILL BE TEMPORARILY CONVERTED TO TWO WAY TRAFFIC. S MEDINA TRAFFIC ACCESSING BUENA VISTA WILL BE DETOURED TO UTILIZE FRIO. (SEE DETOUR LAYOUT)

-CLOSE VIA EXISTING BUS STOP 86883 (STA 31+00) AND OPEN A TEMPORARY BUS STOP LOCATED AT STA 33+75.

-VIA TO DETOUR ALL S MEDINA ROUTES ONTO COMMERCE ST THROUGHOUT THIS PHASE.

-EXISTING PEDESTRIAN CROSSING BUENA VISTA AT S. LEONA DETOURED TO CROSS AT EITHER FRIO OR S PECOS-LA TRINIDAD INTERSECTIONS.

-BUENA VISTA SIDEWALKS ALONG THE SOUTH SIDE WILL BE CLOSED. THIS CLOSURE INCLUDES NO ACCESS TO THE UTSA CAMPUS BUILDING. PEDESTRIANS THAT NEED TO ACCESS THE BUILDING WILL ACCESS IT FROM THE FRIO ENTRANCE DURING PHASE 1 STEP 1.

-PEDESTRIANS WILL BE DETOURED AROUND CONSTRUCTION ZONE TO CROSS BUENA VISTA AT FRIO AND S PECOS-LA TRINIDAD AND USE THE NORTHERN EXISTING SIDEWALK.

CONSTRUCT THE WATER MAIN FROM STA 26+68 TO STA 31+30 DURING NORMAL CONSTRUCTION HOURS. THIS INCLUDES INSTALLING A WATER LINE LATERAL AT STA 27+97 UP TO THE WORK ZONE LIMITS. A TEMPORARY JUMPER CONNECTION WILL BE INSTALLED TO TIE THE NEW LATERAL LINE INTO THE EXISTING LATERAL LINE (STA 28+15.) CONSTRUCT THE WATER MAIN FROM STA 31+30 TO STA 31+96 UTILIZING NIGHT/WEEKEND WORK, CUT & RESTORE PAVEMENT, UTILIZE SINGLE LANE CLOSURES TO CROSS THE INTERSECTION. BRING THIS SECTION OF THE WATER LINE ONLINE.

PHASE 1 - STEP 1 (STA 25+20 TO STA 31+30) CONT.

CONSTRUCT THE SOUTH (RIGHT) SIDE OF BUENA VISTA FROM STA 25+20 TO STA 31+30, INCLUDING PROPOSED CONDUITS, CPS DUCT BANK, PROPOSED STORM SEWER, MANHOLE ADJUSTMENTS, CURB, SIDEWALK, DRIVEWAYS, CONCRETE PAVEMENT SECTION, LANDSCAPED AREAS AND IRRIGATION LINES AS SHOWN ON THE TCP LAYOUTS AND TYPICAL SECTIONS AND AS PER THE CONSTRUCTION PLANS.

BEFORE PHASE/STEP COMPLETION, CONTRACTOR TO CLOSE OUTSIDE LANE ALONG FRIO AS SHOWN IN THE INTERSECTION CLOSURE SHEET TO ALLOW FOR ACCELERATED CONSTRUCTION OF SOUTHEAST CORNER OF BUENA VISTA AND FRIO. A SINGLE PEDESTRIAN RAMP WILL NEED TO REMAIN OPEN AT ALL TIMES DURING THIS OPERATION TO ALLOW FOR PEDESTRIANS TO TRAVERSE THROUGH THE INTERSECTION.

INTERSECTION CONSTRUCTION AT DOLOROSA AND S PECOS-LA TRINIDAD SHALL BE COMPLETED WITH ACCELERATED CONSTRUCTION AS SHOWN ON THE TCP INTERSECTION CLOSURE LAYOUTS/CONSTRUCTION PLANS. CONSTRUCTION WILL INCLUDE CPS DUCT BANK, CURB, SIDEWALK AND CONCRETE PAVEMENT SECTION. DETOUR PEDESTRIANS TO W NUEVA ST DURING THE CONSTRUCTION OF THIS INTERSECTION. ONCE THE INTERSECTION HAS BEEN COMPLETED, THE NEXT PHASE/STEP CAN BE STARTED.

PHASE 1 - STEP 2 (STA 26+50 TO STA 45+75)

INSTALL APPROPRIATE TRAFFIC CONTROL DEVICES AND SIGNING AS SHOWN ON THE ADVANCED WARNING SIGN LAYOUT, TCP LAYOUTS AND TYPICAL SECTIONS.

DOLOROSA THROUGH TRAFFIC WILL CONSIST OF A SINGLE LANE OF TRAFFIC ALONG THE NORTHERN MOST LANE WITH A SINGLE RIGHT TURN/BUS LOADING LANE.

-MAINTAIN PHASE 1 STEP 1 BARRICADES AND TCP APPURTENANCES FROM THE BEGINNING OF THE PROJECT UP TO STATION 29+50.

-PHASE 1 STEP 1 BARRIER TO BE REMOVED FROM STA 29+50 TO STA 30+25 TO ALLOW FOR A DIVORCED RIGHT TURN MOVEMENT AT THE FRIO INTERSECTION. SEE TCP LAYOUTS FOR ADDITIONAL INFORMATION.

-PAVEMENT MARKINGS TO BE ELIMINATED FROM STA 32+25 TO STA 42+00 AS SHOWN IN TCP LAYOUTS (NSPI.)

-VIA TO OPEN PROPOSED BUS STOP 86883 (STA 31+00) AND CLOSE TEMPORARY BUS STOP LOCATED AT STA 33+75. VIA BUS WILL UTILIZE RIGHT TURN LANE FOR LOADING/UNLOADING. A BUS QUEUE JUMP WILL BE ADDED TO THE TRAFFIC SIGNAL TO ALLOW FOR BUSES TO CROSS THROUGH S PECOS-LA TRINIDAD AND PROCEED THROUGH CONSTRUCTION ZONE.

-VIA TO CLOSE EXISTING BUS STOP 87823 (STA 38+90) AND OPEN A TEMPORARY BUS STOP LOCATED AT THE EXISTING BUS STOP 88913 (STA 44+50.) BUS STOP 88913 WILL REMAIN OPEN AND ALSO SERVICE RIDERSHIP FOR 87823 THROUGHOUT THIS STEP.

-PERIMETER CONSTRUCTION FENCING WILL BE RELOCATED TO CURB LINE FROM STA 25+20 TO STA 30+00 TO ALLOW FOR PEDESTRIANS TO UTILIZE PREVIOUSLY CONSTRUCTED SIDEWALK ON SOUTHERN (RIGHT) SIDE.

-EXISTING PEDESTRIAN CROSSING BUENA VISTA AT S. LEONA WILL REMAIN CLOSED AND DETOURED TO CROSS AT EITHER FRIO OR S PECOS-LA TRINIDAD.

-EXISTING PEDESTRIAN CROSSING DOLOROSA AT MIDBLOCK WILL BE CLOSED AND DETOURED TO CROSS AT EITHER SAN SABA OR SANTA ROSA.

-SIDEWALK ALONG SOUTHERN (RIGHT) SIDE WILL BE CLOSED. PEDESTRIANS WILL BE DETOURED TO THE NORTH SIDE SIDEWALK WITH PEDESTRIAN CROSSINGS AT S PECOS-LA TRINIDAD, SAN SABA, AND SANTA ROSA.

CONSTRUCT THE WATER MAIN FROM STA 33+84 TO STA 35+25 DURING NORMAL CONSTRUCTION HOURS. BRING THIS SECTION OF WATER LINE ONLINE.

CONSTRUCT THE WATER MAIN FROM STA 36+90 TO STA 42+04 DURING NORMAL CONSTRUCTION HOURS. BRING THIS SECTION OF WATER LINE ONLINE.

CONSTRUCT THE SOUTH (RIGHT) SIDE OF DOLOROSA FROM STA 32+50 TO STA 41+90, INCLUDING PROPOSED STORM SEWER, MANHOLE ADJUSTMENTS, PROPOSED CONDUITS, CPS DUCT BANK, CURB, SIDEWALK, DRIVEWAYS, CONCRETE PAVEMENT SECTION, LANDSCAPED AREAS AND IRRIGATION LINES AS SHOWN ON THE TCP LAYOUTS, TYPICAL SECTIONS AND CONSTRUCTION PLANS.

-OMIT BULB OUT LOCATED FROM STA 36+50 TO STA 40+15. PLACE TEMPORARY PAVEMENT TO MATCH PARKING AREA.

UTILIZING A SINGLE LANE CLOSURE, PRUNE EXISTING TREE LIMBS THAT HANG OVER THE PAVEMENT LOWER THAN 13 FT FROM STA 44+80 TO STA 46+80, AND CONSTRUCT TEMPORARY PAVEMENT SECTION FROM STA 44+80 TO STA 45+75 AS SHOWN IN THE TCP LAYOUTS.

CONSTRUCT THE WATER SERVICE LATERALS FROM STA 52+50 TO STA 53+80 UTILIZING NIGHT/WEEKEND WORK, CUT & RESTORE PAVEMENT, UTILIZE SINGLE LANE CLOSURES AS NEEDED TO CROSS DOLOROSA.

PRELIMINARY
FOR INTERIM REVIEW ONLY
By: MICHAEL G. RAMIREZ P.E. 133983
DATE 1/23/2023
CAMACHO-HERNANDEZ & ASSOCIATES, LLC
NOT FOR CONSTRUCTION, BIDDING, OR PERMIT PURPOSES

REV. NO.	DATE	DESCRIPTION	BY
CAMACHO-HERNANDEZ & ASSOCIATES, LLC 415 EMBASSY OAKS - SUITE 205 SAN ANTONIO, TX. 78216 OFFICE: (210) 341-6200 FAX: (210) 341-6300 FIRM NUMBER: F-8478			

PAPE-DAWSON ENGINEERS
SAN ANTONIO | AUSTIN | HOUSTON | FORT WORTH | DALLAS
2000 NW LOOP 410 | SAN ANTONIO, TX 78213 | 210.375.9000
TEXAS ENGINEERING FIRM #470 | TEXAS SURVEYING FIRM #10028800

CITY OF SAN ANTONIO
PUBLIC WORKS DEPARTMENT

DOLOROSA
SEQUENCE OF WORK NARRATIVE

SHEET 1 OF 2

DESIGN	CHECKED	DRAWN	PROJECT NO.	SUBMITTAL	SHEET NO.
MGR	JH	HR	23-03763	70%	35

Plotted on: 1/23/2023

Design File name: K:\COSA Dolorosa\TCP\Dolorosa_TCP_SEQ_WORk.dgn

SEQUENCE OF WORK NARRATIVE (CONT.)

PHASE 1 - STEP 3 (STA 43+00 TO STA 53+80)

INSTALL APPROPRIATE TRAFFIC CONTROL DEVICES AND SIGNING AS SHOWN ON THE ADVANCED WARNING SIGN LAYOUT, TCP LAYOUTS AND TYPICAL SECTIONS.

DOLOROSA THROUGH TRAFFIC WILL CONSIST OF A SINGLE LANE OF TRAFFIC ALONG THE NORTHERN MOST LANE WITH A SINGLE RIGHT TURN/BUS LOADING LANE.

-MAINTAIN PHASE 1 STEP 2 BARRICADES AND TCP APPURTENANCES FROM THE BEGINNING OF THE PROJECT UP TO STATION 37+50.

-PHASE 1 STEP 2 BARRIER TO BE REMOVED FROM STA 37+50 TO STA 38+25 TO ALLOW FOR A DIVORCED RIGHT TURN MOVEMENT AT THE SANTA ROSA INTERSECTION. SEE TCP LAYOUTS FOR ADDITIONAL INFORMATION.

-PAVEMENT MARKINGS TO BE ELIMINATED FROM STA 43+50 TO STA 53+80 AS SHOWN IN TCP LAYOUTS. (NSPI)

-VIA TO OPEN PROPOSED BUS STOP 87823 (STA 38+90) AND CLOSE TEMPORARY BUS STOP LOCATED AT EXISTING BUS STOP 88913. VIA BUS WILL UTILIZE RIGHT TURN LANE FOR LOADING/UNLOADING. A BUS QUEUE JUMP WILL BE ADDED TO THE TRAFFIC SIGNAL TO ALLOW FOR BUSES TO CROSS THROUGH SANTA ROSA INTERSECTION AND PROCEED THROUGH CONSTRUCTION ZONE.

-VIA TO CLOSE EXISTING BUS STOP 88913 (STA 44+50) AND OPEN A TEMPORARY BUS STOP LOCATED AT THE EXISTING BUS STOP 87823 (STA 38+90.) BUS STOP 87823 WILL REMAIN OPEN AND ALSO SERVICE RIDERSHIP FOR 88913 THROUGHOUT THIS STEP.

-VIA TO CLOSE EXISTING BUS STOP 88973 (STA 53+80) AND OPEN A TEMPORARY BUS STOP LOCATED AT THE EXISTING BUS STOP ACROSS FLORES AT STA 56+70. BUS STOP ACROSS REMAIN OPEN AND ALSO SERVICE RIDERSHIP FOR 88973 THROUGHOUT THIS STEP.

-PERIMETER CONSTRUCTION FENCING WILL BE RELOCATED TO CURB LINE FROM STA 32+20 TO STA 42+00 TO ALLOW FOR PEDESTRIANS TO UTILIZE PREVIOUSLY CONSTRUCTED SIDEWALK ON SOUTHERN (RIGHT) SIDE.

-EXISTING PEDESTRIAN CROSSING BUENA VISTA AT S. LEONA WILL REMAIN CLOSED AND DETOURED TO CROSS AT EITHER FRIO OR S PECOS-LA TRINIDAD.

-EXISTING PEDESTRIAN CROSSING DOLOROSA AT MIDBLOCK WILL REMAIN CLOSED AND DETOURED TO CROSS AT EITHER SAN SABA OR SANTA ROSA.

-SIDEWALK ALONG SOUTHERN (RIGHT) SIDE WILL BE CLOSED FROM STA 43+50 TO STA 50+00. PEDESTRIANS WILL BE DETOURED TO THE NORTH SIDE SIDEWALK WITH PEDESTRIAN CROSSINGS AT SAN SABA AND SANTA ROSA.

-SIDEWALK ALONG SOUTHERN (RIGHT) SIDE WILL REMAIN OPEN FROM STA 50+00 TO STA 53+50 WHILE ROADWAY IS BEING CONSTRUCTED TO ALLOW ACCESS TO THE NEW UTSA COMPLEX. ONCE ROADWAY IS COMPLETED, PEDESTRIANS TO BE DETOURED ONTO THE RECENTLY CONSTRUCTED PAVEMENT VIA TEMPORARY RAMPING WHILE THE SIDEWALK IS BEING CONSTRUCTED. ACCESS TO UTSA COMPLEX AS WELL AS ANY BUSINESSES SHALL BE ALLOWED AT ALL TIMES DURING CONSTRUCTION.

CONSTRUCT THE WATER MAIN FROM STA 43+73 TO STA 45+82 DURING NORMAL CONSTRUCTION HOURS. THIS TO INCLUDE INSTALLING WATER LINE LATERAL AT STA 45+17 TO THE WORK ZONE LIMITS. A TEMPORARY JUMPER CONNECTION WILL BE INSTALLED TO TIE THE NEW LATERAL LINE INTO THE EXISTING LATERAL LINE (STA 45+33.) BRING THIS SECTION OF THE WATER LINE ONLINE.

CONSTRUCT THE SOUTH (RIGHT) SIDE OF DOLOROSA FROM STA 43+80 TO STA 53+50, INCLUDING PROPOSED STORM SEWER, CPS GAS REALIGNMENT, SANITARY SEWER REPLACEMENT, MANHOLE ADJUSTMENTS, CURB, SIDEWALK, DRIVEWAYS, CONCRETE PAVEMENT SECTION, LANDSCAPED AREAS AND IRRIGATION LINES AS SHOWN ON THE TCP LAYOUTS, TYPICAL SECTIONS AND CONSTRUCTION PLANS.

-OMIT BULB OUT LOCATED FROM STA 47+20 TO STA 47+60. PLACE TEMPORARY PAVEMENT TO MATCH PARKING AREA.

BEFORE PHASE/STEP COMPLETION, CONTRACTOR TO CLOSE OUTSIDE LANE ALONG FLORES AS SHOWN IN THE INTERSECTION CLOSURE SHEET TO ALLOW FOR ACCELERATED CONSTRUCTION OF SOUTHWEST CORNER OF DOLOROSA AND FLORES. A SINGLE PEDESTRIAN RAMP WILL NEED TO REMAIN OPEN AT ALL TIMES DURING THIS OPERATION TO ALLOW FOR PEDESTRIANS TO TRAVERSE THROUGH THE INTERSECTION.

PHASE 2 (STA 25+14 TO STA 53+80)

INSTALL APPROPRIATE TRAFFIC CONTROL DEVICES AND SIGNING AS SHOWN ON THE ADVANCED WARNING SIGN LAYOUT, TCP LAYOUTS AND TYPICAL SECTIONS.

DOLOROSA THROUGH TRAFFIC WILL CONSIST OF A SINGLE LANE OF TRAFFIC ALONG THE SOUTHERN MOST LANE WITH BUS LOADING/UNLOADING TURN OUT AREAS.

-BUENA VISTA TRAFFIC ENTERING THE PROJECT WILL BE REDUCED TO A SINGLE LANE OF TRAFFIC (SOUTHERN MOST LANE.)

-LEONA AND S. LAREDO CROSS STREETS SHALL BE CLOSED TO THRU TRAFFIC. PEDESTRIANS AND VEHICLES SHALL BE DETOURED AROUND TO ACCESS DOLOROSA. (SEE TCP DETOUR LAYOUTS.)

PHASE 2 (STA 25+14 TO STA 53+80) (CONT.)

-THRU TRAFFIC WILL BE SHIFTED LEFT AT S PECOS-LA TRINIDAD TO ALLOW FOR BUS PULL OUT AREA TO BE PLACED AT EXISTING BUS STOP. AFTER BUS LOADING/UNLOADING, BUS TO MERGE LEFT PRIOR TO CROSSING S PECOS-LA TRINIDAD.

-TRAFFIC APPROACHING S FLORES INTERSECTION WILL BE CONVERTED TO TWO LANES (THRU/LT & BUS/RT) TO ALLOW FOR BUS LOADING/UNLOADING AT PROPOSED BUS STOP. BUS WILL BE ALLOWED ACCESS TO BUS ONLY LANE THRU INTERSECTION.

-PROPOSED VIA BUS STOP 86883 SHALL REMAIN OPEN AND FUNCTION AS NORMAL.

-VIA TO CLOSE PROPOSED BUS STOP 87823 (STA 39+00) AND OPEN A TEMPORARY BUS STOP LOCATED AT STA 40+00 FOR THIS STOP TO BE RELOCATED TO FOR PHASE 2.

-VIA TO CLOSE PROPOSED BUS STOP 88913 (STA 44+05) AND OPEN A TEMPORARY BUS STOP LOCATED AT STA 47+80 FOR THIS STOP TO BE RELOCATED TO FOR PHASE 2.

-PROPOSED VIA BUS STOP 88973 SHALL REMAIN OPEN AND FUNCTION AS NORMAL.

-PROPOSED PEDESTRIAN CROSSINGS AT S. LEONA AND THE MIDBLOCK CROSSING WILL REMAIN CLOSED AND BE DETOURED TO ADJACENT CROSSINGS.

-SIDEWALK ALONG NORTHERN (LEFT) SIDE WILL BE CLOSED TO PEDESTRIAN TRAFFIC FROM STA 25+20 TO STA 53+50. PEDESTRIANS WILL BE DETOURED AROUND CONSTRUCTION AREA TO CROSS DOLOROSA AT FRIO, IH-10 FRONTAGE ROAD, SAN SABA, SANTA ROSA AND FLORES TO UTILIZE THE SOUTHERN (RIGHT) RECENTLY CONSTRUCTED SIDEWALK.

-SIDEWALKS TO REMAIN FUNCTIONAL AND ACCESSABLE TO PEDESTRIANS UTILIZING CONSTRUCTION FENCING ALONG CURB LINE WHENEVER CONSTRUCTION IS NOT BEING DONE WITHIN THE AREA. LOCAL BUSINESSES TO HAVE ACCESS AT ALL TIMES DURING CONSTRUCTION.

CONSTRUCT ALL REMAINING WATER LINES THAT CROSS FROM PREVIOUS PHASES. TEMPORARY JUMPERS TO BE REMOVED AND FINAL WATER ALIGNMENTS TO BE COMPLETED.

CONSTRUCT THE REMAINING PORTION OF THE PROPOSED CONDUITS. TO CONSTRUCT PROPOSED CONDUIT LINE ACROSS SAN SABA UTILIZE A PAIR OF BORE PITS LOCATED WITHIN THE WORK ZONE TO AVOID HAVING TO OPEN TRENCH THROUGH THE RECENTLY CONSTRUCTED (SEPARATE PROJECT) PAVEMENT OF SAN SABA.

CONSTRUCT THE NORTH (LEFT) SIDE OF DOLOROSA FROM STA 25+14 TO STA 53+80, INCLUDING PROPOSED STORM SEWER, CPS GAS REALIGNMENT, SANITARY SEWER REPLACEMENT, MANHOLE ADJUSTMENTS, CURB, SIDEWALK, DRIVEWAYS, CONCRETE PAVEMENT SECTION, LANDSCAPED AREAS AND IRRIGATION LINES AS SHOWN ON THE TCP LAYOUTS AND TYPICAL SECTIONS AND AS PER THE CONSTRUCTION PLANS.

BEFORE PHASE/STEP COMPLETION, CONTRACTOR TO CLOSE OUTSIDE LANE ALONG FRIO TO ALLOW FOR ACCELERATED CONSTRUCTION OF NORTHEAST CORNER OF BUENA VISTA AND FRIO. AS WELL AS, CLOSE OUTSIDE LANE ALONG FLORES TO ALLOW FOR ACCELERATED CONSTRUCTION OF NORTHWEST CORNER OF DOLOROSA AND FLORES. A SINGLE RAMP TO MAINTAIN FUNCTIONAL AT ALL TIMES DURING THIS CONSTRUCTION TO ALLOW FOR PEDESTRIANS TO BE DETOURED AROUND THE INTERSECTION AS NEEDED.

INTERSECTION CONSTRUCTION AT DOLOROSA AND S PECOS-LA TRINIDAD SHALL BE COMPLETED WITH ACCELERATED CONSTRUCTION IN STEPS WITH HALF ROADWAY CLOSURES OF S PECOS-LA TRINIDAD. AS SHOWN ON THE TCP INTERSECTION CLOSURE LAYOUT AND AS PER THE CONSTRUCTION PLANS. CONSTRUCTION TO INCLUDE CPS DUCT BANK, CURB, SIDEWALK AND CONCRETE PAVEMENT SECTION. INTERSECTION CONSTRUCTION TO DETOUR PEDESTRIANS AROUND CONSTRUCTION VIA A DETOUR ROUTE UP TO UTILIZE COMMERCE TO THE NORTH. ONCE THE INTERSECTION HAS BEEN COMPLETED, THE NEXT PHASE/STEP CAN BE STARTED.

PHASE 3 (STA 36+50 TO STA 47+60)

ALL LANE CLOSURES SHALL BE IN ACCORDANCE WITH THE TEXAS MANUAL ON UNIFORM TRAFFIC CONTROL DEVICES (TMUTCD), CITY OF SAN ANTONIO STANDARDS AND/OR AS DIRECTED BY THE ENGINEER.

COMPLETE THE PLACEMENT OF PERMANENT PAVEMENT MARKINGS UTILIZING MOBILE, SHORT TERM OR INTERMEDIATE TERM CONSTRUCTION OPERATIONS AS NEEDED.

UTILIZING A SINGLE LANE CLOSURE, CLOSE THE OUTSIDE LANE TO CONSTRUCT THE OMITTED BULB OUTS, LANDSCAPED AREAS AND IRRIGATION LINES LOCATED AT STA 36+50 TO STA 40+15 AND STA 47+20 TO STA 47+60.

COMPLETE PROPOSED SIGNING AND BRING ALL PERMANENT TRAFFIC SIGNALS INTO OPERATION.

PERFORM FINAL PROJECT CLEANUP AND OPEN LANES TO TRAFFIC.

Revise if needed. San Saba Intersection paving to be added to this project.

Revise this note for clarity

PRELIMINARY
FOR INTERIM REVIEW ONLY

By: MICHAEL G. RAMIREZ P.E. 133983
DATE 1/23/2023

CAMACHO-HERNANDEZ & ASSOCIATES, LLC
NOT FOR CONSTRUCTION, BIDDING, OR PERMIT PURPOSES

REV. NO. DATE DESCRIPTION BY

CAMACHO-HERNANDEZ & ASSOCIATES, LLC
415 EMBASSY OAKS - SUITE 205 SAN ANTONIO, TX. 78216
OFFICE: (210) 341-6200 FAX: (210) 341-6300
FIRM NUMBER: F-8478

PAPE-DAWSON ENGINEERS

SAN ANTONIO | AUSTIN | HOUSTON | FORT WORTH | DALLAS
2000 NW LOOP 410 | SAN ANTONIO, TX 78213 | 210.375.9000
TEXAS ENGINEERING FIRM #470 | TEXAS SURVEYING FIRM #10028800

CITY OF SAN ANTONIO
PUBLIC WORKS DEPARTMENT

DOLOROSA
SEQUENCE OF WORK NARRATIVE

DESIGN	CHECKED	DRAWN	PROJECT NO.	SUBMITTAL	SHEET NO.
MGR	JH	HR	23-03763	70%	36

Plotted on: 1/23/2023

Design File name: K:\COSA Dolorosa\TCP\Dolorosa_TCP_SEQ_WORK.dgn

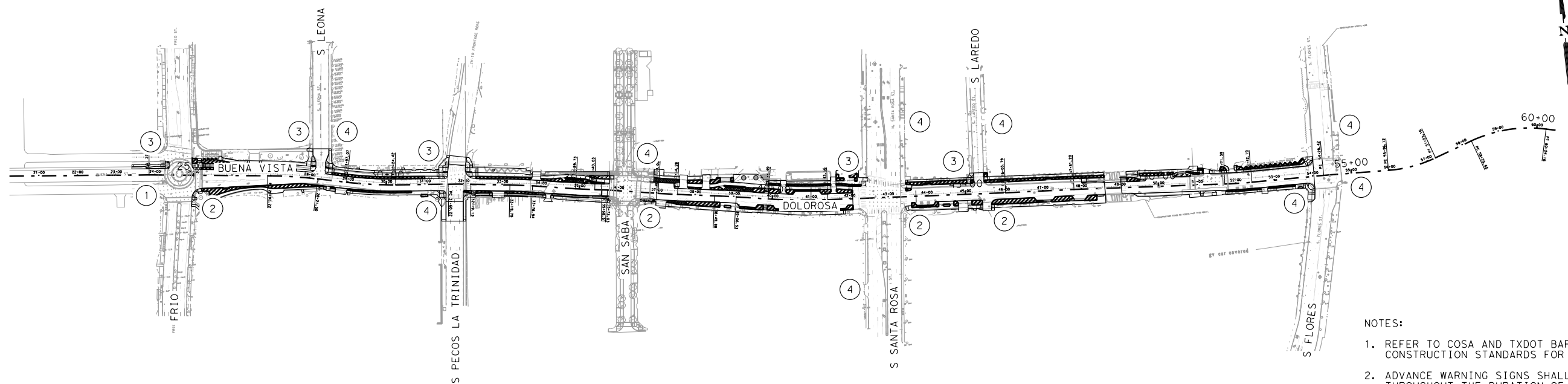

- NOTES:
1. REFER TO COSA AND TXDOT BARRICADE AND CONSTRUCTION STANDARDS FOR MORE INFORMATION.
 2. ADVANCE WARNING SIGNS SHALL REMAIN IN PLACE THROUGHOUT THE DURATION OF THE PROJECT.

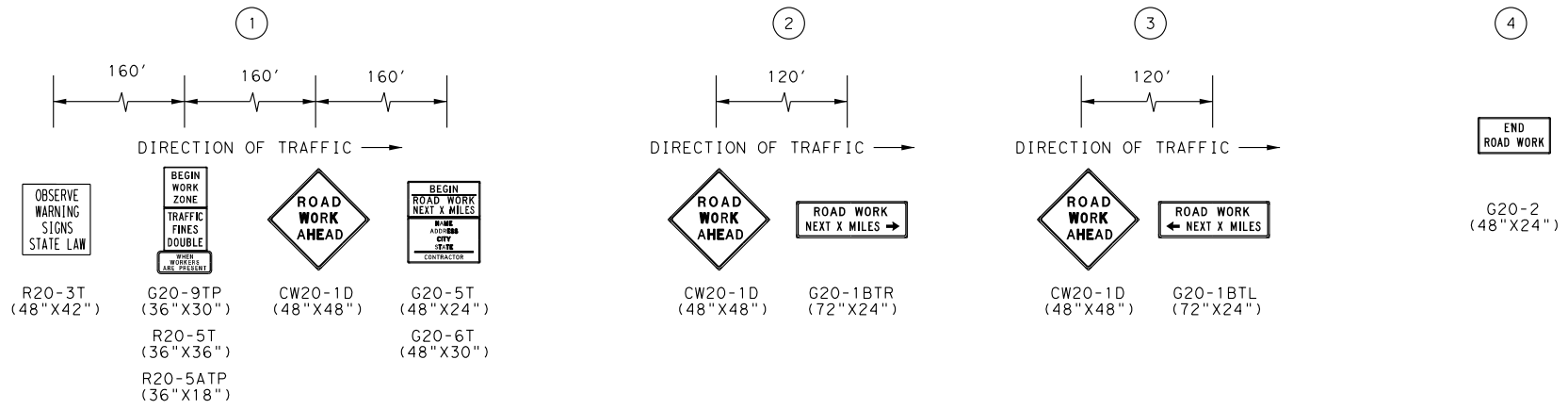

PRELIMINARY
 FOR INTERIM REVIEW ONLY
 By: MICHAEL G. RAMIREZ P.E. 133983
 DATE 1/23/2023
CAMACHO-HERNANDEZ & ASSOCIATES, LLC
 NOT FOR CONSTRUCTION, BIDDING, OR PERMIT PURPOSES

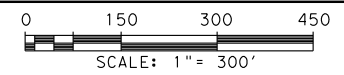

REV. NO.	DATE	DESCRIPTION	BY

CAMACHO-HERNANDEZ & ASSOCIATES, LLC
 415 EMBASSY OAKS - SUITE 205 SAN ANTONIO, TX. 78216
 OFFICE: (210) 341-6200 FAX: (210) 341-6300
 FIRM NUMBER: F-8478

PAPE-DAWSON ENGINEERS
 SAN ANTONIO | AUSTIN | HOUSTON | FORT WORTH | DALLAS
 2000 NW LOOP 410 | SAN ANTONIO, TX 78213 | 210.375.9000
 TEXAS ENGINEERING FIRM #470 | TEXAS SURVEYING FIRM #10028800

CITY OF SAN ANTONIO PUBLIC WORKS DEPARTMENT

DOLOROSA
 ADVANCE WARNING SIGN LAYOUT

DESIGN	CHECKED	DRAWN	PROJECT NO.	SUBMITTAL	SHEET NO.
MGR	JH	HR	23-03763	70%	37

SHEET 1 OF 1

Plotted on: 1/23/2023

Design File name: K:\COSA Dolorosa\TCP\Dolorosa_TCP_PHASE_LAYOUT.dgn

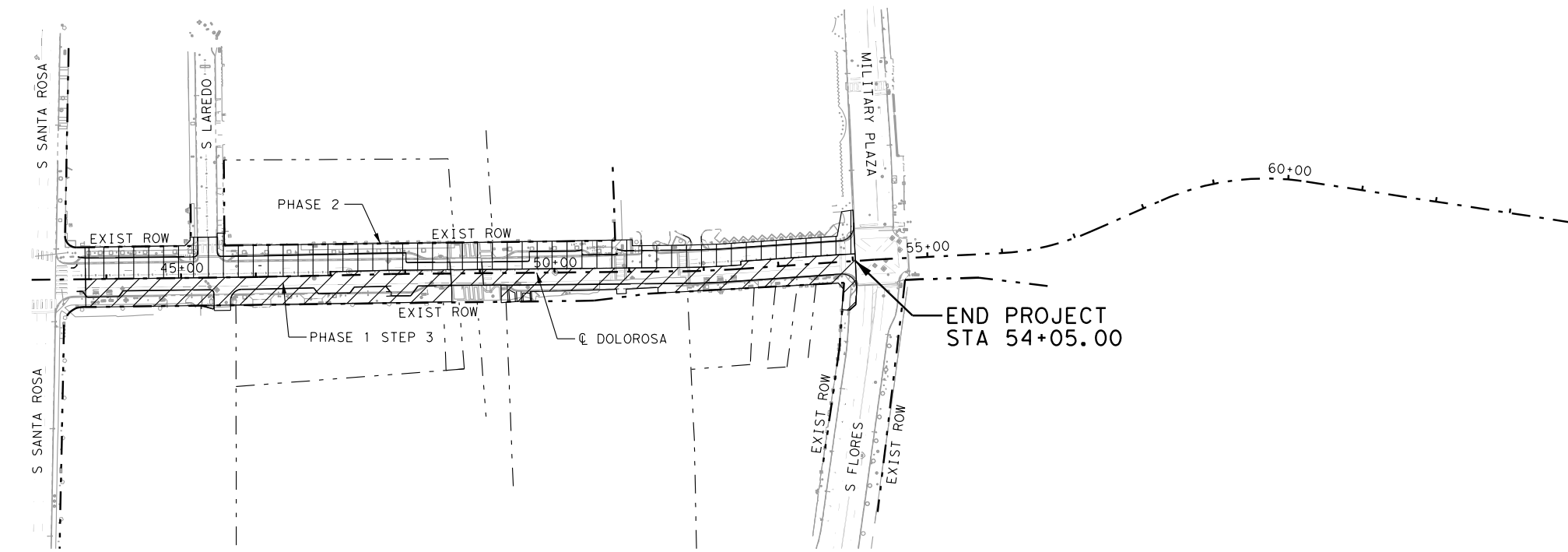
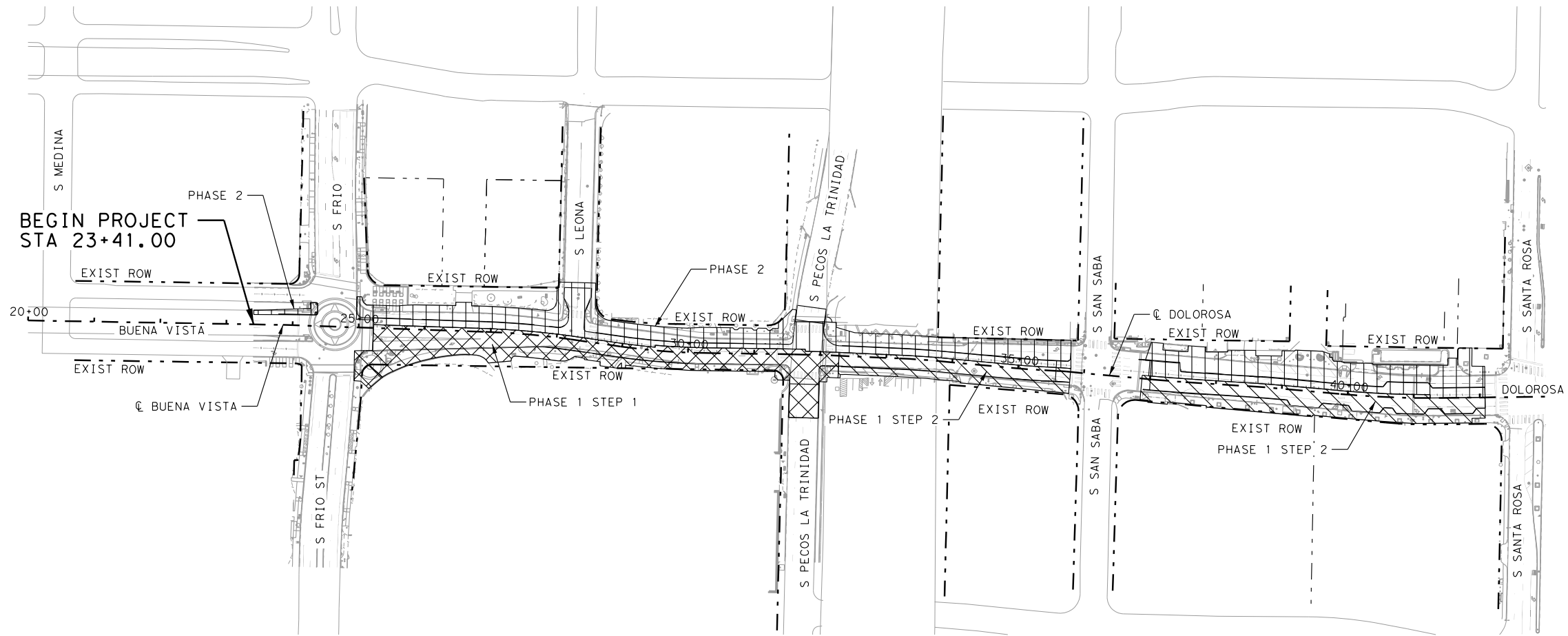

LEGEND

- EXISTING ROW
- EXISTING ROADWAY
- PROPOSED ROADWAY
- PHASE 1 STEP 1
- PHASE 1 STEP 2
- PHASE 1 STEP 3
- PHASE 2

PRELIMINARY
FOR INTERIM REVIEW ONLY

By: MICHAEL G. RAMIREZ P.E. 133983
DATE 1/23/2023

CAMACHO-HERNANDEZ & ASSOCIATES, LLC
NOT FOR CONSTRUCTION, BIDDING, OR PERMIT PURPOSES

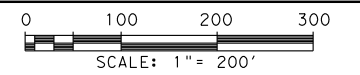

REV. NO.	DATE	DESCRIPTION	BY
CAMACHO-HERNANDEZ & ASSOCIATES, LLC 415 EMBASSY OAKS - SUITE 205 SAN ANTONIO, TX. 78216 OFFICE: (210) 341-6200 FAX: (210) 341-6300 FIRM NUMBER: F-8478			

Pape-Dawson ENGINEERS

SAN ANTONIO | AUSTIN | HOUSTON | FORT WORTH | DALLAS
2000 NW LOOP 410 | SAN ANTONIO, TX 78213 | 210.375.9000
TEXAS ENGINEERING FIRM #470 | TEXAS SURVEYING FIRM #10028800

CITY OF SAN ANTONIO
PUBLIC WORKS DEPARTMENT

DOLOROSA
TRAFFIC CONTROL PLAN
PHASING LAYOUT

SHEET 1 OF 1

DESIGN	CHECKED	DRAWN	PROJECT NO.	SUBMITTAL	SHEET NO.
MGR	JH	HR	23-03763	70%	38

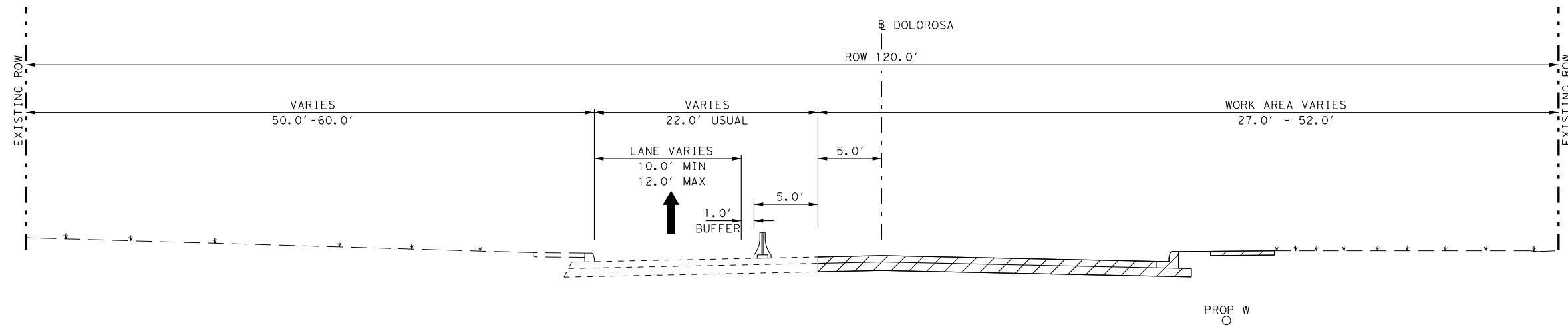

PHASE 1 STEP 1

STA 25+16.00 TO STA 28+00.00

LEGEND

- EXISTING ROADWAY
- PROPOSED ROADWAY
- WORK AREA
- ACCELERATED WORK AREA
- TEMPORARY PAVEMENT
- LOW PROFILE WATER FILL BARRIER
- VERTICAL PANELS

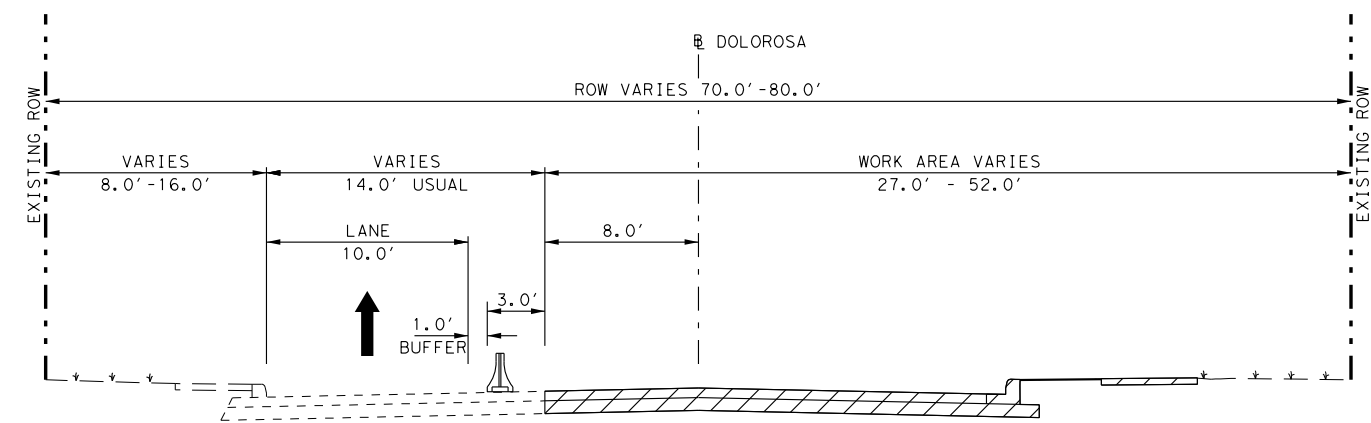

PHASE 1 STEP 1

STA 28+00.00 TO STA 31+32.50

PRELIMINARY
FOR INTERIM REVIEW ONLY

By: MICHAEL G. RAMIREZ P.E. 133983
DATE 1/23/2023

CAMACHO-HERNANDEZ & ASSOCIATES, LLC
NOT FOR CONSTRUCTION, BIDDING, OR PERMIT PURPOSES

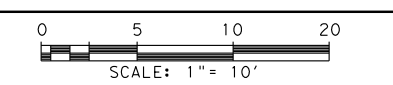

REV. NO.	DATE	DESCRIPTION	BY

CAMACHO-HERNANDEZ & ASSOCIATES, LLC
415 EMBASSY OAKS - SUITE 205 SAN ANTONIO, TX. 78216
OFFICE: (210) 341-6200 FAX: (210) 341-6300
FIRM NUMBER: F-8478

PAPE-DAWSON ENGINEERS

SAN ANTONIO | AUSTIN | HOUSTON | FORT WORTH | DALLAS
2000 NW LOOP 410 | SAN ANTONIO, TX 78213 | 210.375.9000
TEXAS ENGINEERING FIRM #470 | TEXAS SURVEYING FIRM #10028800

CITY OF SAN ANTONIO PUBLIC WORKS DEPARTMENT

DOLOROSA
TRAFFIC CONTROL PLAN
TYPICAL SECTIONS

PHASE 1 STEP 1

SHEET 1 OF 1

DESIGN	CHECKED	DRAWN	PROJECT NO.	SUBMITTAL	SHEET NO.
MGR	JH	HR	23-03763	70%	39

Plotted on: 1/23/2023

Design File name: K:\COSA Dolorosa\TCP\Dolorosa_TCP_DETOUR01.dgn

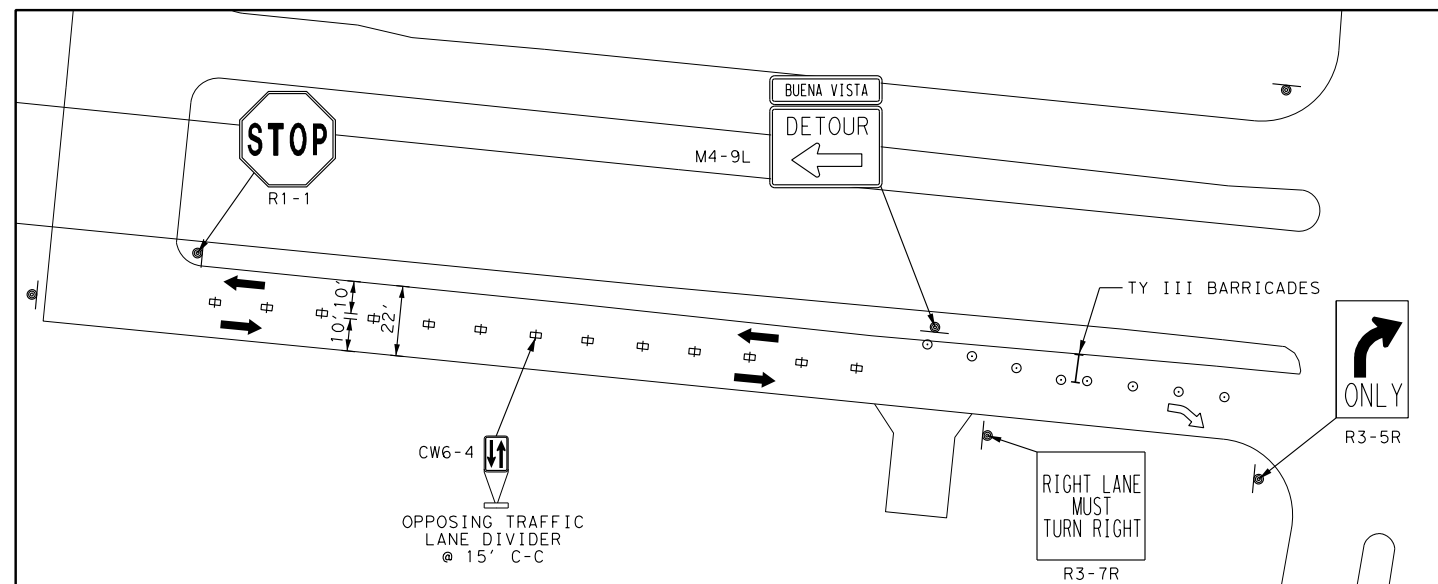
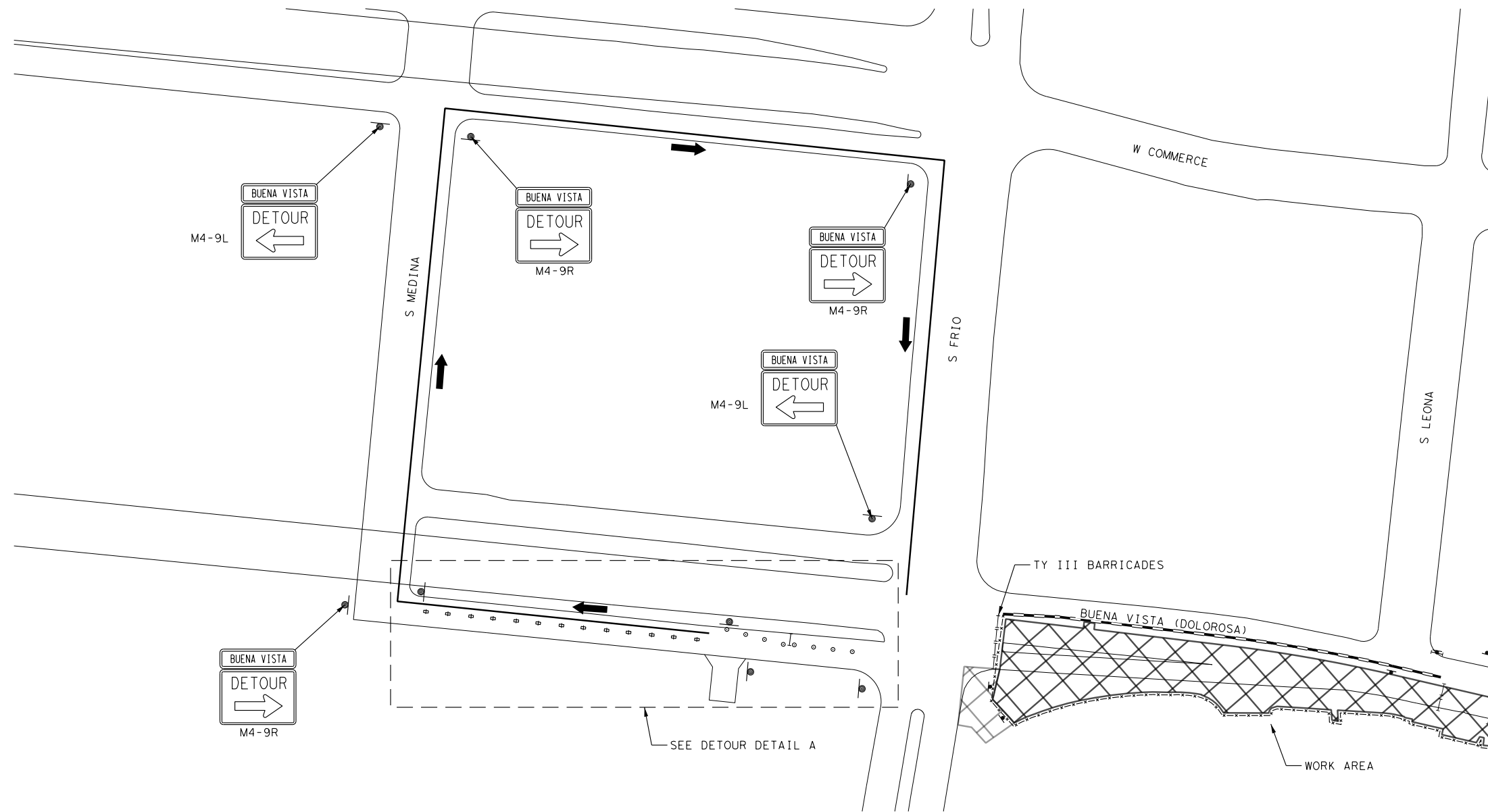

DETOUR DETAIL A
SCALE: 1"=60'

PRELIMINARY
FOR INTERIM REVIEW ONLY

By: MICHAEL G. RAMIREZ P.E. 133983
DATE 1/23/2023

CAMACHO-HERNANDEZ & ASSOCIATES, LLC
NOT FOR CONSTRUCTION, BIDDING, OR PERMIT PURPOSES

0 50 100 150
SCALE: 1" = 100'

REV. NO.	DATE	DESCRIPTION	BY

CAMACHO-HERNANDEZ & ASSOCIATES, LLC
415 EMBASSY OAKS - SUITE 205 SAN ANTONIO, TX. 78216
OFFICE: (210) 341-6200 FAX: (210) 341-6300
FIRM NUMBER: F-8478

PAPE-DAWSON ENGINEERS
SAN ANTONIO | AUSTIN | HOUSTON | FORT WORTH | DALLAS
2000 NW LOOP 410 | SAN ANTONIO, TX 78213 | 210.375.9000
TEXAS ENGINEERING FIRM #470 | TEXAS SURVEYING FIRM #10028800

CITY OF SAN ANTONIO
PUBLIC WORKS DEPARTMENT
DOLOROSA
**TRAFFIC CONTROL PLAN
DETOUR LAYOUT**
PHASE 1 - S MEDINA

DESIGN	CHECKED	DRAWN	PROJECT NO.	SUBMITTAL	SHEET NO.
MGR	JH	HR	23-03763	70%	40

Plotted on: 1/23/2023

Design File name: K:\COSA Dolorosa\TCP\Dolorosa_TCP_P1S1_01.dgn

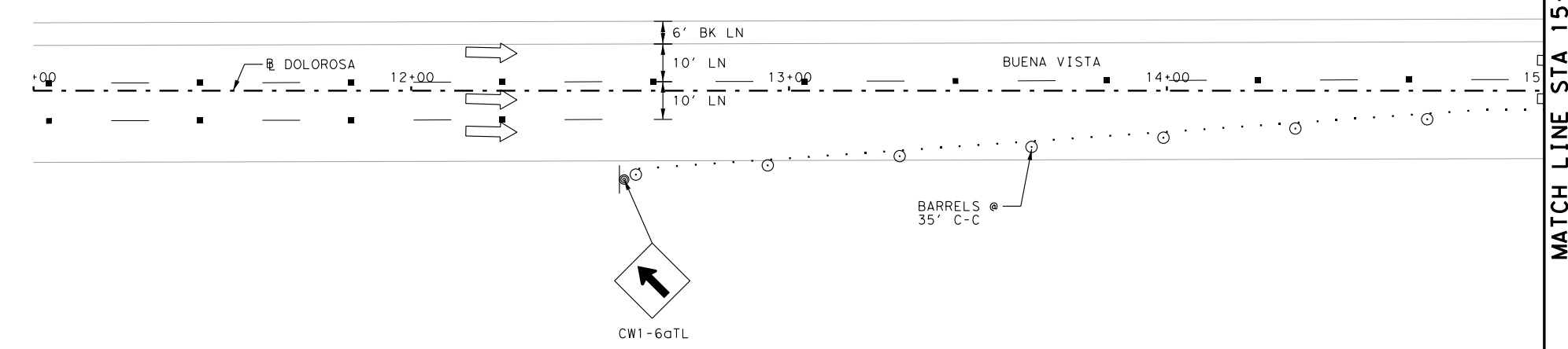
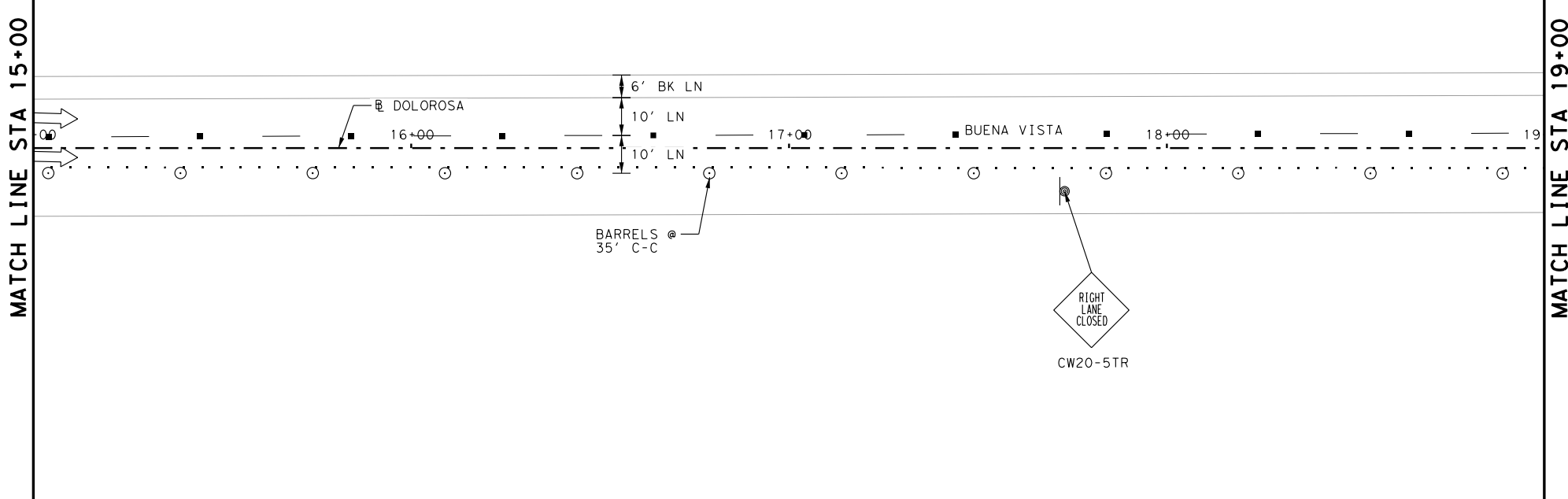

ITEM	DESCRIPTION	UNIT	QTY
540.7	CONSTRUCTION PERIMETER FENCE	LF	-
5000	WATER FILLED BARRIER	LF	-
0508-6001	CONSTRUCTING DETOURS	SY	-
0662-6063	WK ZN PAV MRK REMOV (W)4" (SLD)	LF	643
0662-6071	WK ZN PAV MRK REMOV (W)8" (SLD)	LF	-
0662-6075	WK ZN PAV MRK REMOV (W)24" (SLD)	LF	-
0667-6001	ELIM EXT PAV MRK & MRKS (4")	LF	161
0667-6003	ELIM EXT PAV MRK & MRKS (8")	LF	-
0667-6007	ELIM EXT PAV MRK & MRKS (24")	LF	-
0667-6008	ELIM EXT PAV MRK & MRKS (ARROW)	EA	-

LEGEND

- CONSTRUCTION THIS PHASE
- ACCELERATED CONSTRUCTION
- TEMPORARY BUS STOP
- TEMPORARY PAVEMENT
- DIRECTION OF TRAFFIC (TCP/EXIST)
- VERTICAL PANELS
- TYPE III BARRICADE
- CONSTRUCTION PERIMETER FENCE
- LOW PROFILE WATER FILL BARRIER
- SIGN
- PLASTIC DRUMS

NOTES:
 1. CONTRACTOR SHALL PROVIDE DRIVEWAY SIGNAGE AFFIXED TO THE TOP OF PLASTIC DRUMS AT ALL DRIVEWAY LOCATIONS.
 2. VIA IS RESPONSIBLE FOR ALL TEMPORARY BUS STOPS AND RELATED SIGNING. ONCE VIA SETS UP TEMPORARY BUS STOPS CONTRACTOR SHALL ENSURE SIGNAGE REMAINS VISIBLE.
 3. ELIMINATE PAVEMENT MARKINGS FOR CONTRACTOR INFO ONLY (NSPI.)

PRELIMINARY
 FOR INTERIM REVIEW ONLY
 By: MICHAEL G. RAMIREZ P.E. 133983
 DATE 1/23/2023
CAMACHO-HERNANDEZ & ASSOCIATES, LLC
 NOT FOR CONSTRUCTION, BIDDING, OR PERMIT PURPOSES

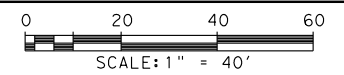

REV. NO.	DATE	DESCRIPTION	BY
CAMACHO-HERNANDEZ & ASSOCIATES, LLC 415 EMBASSY OAKS - SUITE 205 SAN ANTONIO, TX. 78216 OFFICE: (210) 341-6200 FAX: (210) 341-6300 FIRM NUMBER: F-8478			

Pape-Dawson ENGINEERS
 SAN ANTONIO | AUSTIN | HOUSTON | FORT WORTH | DALLAS
 2000 NW LOOP 410 | SAN ANTONIO, TX 78213 | 210.375.9000
 TEXAS ENGINEERING FIRM #470 | TEXAS SURVEYING FIRM #10028800

CITY OF SAN ANTONIO
PUBLIC WORKS DEPARTMENT

DOLOROSA
TRAFFIC CONTROL PLAN
 PHASE 1 STEP 1

BEGIN TO STA 19+00

SHEET 1 OF 3

DESIGN	CHECKED	DRAWN	PROJECT NO.	SUBMITTAL	SHEET NO.
MGR	JH	HR	23-03763	70%	41

Plotted on: 1/23/2023

Design File name: K:\COSA Dolorosa\TCP\Dolorosa_TCP_P1S1_02.dgn

General Comment: Review section 6F.14 for sidewalk and crosswalk closure signage.

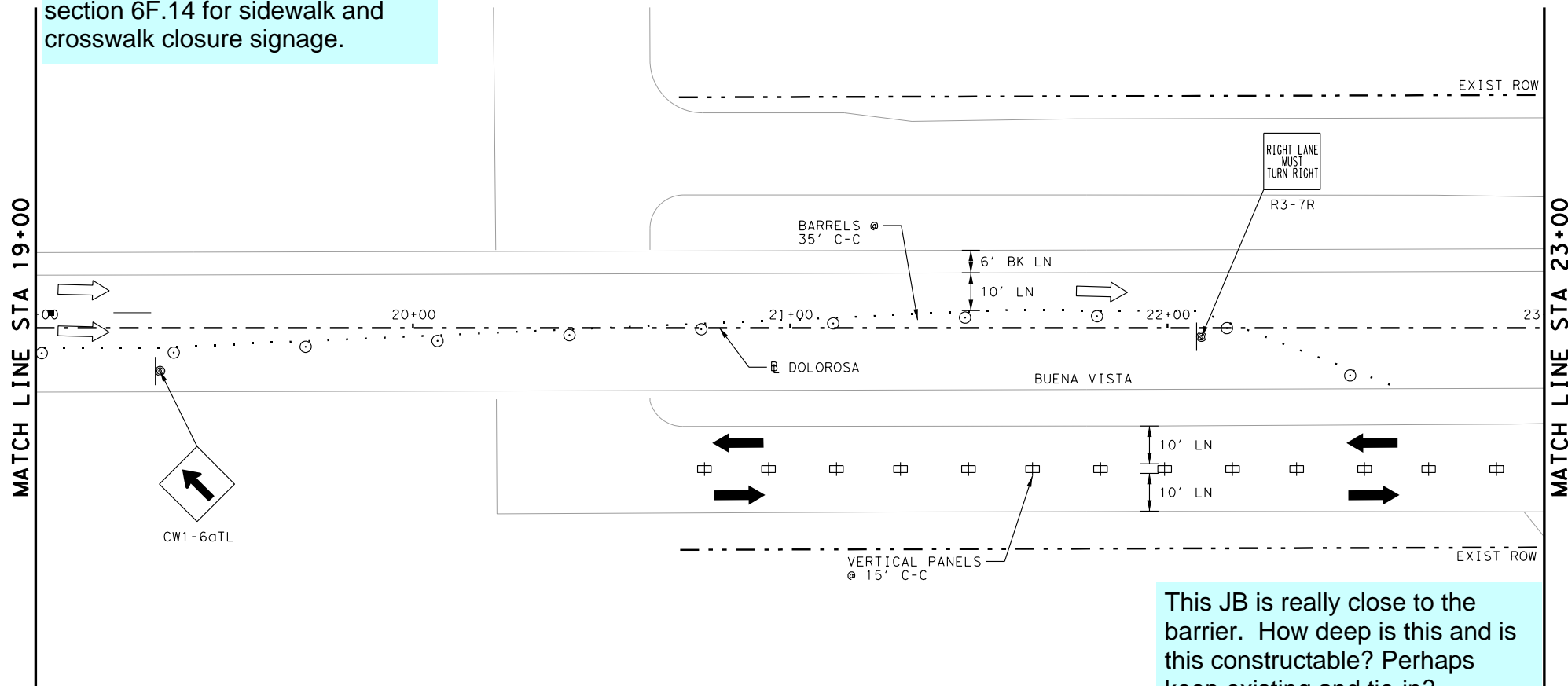

ITEM	DESCRIPTION	UNIT	QTY
540.7	CONSTRUCTION PERIMETER FENCE	LF	71
5000	WATER FILLED BARRIER	LF	180
0508-6001	CONSTRUCTING DETOURS	SY	-
0662-6063	WK ZN PAV MRK REMOV (W)4" (SLD)	LF	763
0662-6071	WK ZN PAV MRK REMOV (W)8" (SLD)	LF	-
0662-6075	WK ZN PAV MRK REMOV (W)24" (SLD)	LF	-
0667-6001	ELIM EXT PAV MRK & MRKS (4")	LF	288
0667-6003	ELIM EXT PAV MRK & MRKS (8")	LF	-
0667-6007	ELIM EXT PAV MRK & MRKS (24")	LF	-
0667-6008	ELIM EXT PAV MRK & MRKS (ARROW)	EA	-

LEGEND

	CONSTRUCTION THIS PHASE
	ACCELERATED CONSTRUCTION
	TEMPORARY BUS STOP
	TEMPORARY PAVEMENT
	DIRECTION OF TRAFFIC (TCP/EXIST)
	VERTICAL PANELS
	TYPE III BARRICADE
	CONSTRUCTION PERIMETER FENCE
	LOW PROFILE WATER FILL BARRIER
	SIGN
	PLASTIC DRUMS

- NOTES:
- CONTRACTOR SHALL PROVIDE DRIVEWAY SIGNAGE AFFIXED TO THE TOP OF PLASTIC DRUMS AT ALL DRIVEWAY LOCATIONS.
 - VIA IS RESPONSIBLE FOR ALL TEMPORARY BUS STOPS AND RELATED SIGNING. ONCE VIA SETS UP TEMPORARY BUS STOPS CONTRACTOR SHALL ENSURE SIGNAGE REMAINS VISIBLE.
 - ELIMINATE PAVEMENT MARKINGS FOR CONTRACTOR INFO ONLY (NSP1.)

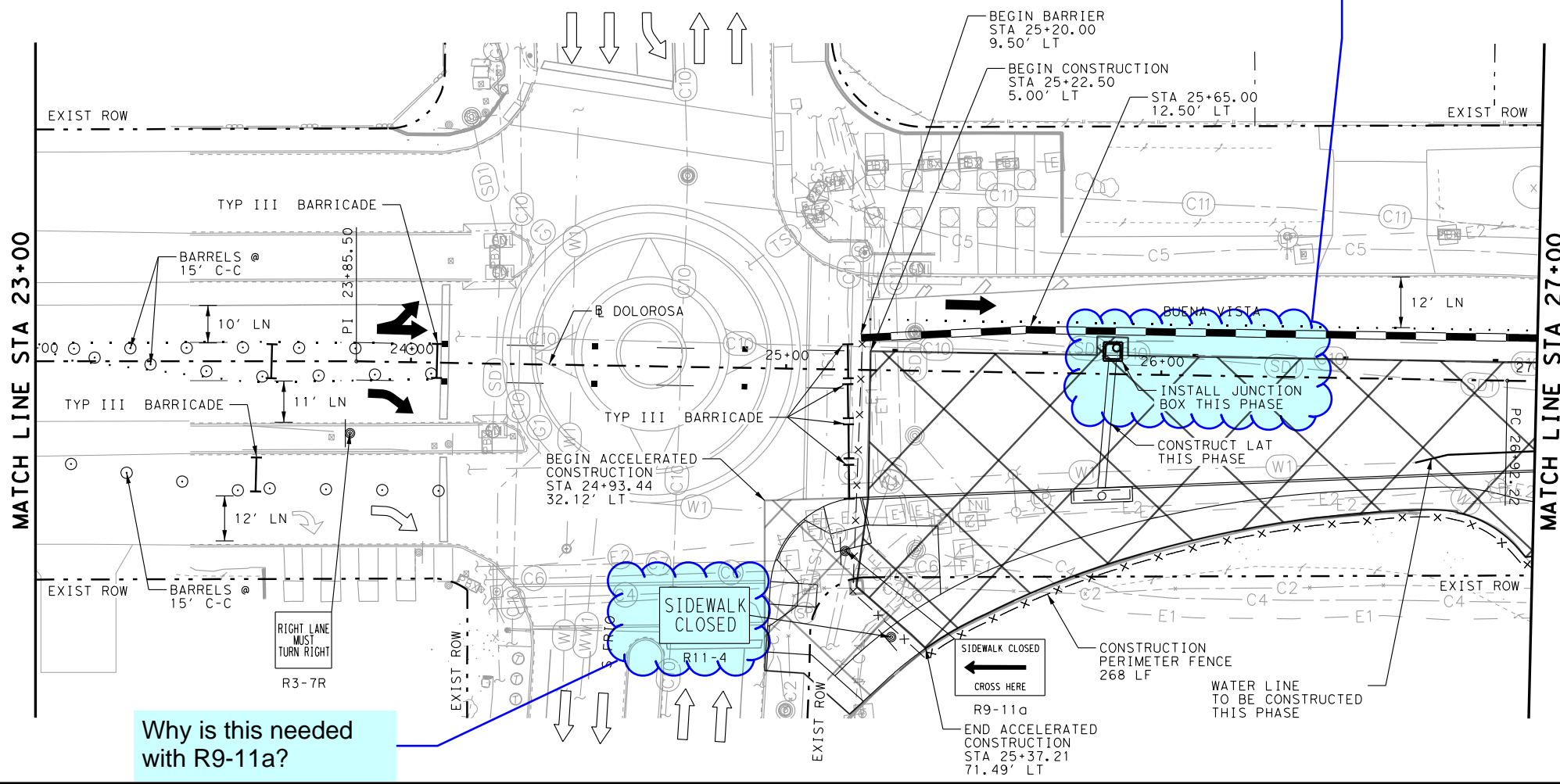

PRELIMINARY
FOR INTERIM REVIEW ONLY
 By: MICHAEL G. RAMIREZ P.E. 133983
 DATE 1/23/2023
CAMACHO-HERNANDEZ & ASSOCIATES, LLC
 NOT FOR CONSTRUCTION, BIDDING, OR PERMIT PURPOSES

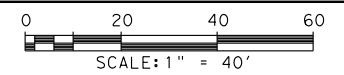

REV. NO.	DATE	DESCRIPTION	BY

CAMACHO-HERNANDEZ & ASSOCIATES, LLC
 415 EMBASSY OAKS - SUITE 205 SAN ANTONIO, TX. 78216
 OFFICE: (210) 341-6200 FAX: (210) 341-6300
 FIRM NUMBER: F-8478

PAPE-DAWSON ENGINEERS
 SAN ANTONIO | AUSTIN | HOUSTON | FORT WORTH | DALLAS
 2000 NW LOOP 410 | SAN ANTONIO, TX 78213 | 210.375.9000
 TEXAS ENGINEERING FIRM #470 | TEXAS SURVEYING FIRM #10028800

CITY OF SAN ANTONIO PUBLIC WORKS DEPARTMENT

DOLOROSA
TRAFFIC CONTROL PLAN
PHASE 1 STEP 1
 STA 19+00 TO STA 27+00

SHEET 2 OF 3

DESIGN	CHECKED	DRAWN	PROJECT NO.	SUBMITTAL	SHEET NO.
MGR	JH	HR	23-03763	70%	42

Plotted on: 1/23/2023

Design File name: K:\COSA Dolores\TCP\Doloresa_TCP_P1S1_03.dgn

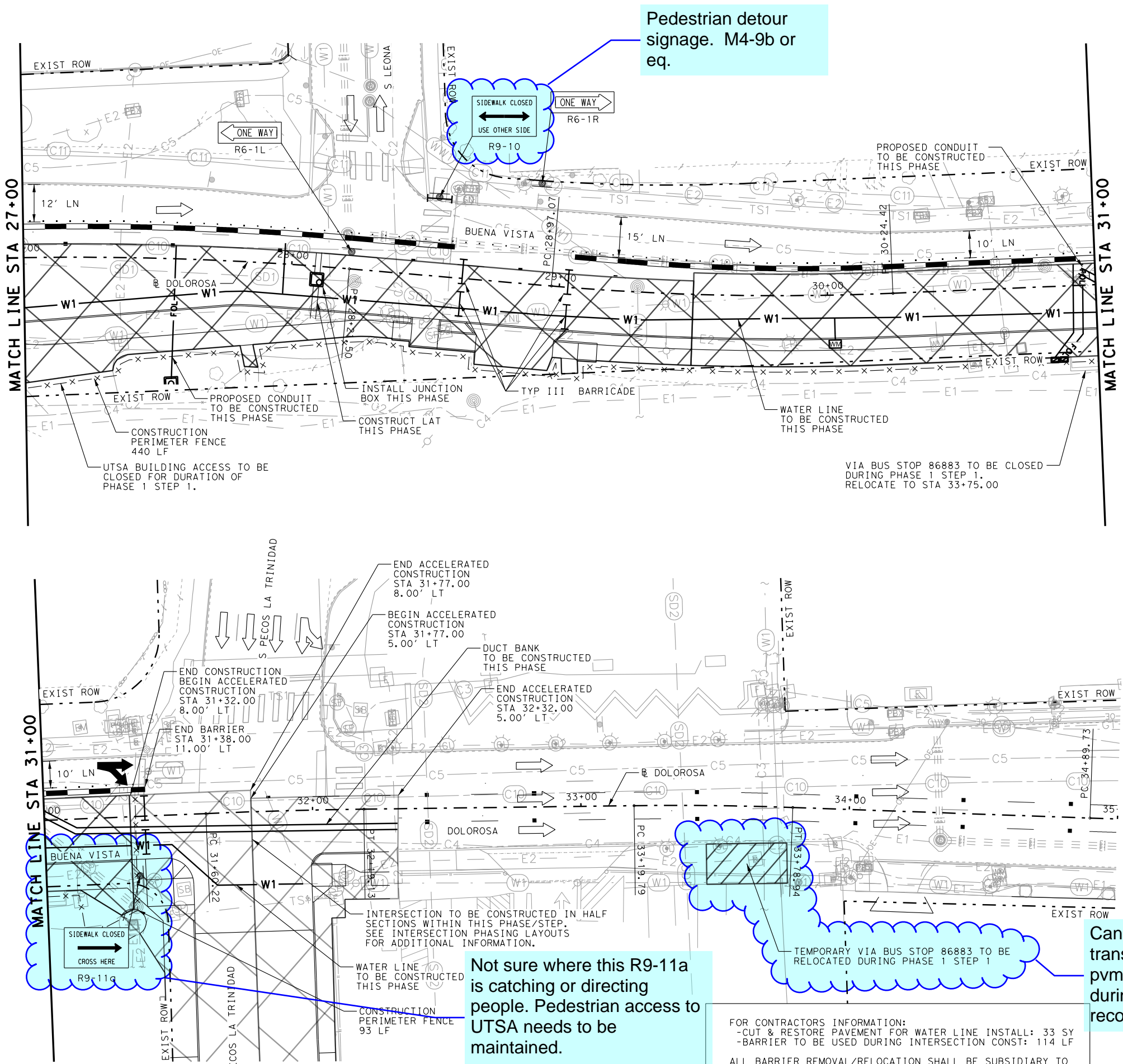

Pedestrian detour signage. M4-9b or eq.

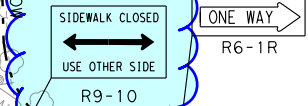

UTSA BUILDING ACCESS TO BE CLOSED FOR DURATION OF PHASE 1 STEP 1.

VIA BUS STOP 86883 TO BE CLOSED DURING PHASE 1 STEP 1. RELOCATE TO STA 33+75.00

Not sure where this R9-11a is catching or directing people. Pedestrian access to UTSA needs to be maintained.

Can bus make transition across pvmt. to this location during intersection reconstruction?

FOR CONTRACTORS INFORMATION:
 -CUT & RESTORE PAVEMENT FOR WATER LINE INSTALL: 33 SY
 -BARRIER TO BE USED DURING INTERSECTION CONST: 114 LF
 ALL BARRIER REMOVAL/RELOCATION SHALL BE SUBSIDIARY TO INSTALLATION COST OF WATER BARRIER. (NSP1)

ITEM	DESCRIPTION	UNIT	QTY
540.7	CONSTRUCTION PERIMETER FENCE	LF	107
5000	WATER FILLED BARRIER	LF	507
0508-6001	CONSTRUCTING DETOURS	SY	-
0662-6063	WK ZN PAV MRK REMOV (W)4" (SLD)	LF	438
0662-6071	WK ZN PAV MRK REMOV (W)8" (SLD)	LF	-
0662-6075	WK ZN PAV MRK REMOV (W)24" (SLD)	LF	-
0667-6001	ELIM EXT PAV MRK & MRKS (4")	LF	67
0667-6003	ELIM EXT PAV MRK & MRKS (8")	LF	-
0667-6007	ELIM EXT PAV MRK & MRKS (24")	LF	-
0667-6008	ELIM EXT PAV MRK & MRKS (ARROW)	EA	-

LEGEND

- CONSTRUCTION THIS PHASE
- ACCELERATED CONSTRUCTION
- TEMPORARY BUS STOP
- TEMPORARY PAVEMENT
- DIRECTION OF TRAFFIC (TCP/EXIST)
- VERTICAL PANELS
- TYPE III BARRICADE
- CONSTRUCTION PERIMETER FENCE
- LOW PROFILE WATER FILL BARRIER
- SIGN
- PLASTIC DRUMS

- NOTES:
- CONTRACTOR SHALL PROVIDE DRIVEWAY SIGNAGE AFFIXED TO THE TOP OF PLASTIC DRUMS AT ALL DRIVEWAY LOCATIONS.
 - VIA IS RESPONSIBLE FOR ALL TEMPORARY BUS STOPS AND RELATED SIGNING. ONCE VIA SETS UP TEMPORARY BUS STOPS CONTRACTOR SHALL ENSURE SIGNAGE REMAINS VISIBLE.
 - ELIMINATE PAVEMENT MARKINGS FOR CONTRACTOR INFO ONLY (NSP1.)

PRELIMINARY
 FOR INTERIM REVIEW ONLY
 By: MICHAEL G. RAMIREZ P.E. 133983
 DATE 1/23/2023
CAMACHO-HERNANDEZ & ASSOCIATES, LLC
 NOT FOR CONSTRUCTION, BIDDING, OR PERMIT PURPOSES

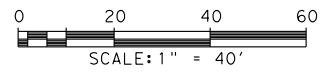

REV. NO.	DATE	DESCRIPTION	BY

CAMACHO-HERNANDEZ & ASSOCIATES, LLC
 415 EMBASSY OAKS - SUITE 205 SAN ANTONIO, TX. 78216
 OFFICE: (210) 341-6200 FAX: (210) 341-6300
 FIRM NUMBER: F-8478

PAPE-DAWSON ENGINEERS
 SAN ANTONIO | AUSTIN | HOUSTON | FORT WORTH | DALLAS
 2000 NW LOOP 410 | SAN ANTONIO, TX 78213 | 210.375.9000
 TEXAS ENGINEERING FIRM #470 | TEXAS SURVEYING FIRM #10028800

CITY OF SAN ANTONIO
PUBLIC WORKS DEPARTMENT

DOLOROSA
TRAFFIC CONTROL PLAN
 PHASE 1 STEP 1

STA 27+00 TO STA 35+00

SHEET 3 OF 3

DESIGN	CHECKED	DRAWN	PROJECT NO.	SUBMITTAL	SHEET NO.
MGR	JH	HR	23-03763	70%	43

NOTE:

TCP FROM STA 25+16 TO STA 29+50 TO REMAIN THE SAME AS PREVIOUS STEP.

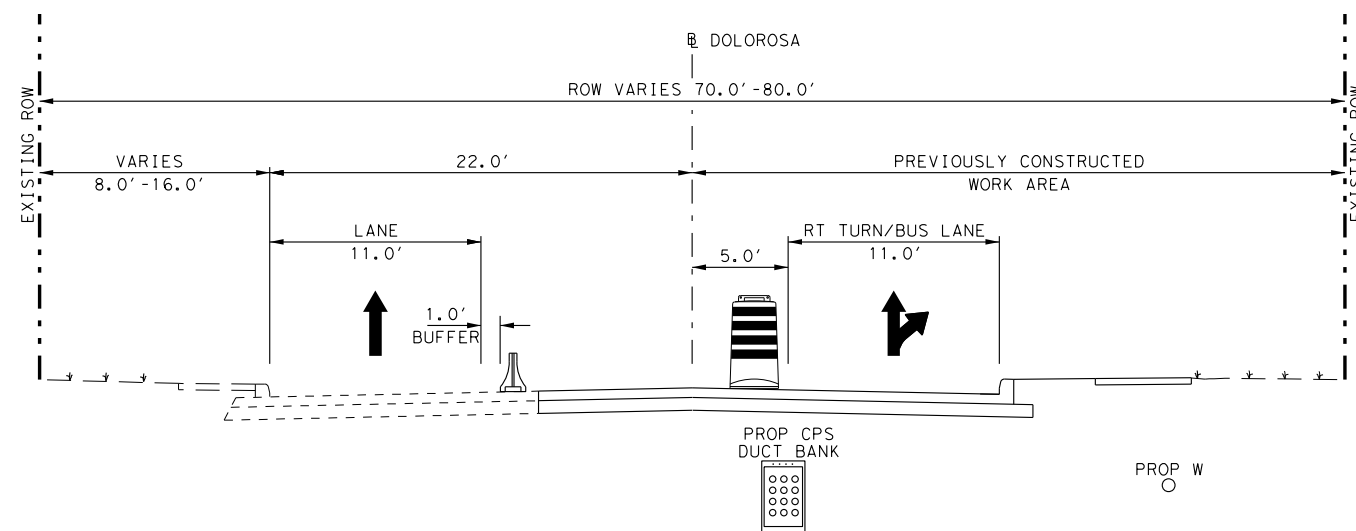

PHASE 1 STEP 2

STA 29+00.00 TO STA 31+32.50

LEGEND

- EXISTING ROADWAY
- PROPOSED ROADWAY
- WORK AREA
- ACCELERATED WORK AREA
- TEMPORARY PAVEMENT
- LOW PROFILE WATER FILL BARRIER
- VERTICAL PANELS

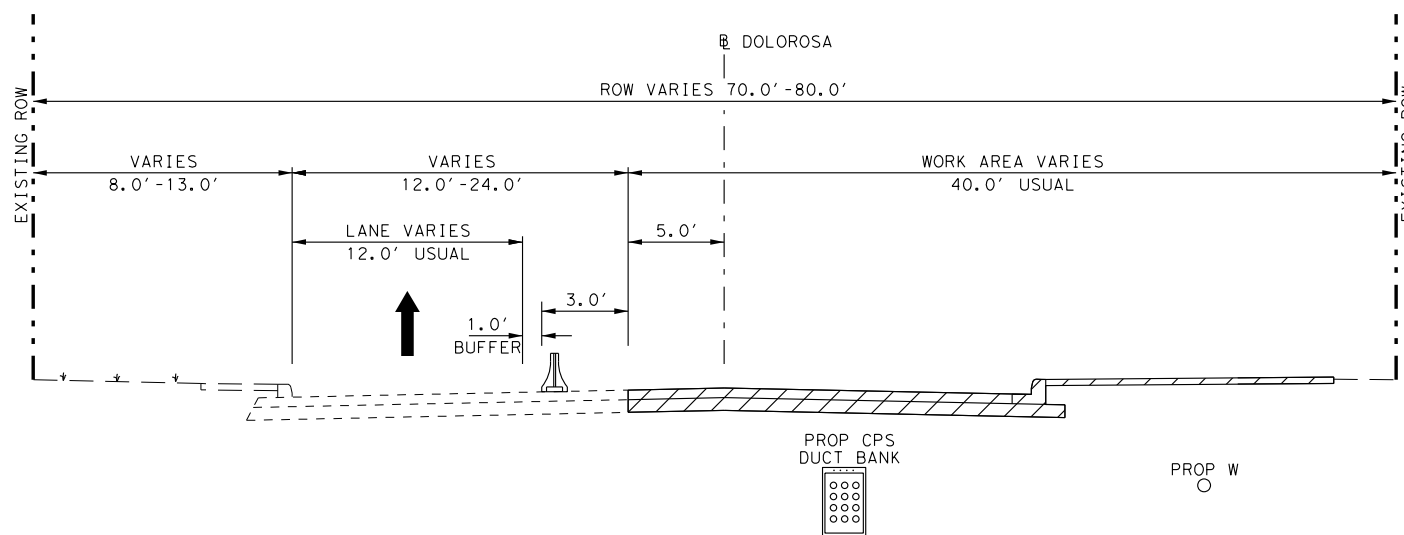

PHASE 1 STEP 2

STA 32+28.00 TO STA 35+80.00

PRELIMINARY

FOR INTERIM REVIEW ONLY

By: MICHAEL G. RAMIREZ P.E. 133983

DATE 1/23/2023

CAMACHO-HERNANDEZ & ASSOCIATES, LLC

NOT FOR CONSTRUCTION, BIDDING, OR PERMIT PURPOSES



REV. NO.	DATE	DESCRIPTION	BY
CAMACHO-HERNANDEZ & ASSOCIATES, LLC 415 EMBASSY OAKS - SUITE 205 SAN ANTONIO, TX. 78216 OFFICE: (210) 341-6200 FAX: (210) 341-6300 FIRM NUMBER: F-8478			



SAN ANTONIO | AUSTIN | HOUSTON | FORT WORTH | DALLAS
 2000 NW LOOP 410 | SAN ANTONIO, TX 78213 | 210.375.9000
 TEXAS ENGINEERING FIRM #470 | TEXAS SURVEYING FIRM #10028800



**CITY OF SAN ANTONIO
 PUBLIC WORKS DEPARTMENT**
 DOLOROSA
**TRAFFIC CONTROL PLAN
 TYPICAL SECTIONS**

PHASE 1 STEP 2





SHEET 1 OF 2

DESIGN	CHECKED	DRAWN	PROJECT NO.	SUBMITTAL	SHEET NO.
MGR	JH	HR	23-03763	70%	44

NOTE:

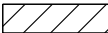
TCP FROM STA 25+16 TO STA 29+50 TO REMAIN THE SAME AS PREVIOUS STEP.

LEGEND

- EXISTING ROADWAY
- PROPOSED ROADWAY
-  WORK AREA
-  ACCELERATED WORK AREA
-  TEMPORARY PAVEMENT
-  LOW PROFILE WATER FILL BARRIER
-  VERTICAL PANELS

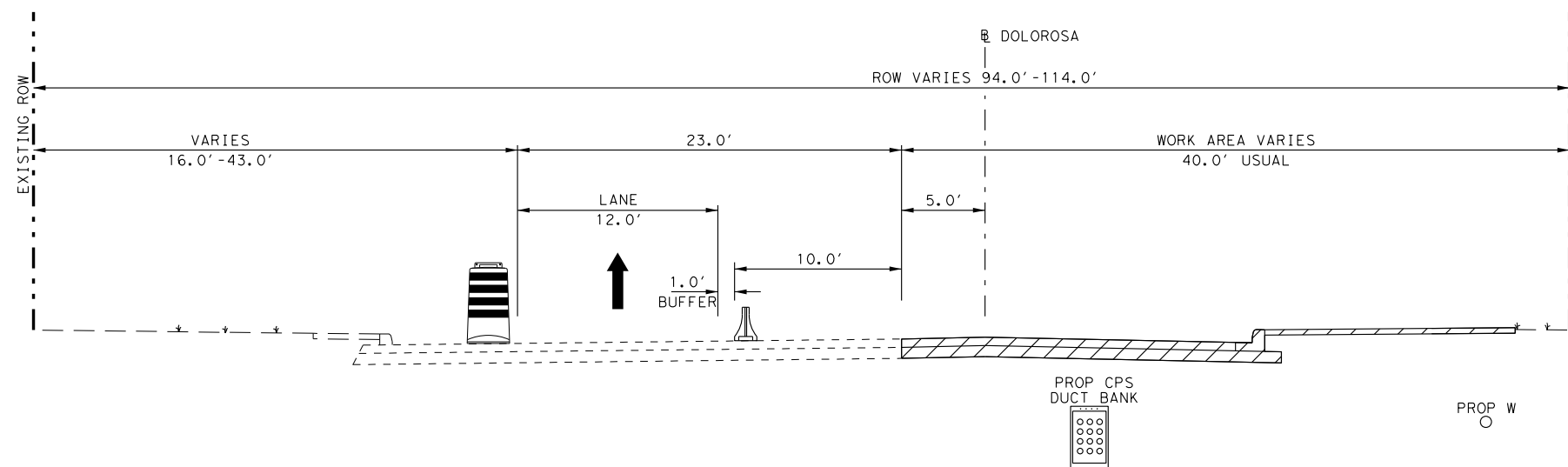

PHASE 1 STEP 2
STA 36+58.00 TO STA 42+08.00

PRELIMINARY
FOR INTERIM REVIEW ONLY
By: MICHAEL G. RAMIREZ P.E. 133983
DATE 1/23/2023
CAMACHO-HERNANDEZ & ASSOCIATES, LLC
NOT FOR CONSTRUCTION, BIDDING, OR PERMIT PURPOSES

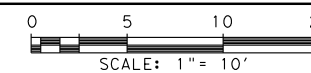

REV. NO.	DATE	DESCRIPTION	BY

CAMACHO-HERNANDEZ & ASSOCIATES, LLC
415 EMBASSY OAKS - SUITE 205 SAN ANTONIO, TX. 78216
OFFICE: (210) 341-6200 FAX: (210) 341-6300
FIRM NUMBER: F-8478

PAPE-DAWSON ENGINEERS
SAN ANTONIO | AUSTIN | HOUSTON | FORT WORTH | DALLAS
2000 NW LOOP 410 | SAN ANTONIO, TX 78213 | 210.375.9000
TEXAS ENGINEERING FIRM #470 | TEXAS SURVEYING FIRM #10028800

 **CITY OF SAN ANTONIO PUBLIC WORKS DEPARTMENT**

DOLOROSA
TRAFFIC CONTROL PLAN
TYPICAL SECTIONS

PHASE 1 STEP 2

SHEET 2 OF 2

DESIGN	CHECKED	DRAWN	PROJECT NO.	SUBMITTAL	SHEET NO.
MGR	JH	HR	23-03763	70%	45

Plotted on: 1/23/2023

Design File name: K:\COSA Dolorosa\TCP\Dolorosa_TCP_P1S2-01.dgn

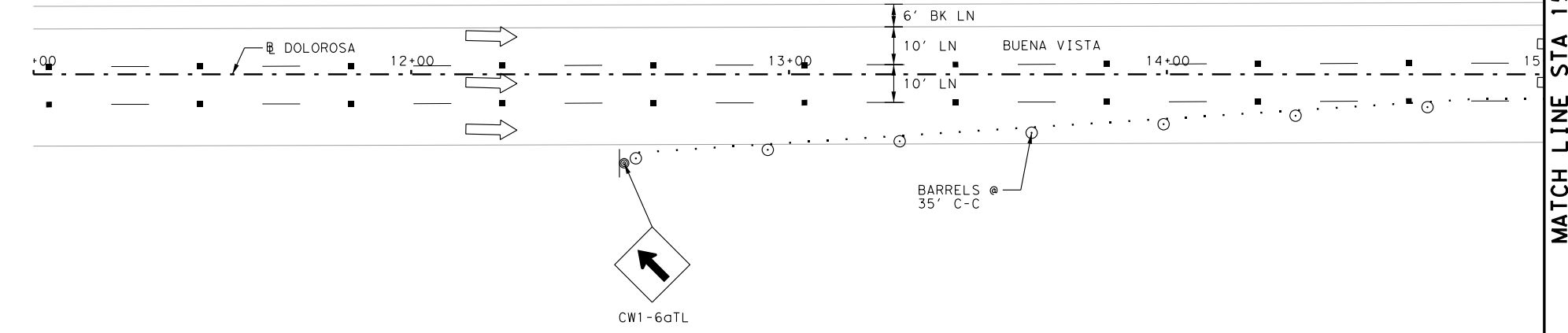
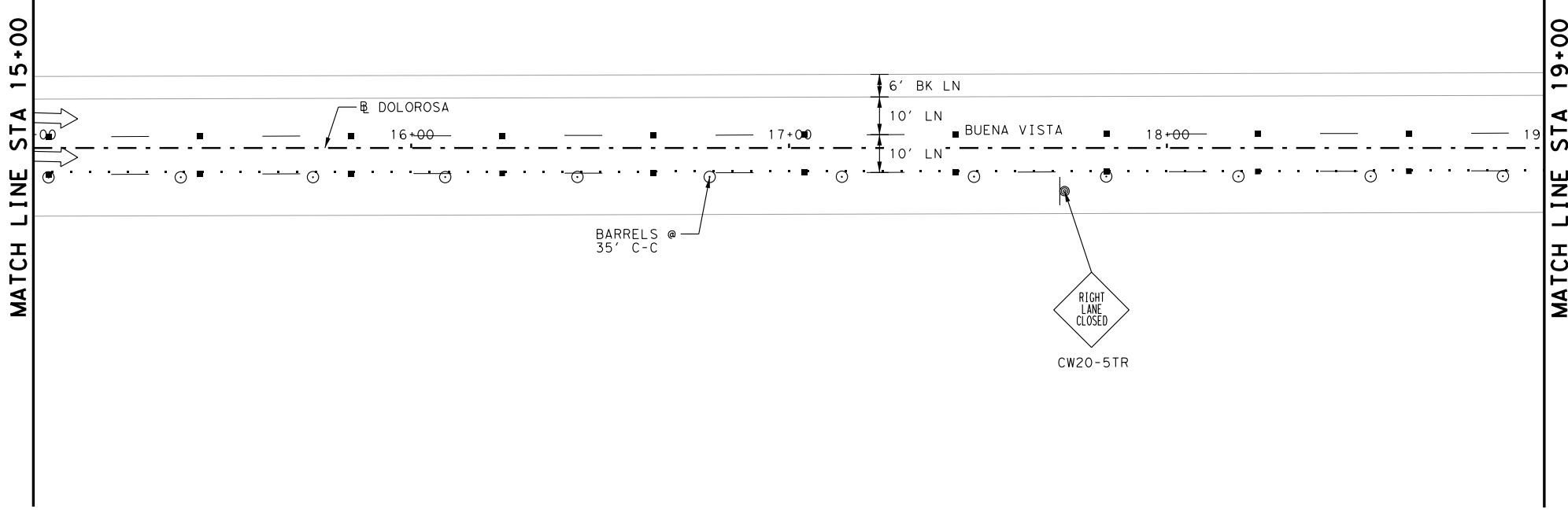

ITEM	DESCRIPTION	UNIT	QTY
540.7	CONSTRUCTION PERIMETER FENCE	LF	-
5000	WATER FILLED BARRIER	LF	-
0508-6001	CONSTRUCTING DETOURS	SY	-
0662-6063	WK ZN PAV MRK REMOV (W)4" (SLD)	LF	-
0662-6071	WK ZN PAV MRK REMOV (W)8" (SLD)	LF	-
0662-6075	WK ZN PAV MRK REMOV (W)24" (SLD)	LF	-
0667-6001	ELIM EXT PAV MRK & MRKS (4")	LF	-
0667-6003	ELIM EXT PAV MRK & MRKS (8")	LF	-
0667-6007	ELIM EXT PAV MRK & MRKS (24")	LF	-
0667-6008	ELIM EXT PAV MRK & MRKS (ARROW)	EA	-

LEGEND

- CONSTRUCTION THIS PHASE
- ACCELERATED CONSTRUCTION
- TEMPORARY BUS STOP
- TEMPORARY PAVEMENT
- DIRECTION OF TRAFFIC (TCP/EXIST)
- VERTICAL PANELS
- TYPE III BARRICADE
- CONSTRUCTION PERIMETER FENCE
- LOW PROFILE WATER FILL BARRIER
- SIGN
- PLASTIC DRUMS

NOTES:
 1. CONTRACTOR SHALL PROVIDE DRIVEWAY SIGNAGE AFFIXED TO THE TOP OF PLASTIC DRUMS AT ALL DRIVEWAY LOCATIONS.
 2. VIA IS RESPONSIBLE FOR ALL TEMPORARY BUS STOPS AND RELATED SIGNING. ONCE VIA SETS UP TEMPORARY BUS STOPS CONTRACTOR SHALL ENSURE SIGNAGE REMAINS VISIBLE.
 3. ELIMINATE PAVEMENT MARKINGS FOR CONTRACTOR INFO ONLY (NSPI.)

PRELIMINARY
 FOR INTERIM REVIEW ONLY
 By: MICHAEL G. RAMIREZ P.E. 133983
 DATE 1/23/2023
CAMACHO-HERNANDEZ & ASSOCIATES, LLC
 NOT FOR CONSTRUCTION, BIDDING, OR PERMIT PURPOSES

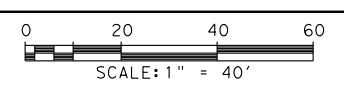

REV. NO.	DATE	DESCRIPTION	BY
CAMACHO-HERNANDEZ & ASSOCIATES, LLC 415 EMBASSY OAKS - SUITE 205 SAN ANTONIO, TX. 78216 OFFICE: (210) 341-6200 FAX: (210) 341-6300 FIRM NUMBER: F-8478			

Pape-Dawson ENGINEERS
 SAN ANTONIO | AUSTIN | HOUSTON | FORT WORTH | DALLAS
 2000 NW LOOP 410 | SAN ANTONIO, TX 78213 | 210.375.9000
 TEXAS ENGINEERING FIRM #470 | TEXAS SURVEYING FIRM #10028800

CITY OF SAN ANTONIO
PUBLIC WORKS DEPARTMENT

DOLOROSA
TRAFFIC CONTROL PLAN
 PHASE 1 STEP 2

BEGIN TO STA 19+00

SHEET 1 OF 5

DESIGN	CHECKED	DRAWN	PROJECT NO.	SUBMITTAL	SHEET NO.
MGR	JH	HR	23-03763	70%	46

Plotted on: 1/23/2023

Design File name: K:\COSA Dolorosa\TCP\Dolorosa_TCP_P1S2_02.dgn

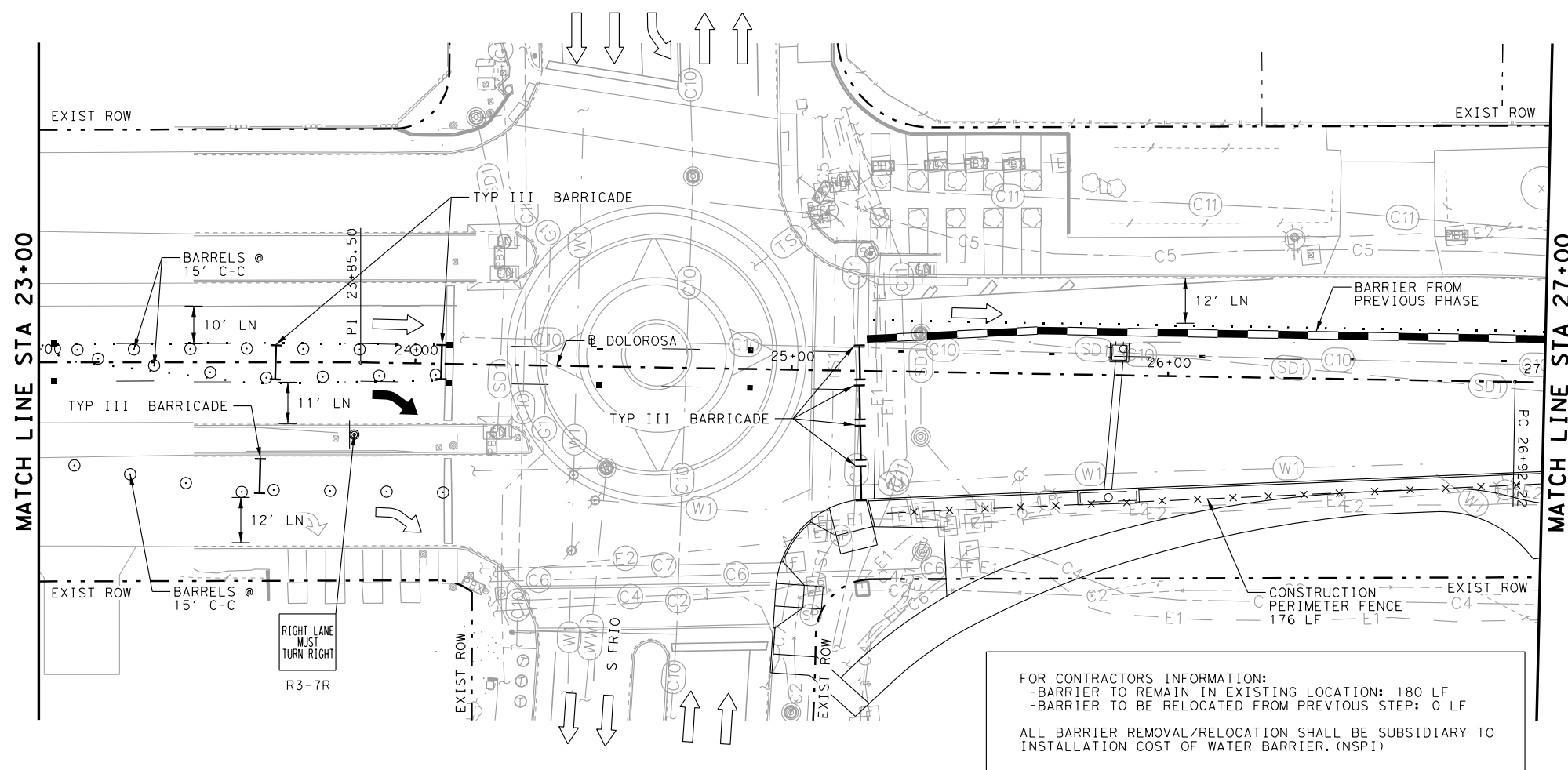
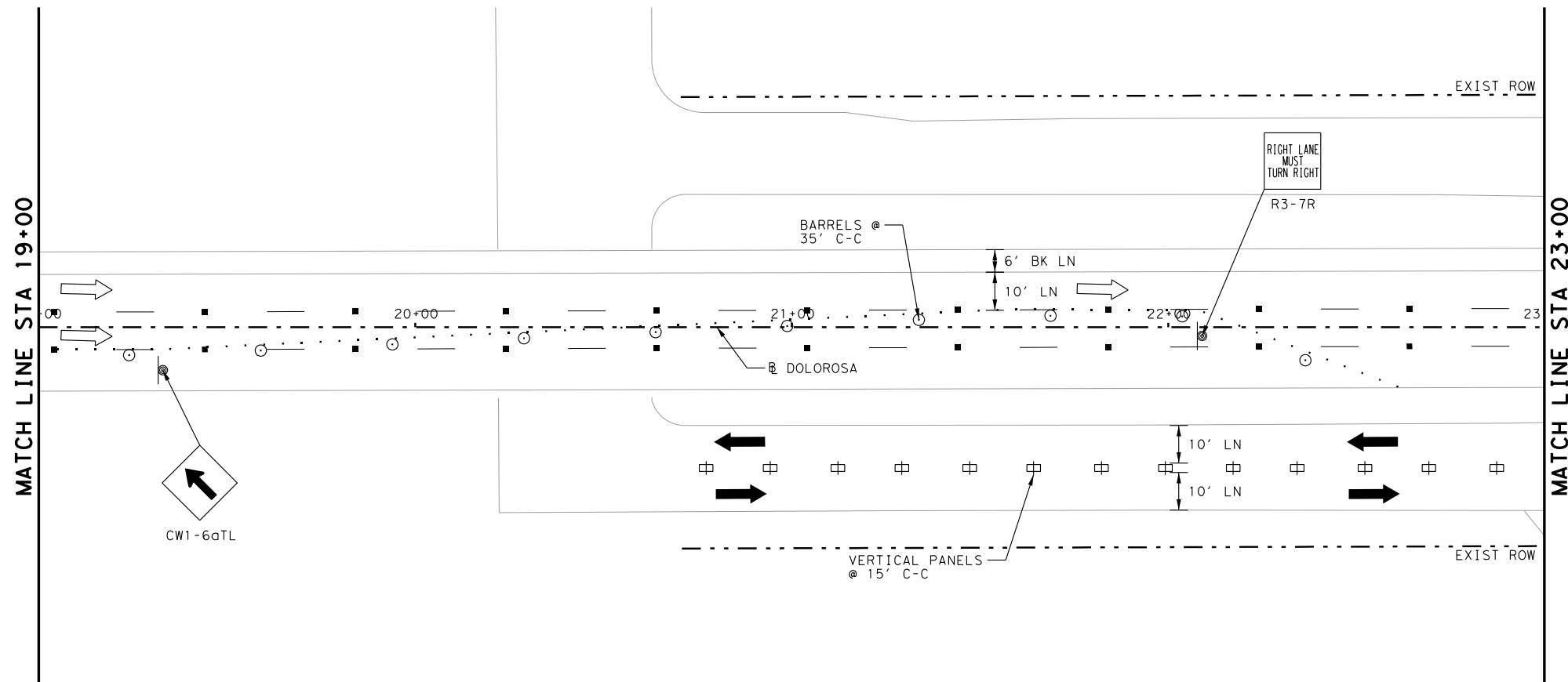

FOR CONTRACTORS INFORMATION:
 -BARRIER TO REMAIN IN EXISTING LOCATION: 180 LF
 -BARRIER TO BE RELOCATED FROM PREVIOUS STEP: 0 LF
 ALL BARRIER REMOVAL/RELOCATION SHALL BE SUBSIDIARY TO
 INSTALLATION COST OF WATER BARRIER. (NSPI)

ITEM	DESCRIPTION	UNIT	QTY
540.7	CONSTRUCTION PERIMETER FENCE	LF	176
5000	WATER FILLED BARRIER	LF	-
0508-6001	CONSTRUCTING DETOURS	SY	-
0662-6063	WK ZN PAV MRK REMOV (W)4"(SLD)	LF	-
0662-6071	WK ZN PAV MRK REMOV (W)8"(SLD)	LF	-
0662-6075	WK ZN PAV MRK REMOV (W)24"(SLD)	LF	-
0667-6001	ELIM EXT PAV MRK & MRKS (4")	LF	-
0667-6003	ELIM EXT PAV MRK & MRKS (8")	LF	-
0667-6007	ELIM EXT PAV MRK & MRKS (24")	LF	-
0667-6008	ELIM EXT PAV MRK & MRKS (ARROW)	EA	-

LEGEND

- CONSTRUCTION THIS PHASE
- ACCELERATED CONSTRUCTION
- TEMPORARY BUS STOP
- TEMPORARY PAVEMENT
- DIRECTION OF TRAFFIC (TCP/EXIST)
- VERTICAL PANELS
- TYPE III BARRICADE
- CONSTRUCTION PERIMETER FENCE
- LOW PROFILE WATER FILL BARRIER
- SIGN
- PLASTIC DRUMS

- NOTES:
- CONTRACTOR SHALL PROVIDE DRIVEWAY SIGNAGE AFFIXED TO THE TOP OF PLASTIC DRUMS AT ALL DRIVEWAY LOCATIONS.
 - VIA IS RESPONSIBLE FOR ALL TEMPORARY BUS STOPS AND RELATED SIGNING. ONCE VIA SETS UP TEMPORARY BUS STOPS CONTRACTOR SHALL ENSURE SIGNAGE REMAINS VISIBLE.
 - ELIMINATE PAVEMENT MARKINGS FOR CONTRACTOR INFO ONLY (NSPI.)

PRELIMINARY
 FOR INTERIM REVIEW ONLY

By: MICHAEL G. RAMIREZ P.E. 133983
 DATE 1/23/2023

CAMACHO-HERNANDEZ & ASSOCIATES, LLC
 NOT FOR CONSTRUCTION, BIDDING, OR PERMIT PURPOSES

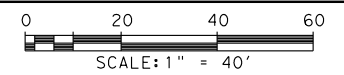

REV. NO.	DATE	DESCRIPTION	BY

CAMACHO-HERNANDEZ & ASSOCIATES, LLC
 415 EMBASSY OAKS - SUITE 205 SAN ANTONIO, TX. 78216
 OFFICE: (210) 341-6200 FAX: (210) 341-6300
 FIRM NUMBER: F-8478

Pape-Dawson ENGINEERS

SAN ANTONIO | AUSTIN | HOUSTON | FORT WORTH | DALLAS
 2000 NW LOOP 410 | SAN ANTONIO, TX 78213 | 210.375.9000
 TEXAS ENGINEERING FIRM #470 | TEXAS SURVEYING FIRM #10028800

CITY OF SAN ANTONIO
PUBLIC WORKS DEPARTMENT

DOLOROSA
TRAFFIC CONTROL PLAN
 PHASE 1 STEP 2

STA 19+00 TO STA 27+00

SHEET 2 OF 5

DESIGN	CHECKED	DRAWN	PROJECT NO.	SUBMITTAL	SHEET NO.
MGR	JH	HR	23-03763	70%	47

Plotted on: 1/23/2023

Design File name: K:\COSA Dolorosa\TCP\Dolorosa_TCP_P1S2-03.dgn

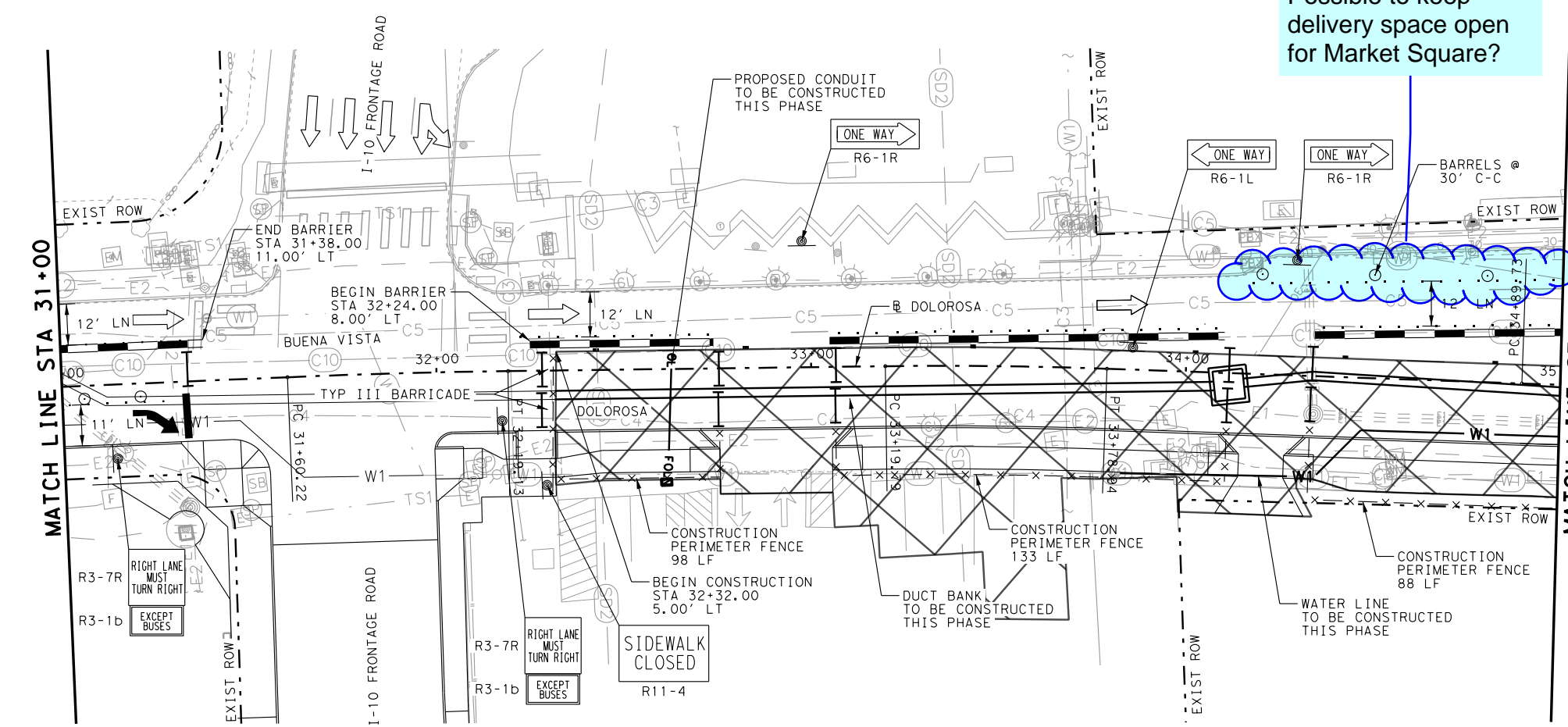
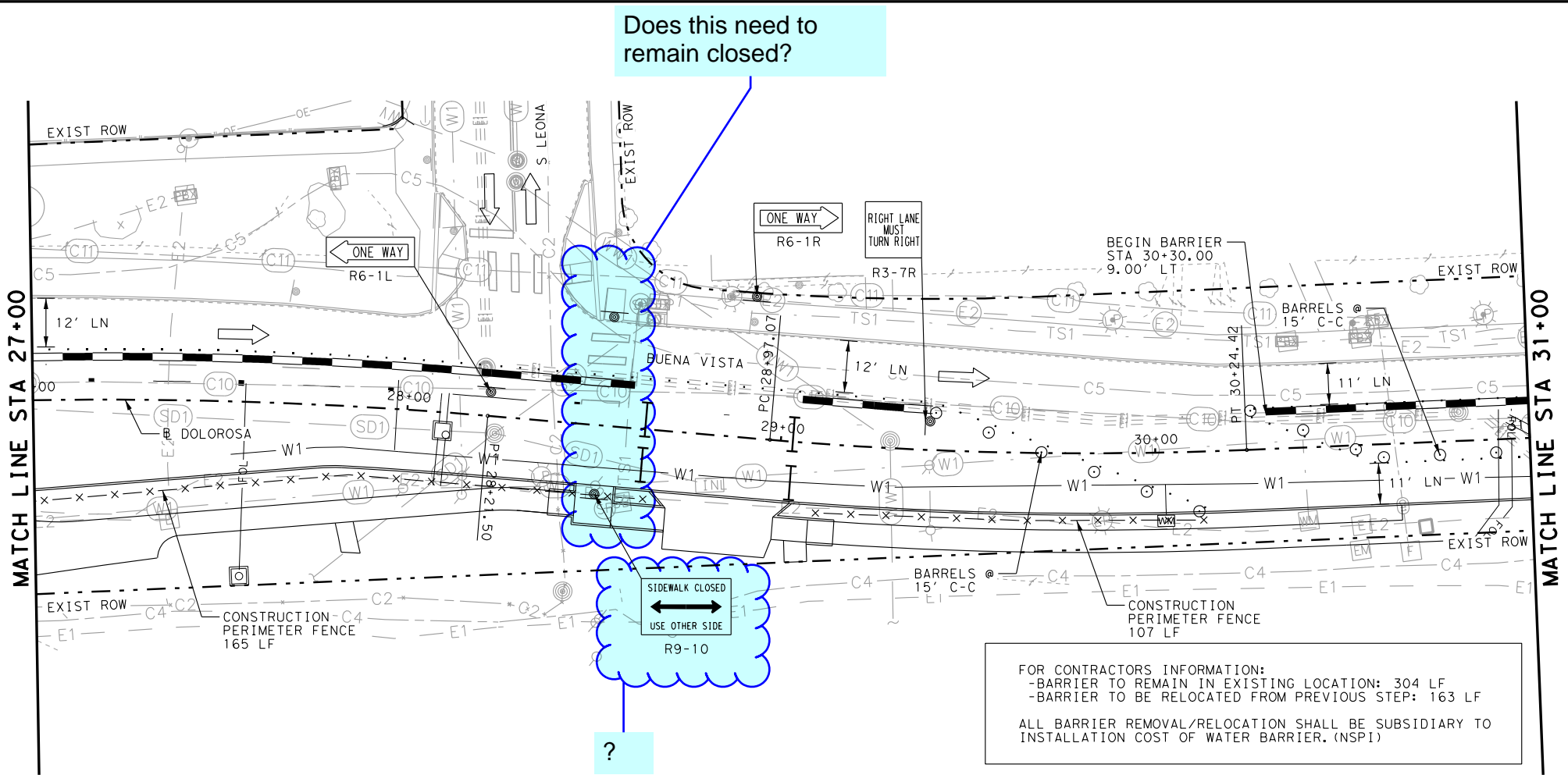

ITEM	DESCRIPTION	UNIT	QTY
540.7	CONSTRUCTION PERIMETER FENCE	LF	591
5000	WATER FILLED BARRIER	LF	57
0508-6001	CONSTRUCTING DETOURS	SY	-
0662-6063	WK ZN PAV MRK REMOV (W)4" (SLD)	LF	500
0662-6071	WK ZN PAV MRK REMOV (W)8" (SLD)	LF	108
0662-6075	WK ZN PAV MRK REMOV (W)24" (SLD)	LF	12
0667-6001	ELIM EXT PAV MRK & MRKS (4")	LF	111
0667-6003	ELIM EXT PAV MRK & MRKS (8")	LF	20
0667-6007	ELIM EXT PAV MRK & MRKS (24")	LF	-
0667-6008	ELIM EXT PAV MRK & MRKS (ARROW)	EA	-

LEGEND

- CONSTRUCTION THIS PHASE
- ACCELERATED CONSTRUCTION
- TEMPORARY BUS STOP
- TEMPORARY PAVEMENT
- DIRECTION OF TRAFFIC (TCP/EXIST)
- VERTICAL PANELS
- TYPE III BARRICADE
- CONSTRUCTION PERIMETER FENCE
- LOW PROFILE WATER FILL BARRIER
- SIGN
- PLASTIC DRUMS

- NOTES:
- CONTRACTOR SHALL PROVIDE DRIVEWAY SIGNAGE AFFIXED TO THE TOP OF PLASTIC DRUMS AT ALL DRIVEWAY LOCATIONS.
 - VIA IS RESPONSIBLE FOR ALL TEMPORARY BUS STOPS AND RELATED SIGNING. ONCE VIA SETS UP TEMPORARY BUS STOPS CONTRACTOR SHALL ENSURE SIGNAGE REMAINS VISIBLE.
 - ELIMINATE PAVEMENT MARKINGS FOR CONTRACTOR INFO ONLY (NSPI.)

PRELIMINARY
FOR INTERIM REVIEW ONLY

By: MICHAEL G. RAMIREZ P.E. 133983
DATE 1/23/2023

CAMACHO-HERNANDEZ & ASSOCIATES, LLC
NOT FOR CONSTRUCTION, BIDDING, OR PERMIT PURPOSES

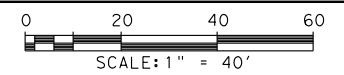

REV. NO.	DATE	DESCRIPTION	BY

CAMACHO-HERNANDEZ & ASSOCIATES, LLC
415 EMBASSY OAKS - SUITE 205 SAN ANTONIO, TX. 78216
OFFICE: (210) 341-6200 FAX: (210) 341-6300
FIRM NUMBER: F-8478

PAPE-DAWSON ENGINEERS

SAN ANTONIO | AUSTIN | HOUSTON | FORT WORTH | DALLAS
2000 NW LOOP 410 | SAN ANTONIO, TX 78213 | 210.375.9000
TEXAS ENGINEERING FIRM #470 | TEXAS SURVEYING FIRM #10028800

CITY OF SAN ANTONIO
PUBLIC WORKS DEPARTMENT

DOLOROSA
TRAFFIC CONTROL PLAN
PHASE 1 STEP 2

STA 27+00 TO STA 35+00

SHEET 3 OF 5

DESIGN	CHECKED	DRAWN	PROJECT NO.	SUBMITTAL	SHEET NO.
MGR	JH	HR	23-03763	70%	48

Plotted on: 1/23/2023

Design File name: K:\COSA Dolorosa\TCP\Dolorosa_TCP_P1S2-04.dgn

Possible to keep delivery space open for Market Square?

? There are a lot of these CW1-4. Check applicability. Sign clutter should be minimized.

Need alternate to barrels in front of Mi Tierra driveways?

Where is their access? How do people know?

Ped. Detour.

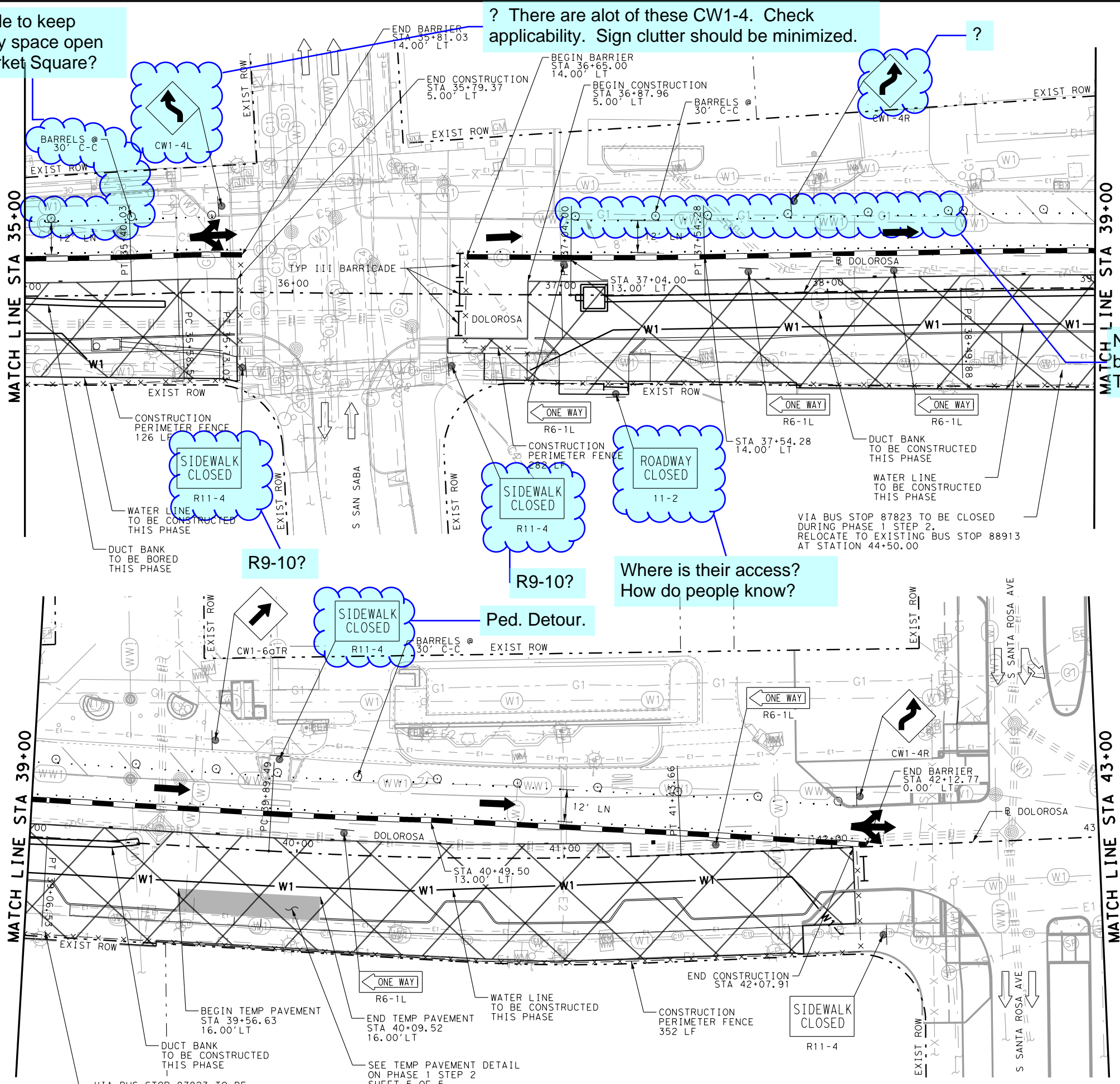

ITEM	DESCRIPTION	UNIT	QTY
540.7	CONSTRUCTION PERIMETER FENCE	LF	760
5000	WATER FILLED BARRIER	LF	547
0508-6001	CONSTRUCTING DETOURS	SY	53
0662-6063	WK ZN PAV MRK REMOV (W)4" (SLD)	LF	1209
0662-6071	WK ZN PAV MRK REMOV (W)8" (SLD)	LF	-
0662-6075	WK ZN PAV MRK REMOV (W)24" (SLD)	LF	-
0667-6001	ELIM EXT PAV MRK & MRKS (4")	LF	68
0667-6003	ELIM EXT PAV MRK & MRKS (8")	LF	397
0667-6007	ELIM EXT PAV MRK & MRKS (24")	LF	84
0667-6008	ELIM EXT PAV MRK & MRKS (ARROW)	EA	1

LEGEND

- CONSTRUCTION THIS PHASE
- ACCELERATED CONSTRUCTION
- TEMPORARY BUS STOP
- TEMPORARY PAVEMENT
- DIRECTION OF TRAFFIC (TCP/EXIST)
- VERTICAL PANELS
- TYPE III BARRICADE
- CONSTRUCTION PERIMETER FENCE
- LOW PROFILE WATER FILL BARRIER
- SIGN
- PLASTIC DRUMS

NOTES:
 1. CONTRACTOR SHALL PROVIDE DRIVEWAY SIGNAGE AFFIXED TO THE TOP OF PLASTIC DRUMS AT ALL DRIVEWAY LOCATIONS.
 2. VIA IS RESPONSIBLE FOR ALL TEMPORARY BUS STOPS AND RELATED SIGNING. ONCE VIA SETS UP TEMPORARY BUS STOPS CONTRACTOR SHALL ENSURE SIGNAGE REMAINS VISIBLE.
 3. ELIMINATE PAVEMENT MARKINGS FOR CONTRACTOR INFO ONLY (NSP1.)

PRELIMINARY
 FOR INTERIM REVIEW ONLY
 By: MICHAEL G. RAMIREZ P.E. 133983
 DATE 1/23/2023
CAMACHO-HERNANDEZ & ASSOCIATES, LLC
 NOT FOR CONSTRUCTION, BIDDING, OR PERMIT PURPOSES

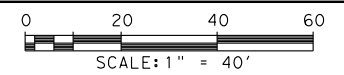

REV. NO.	DATE	DESCRIPTION	BY

CAMACHO-HERNANDEZ & ASSOCIATES, LLC
 415 EMBASSY OAKS - SUITE 205 SAN ANTONIO, TX. 78216
 OFFICE: (210) 341-6200 FAX: (210) 341-6300
 FIRM NUMBER: F-8478

PAPE-DAWSON ENGINEERS
 SAN ANTONIO | AUSTIN | HOUSTON | FORT WORTH | DALLAS
 2000 NW LOOP 410 | SAN ANTONIO, TX 78213 | 210.375.9000
 TEXAS ENGINEERING FIRM #470 | TEXAS SURVEYING FIRM #10028800

CITY OF SAN ANTONIO
PUBLIC WORKS DEPARTMENT

DOLOROSA
TRAFFIC CONTROL PLAN
 PHASE 1 STEP 2

STA 35+00 TO STA 43+00

SHEET 4 OF 5

DESIGN	CHECKED	DRAWN	PROJECT NO.	SUBMITTAL	SHEET NO.
MGR	JH	HR	23-03763	70%	49

Plotted on: 1/23/2023

Design File name: K:\COSA Dolorosa\TCP\Dolorosa_TCP_P1S2-05.dgn

Add language to coordinate with Landscape Architect and City Arborist. (Typ)

Is this included in pay item? Show limits of payment in detail.

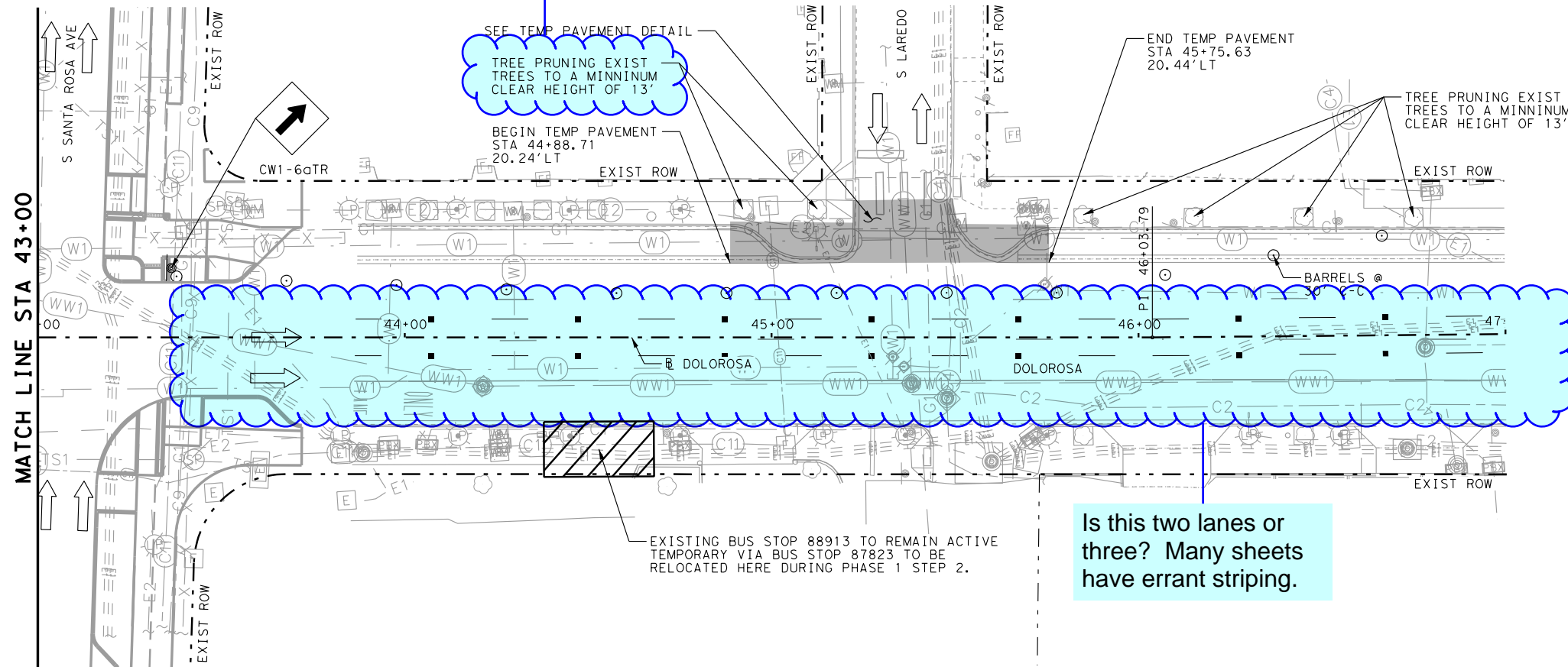
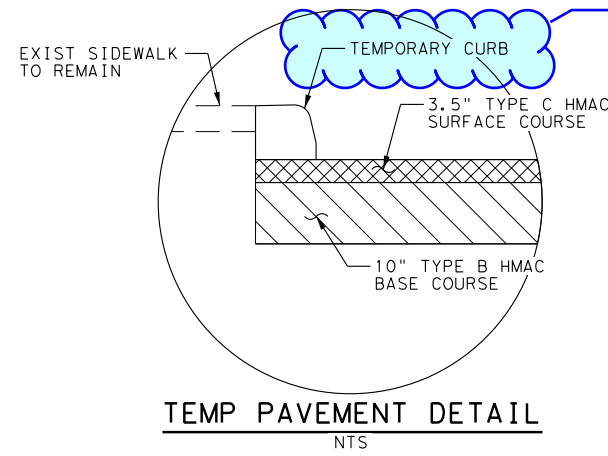

ITEM	DESCRIPTION	UNIT	QTY
540.7	CONSTRUCTION PERIMETER FENCE	LF	-
5000	WATER FILLED BARRIER	LF	-
0508-6001	CONSTRUCTING DETOURS	SY	125
0662-6063	WK ZN PAV MRK REMOV (W)4\" (SLD)	LF	-
0662-6071	WK ZN PAV MRK REMOV (W)8\" (SLD)	LF	-
0662-6075	WK ZN PAV MRK REMOV (W)24\" (SLD)	LF	-
0667-6001	ELIM EXT PAV MRK & MRKS (4\")	LF	-
0667-6003	ELIM EXT PAV MRK & MRKS (8\")	LF	-
0667-6007	ELIM EXT PAV MRK & MRKS (24\")	LF	-
0667-6008	ELIM EXT PAV MRK & MRKS (ARROW)	EA	-

LEGEND

- CONSTRUCTION THIS PHASE
- ACCELERATED CONSTRUCTION
- TEMPORARY BUS STOP
- TEMPORARY PAVEMENT
- DIRECTION OF TRAFFIC (TCP/EXIST)
- VERTICAL PANELS
- TYPE III BARRICADE
- CONSTRUCTION PERIMETER FENCE
- LOW PROFILE WATER FILL BARRIER
- SIGN
- PLASTIC DRUMS

- NOTES:
- CONTRACTOR SHALL PROVIDE DRIVEWAY SIGNAGE AFFIXED TO THE TOP OF PLASTIC DRUMS AT ALL DRIVEWAY LOCATIONS.
 - VIA IS RESPONSIBLE FOR ALL TEMPORARY BUS STOPS AND RELATED SIGNING. ONCE VIA SETS UP TEMPORARY BUS STOPS CONTRACTOR SHALL ENSURE SIGNAGE REMAINS VISIBLE.
 - ELIMINATE PAVEMENT MARKINGS FOR CONTRACTOR INFO ONLY (NSP1.)

PRELIMINARY
FOR INTERIM REVIEW ONLY

By: MICHAEL G. RAMIREZ P.E. 133983
DATE 1/23/2023

CAMACHO-HERNANDEZ & ASSOCIATES, LLC
NOT FOR CONSTRUCTION, BIDDING, OR PERMIT PURPOSES

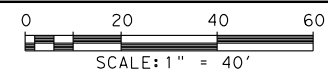

REV. NO.	DATE	DESCRIPTION	BY

CAMACHO-HERNANDEZ & ASSOCIATES, LLC
415 EMBASSY OAKS - SUITE 205 SAN ANTONIO, TX. 78216
OFFICE: (210) 341-6200 FAX: (210) 341-6300
FIRM NUMBER: F-8478

Pape-Dawson ENGINEERS

SAN ANTONIO | AUSTIN | HOUSTON | FORT WORTH | DALLAS
2000 NW LOOP 410 | SAN ANTONIO, TX 78213 | 210.375.9000
TEXAS ENGINEERING FIRM #470 | TEXAS SURVEYING FIRM #10028800

CITY OF SAN ANTONIO
PUBLIC WORKS DEPARTMENT

DOLOROSA
TRAFFIC CONTROL PLAN
PHASE 1 STEP 2

STA 43+00 TO STA 47+00

SHEET 5 OF 5

DESIGN	CHECKED	DRAWN	PROJECT NO.	SUBMITTAL	SHEET NO.
MGR	JH	HR	23-03763	70%	50

Is this two lanes or three? Many sheets have errant striping.

SEE TEMP PAVEMENT DETAIL
TREE PRUNING EXIST TREES TO A MINIMUM CLEAR HEIGHT OF 13'

BEGIN TEMP PAVEMENT
STA 44+88.71
20.24' LT

END TEMP PAVEMENT
STA 45+75.63
20.44' LT

TREE PRUNING EXIST TREES TO A MINIMUM CLEAR HEIGHT OF 13'

EXISTING BUS STOP 88913 TO REMAIN ACTIVE TEMPORARY VIA BUS STOP 87823 TO BE RELOCATED HERE DURING PHASE 1 STEP 2.

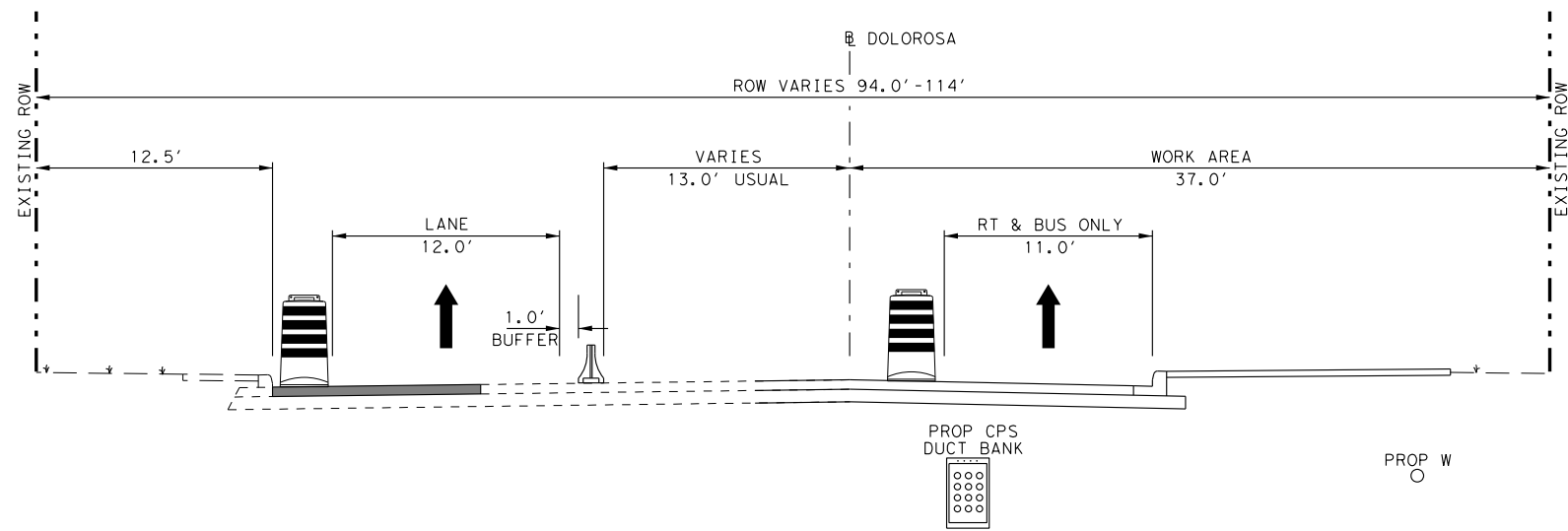

PHASE 1 STEP 3

STA 38+00.00 TO STA 42+00.00

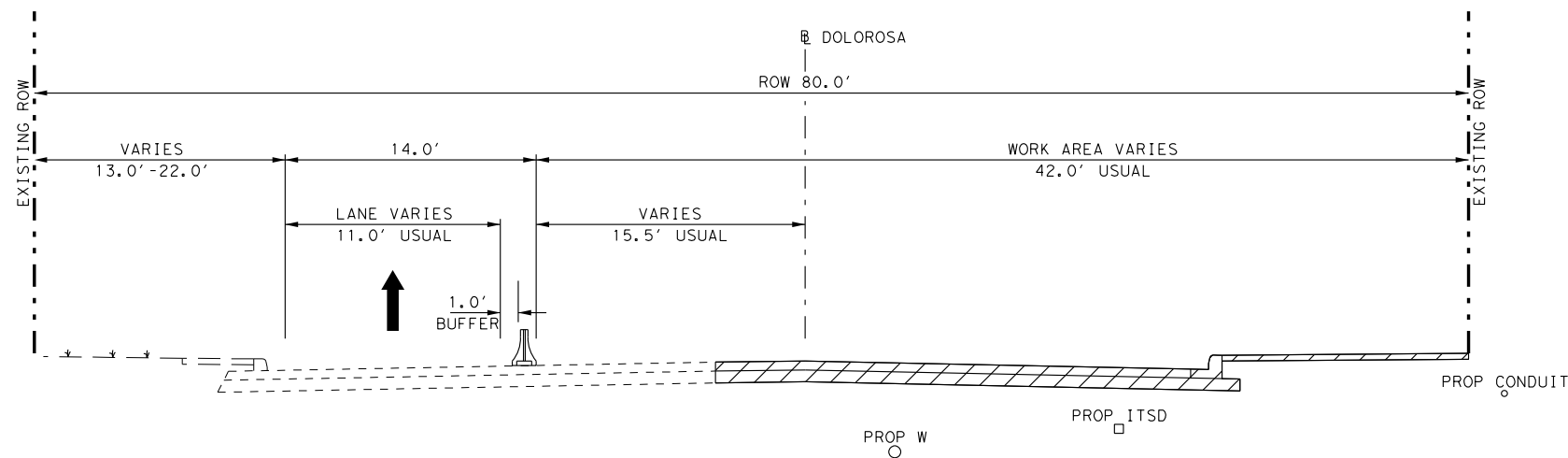

PHASE 1 STEP 3

STA 43+50.00 TO STA 48+27.00

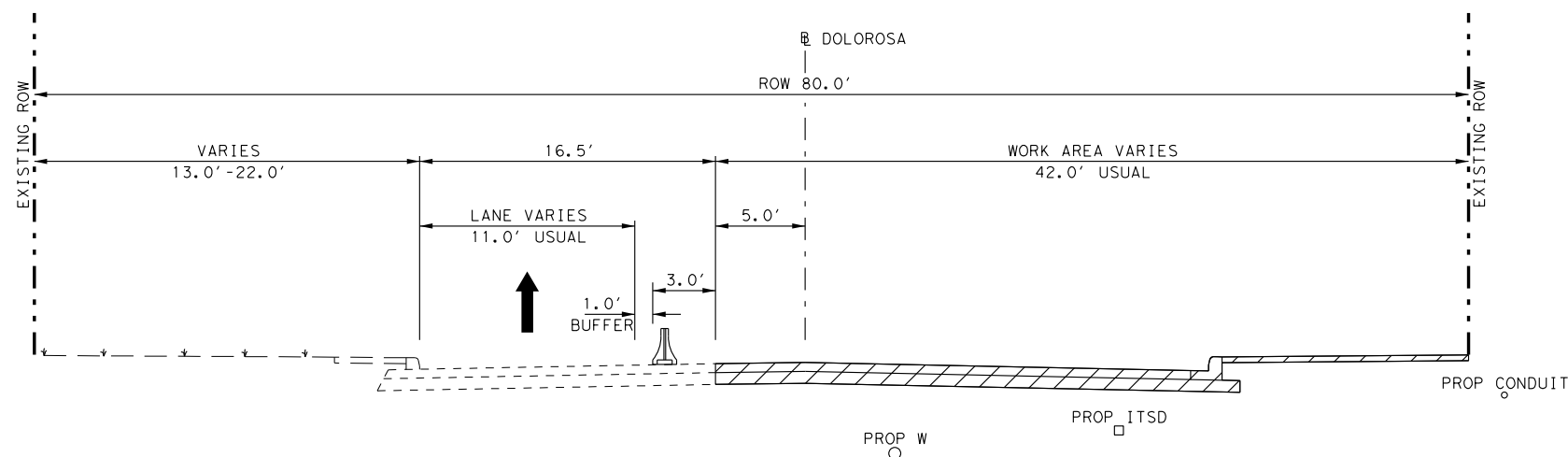

PHASE 1 STEP 3

STA 48+27.00 TO STA 53+82.00

NOTE:

TCP FROM STA 25+16 TO STA 43+50 TO REMAIN THE SAME AS PREVIOUS STEP.

LEGEND

- EXISTING ROADWAY
- PROPOSED ROADWAY
- WORK AREA
- ACCELERATED WORK AREA
- TEMPORARY PAVEMENT
- LOW PROFILE WATER FILL BARRIER
- VERTICAL PANELS

PRELIMINARY
FOR INTERIM REVIEW ONLY

By: MICHAEL G. RAMIREZ P.E. 133983
DATE 1/23/2023

CAMACHO-HERNANDEZ & ASSOCIATES, LLC
NOT FOR CONSTRUCTION, BIDDING, OR PERMIT PURPOSES

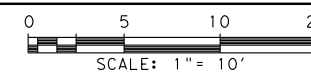

REV. NO.	DATE	DESCRIPTION	BY
CAMACHO-HERNANDEZ & ASSOCIATES, LLC 415 EMBASSY OAKS - SUITE 205 SAN ANTONIO, TX. 78216 OFFICE: (210) 341-6200 FAX: (210) 341-6300 FIRM NUMBER: F-8478			

Pape-Dawson ENGINEERS

SAN ANTONIO | AUSTIN | HOUSTON | FORT WORTH | DALLAS
2000 NW LOOP 410 | SAN ANTONIO, TX 78213 | 210.375.9000
TEXAS ENGINEERING FIRM #470 | TEXAS SURVEYING FIRM #10028800

CITY OF SAN ANTONIO
PUBLIC WORKS DEPARTMENT

DOLOROSA
TRAFFIC CONTROL PLAN
TYPICAL SECTIONS

PHASE 1 STEP 3

SHEET 1 OF 1

DESIGN	CHECKED	DRAWN	PROJECT NO.	SUBMITTAL	SHEET NO.
MGR	JH	HR	23-03763	70%	51

Plotted on: 1/23/2023

Design File name: K:\COSA Dolorosa\TCP\Dolorosa_TCP_P1S3_01.dgn

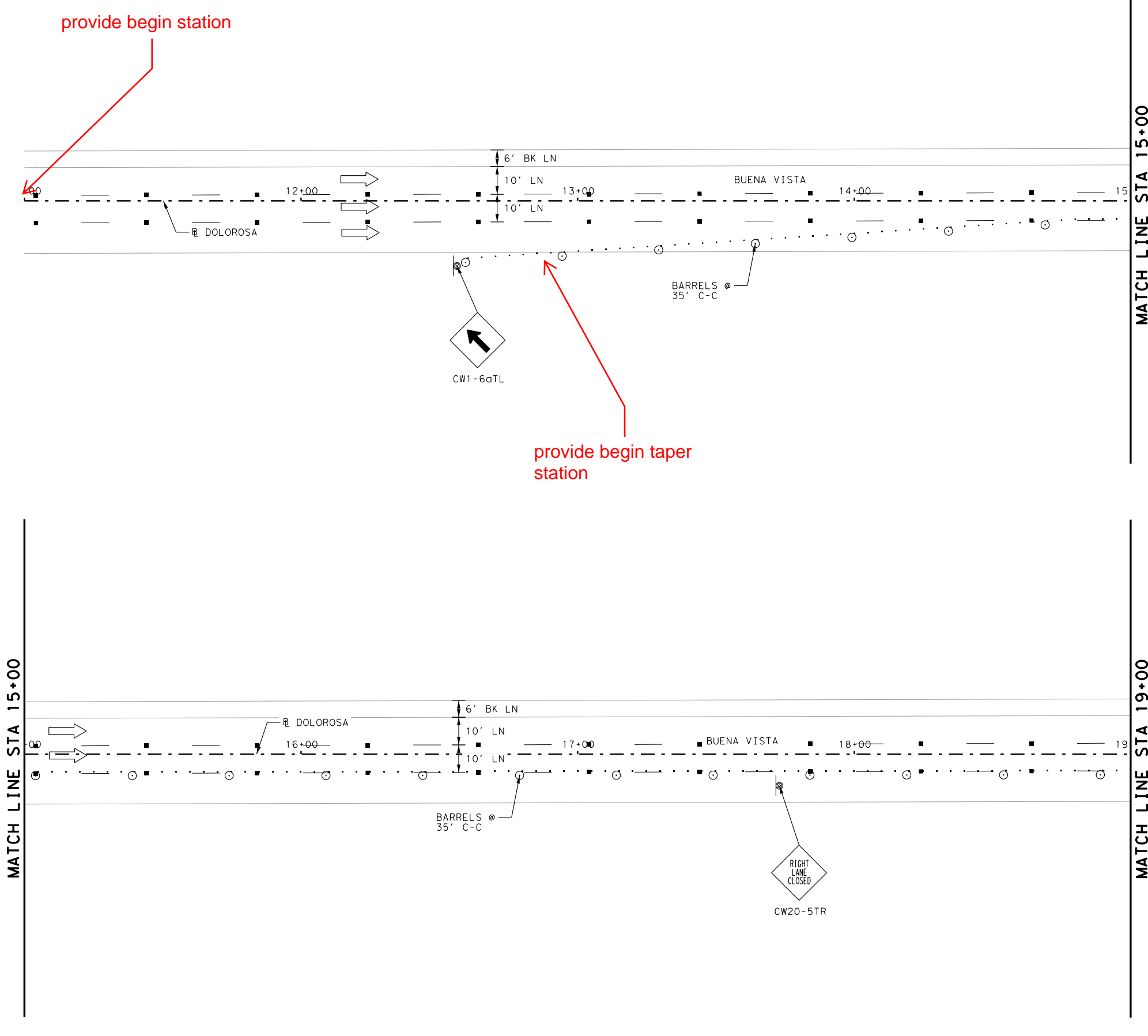

ITEM	DESCRIPTION	UNIT	QTY
540.7	CONSTRUCTION PERIMETER FENCE	LF	-
5000	WATER FILLED BARRIER	LF	-
0508-6001	CONSTRUCTING DETOURS	SY	-
0662-6063	WK ZN PAV MRK REMOV (W)4" (SLD)	LF	-
0662-6071	WK ZN PAV MRK REMOV (W)8" (SLD)	LF	-
0662-6075	WK ZN PAV MRK REMOV (W)24" (SLD)	LF	-
0667-6001	ELIM EXT PAV MRK & MRKS (4")	LF	-
0667-6003	ELIM EXT PAV MRK & MRKS (8")	LF	-
0667-6007	ELIM EXT PAV MRK & MRKS (24")	LF	-
0667-6008	ELIM EXT PAV MRK & MRKS (ARROW)	EA	-

LEGEND

- CONSTRUCTION THIS PHASE
- ACCELERATED CONSTRUCTION
- TEMPORARY BUS STOP
- TEMPORARY PAVEMENT
- DIRECTION OF TRAFFIC (TCP/EXIST)
- VERTICAL PANELS
- TYPE III BARRICADE
- CONSTRUCTION PERIMETER FENCE
- LOW PROFILE WATER FILL BARRIER
- SIGN
- PLASTIC DRUMS

NOTES:
 1. CONTRACTOR SHALL PROVIDE DRIVEWAY SIGNAGE AFFIXED TO THE TOP OF PLASTIC DRUMS AT ALL DRIVEWAY LOCATIONS.
 2. VIA IS RESPONSIBLE FOR ALL TEMPORARY BUS STOPS AND RELATED SIGNING. ONCE VIA SETS UP TEMPORARY BUS STOPS CONTRACTOR SHALL ENSURE SIGNAGE REMAINS VISIBLE.
 3. ELIMINATE PAVEMENT MARKINGS FOR CONTRACTOR INFO ONLY (NSPI.)

PRELIMINARY
 FOR INTERIM REVIEW ONLY

By: MICHAEL G. RAMIREZ P.E. 133983
 DATE 1/23/2023

CAMACHO-HERNANDEZ & ASSOCIATES, LLC
 NOT FOR CONSTRUCTION, BIDDING, OR PERMIT PURPOSES



REV. NO.	DATE	DESCRIPTION	BY
CAMACHO-HERNANDEZ & ASSOCIATES, LLC 415 EMBASSY OAKS - SUITE 205 SAN ANTONIO, TX. 78216 OFFICE: (210) 341-6200 FAX: (210) 341-6300 FIRM NUMBER: F-8478			

PAPE-DAWSON ENGINEERS

SAN ANTONIO | AUSTIN | HOUSTON | FORT WORTH | DALLAS
 2000 NW LOOP 410 | SAN ANTONIO, TX 78213 | 210.375.9000
 TEXAS ENGINEERING FIRM #470 | TEXAS SURVEYING FIRM #10028800

CITY OF SAN ANTONIO
PUBLIC WORKS DEPARTMENT

DOLOROSA
TRAFFIC CONTROL PLAN
 PHASE 1 STEP 3

BEGIN TO STA 19+00

SHEET 1 OF 6

DESIGN	CHECKED	DRAWN	PROJECT NO.	SUBMITTAL	SHEET NO.
MGR	JH	HR	23-03763	70%	52

Plotted on: 1/23/2023

Design File name: K:\COSA Dolorosa\TCP\Dolorosa_TCP_P1S3_02.dgn

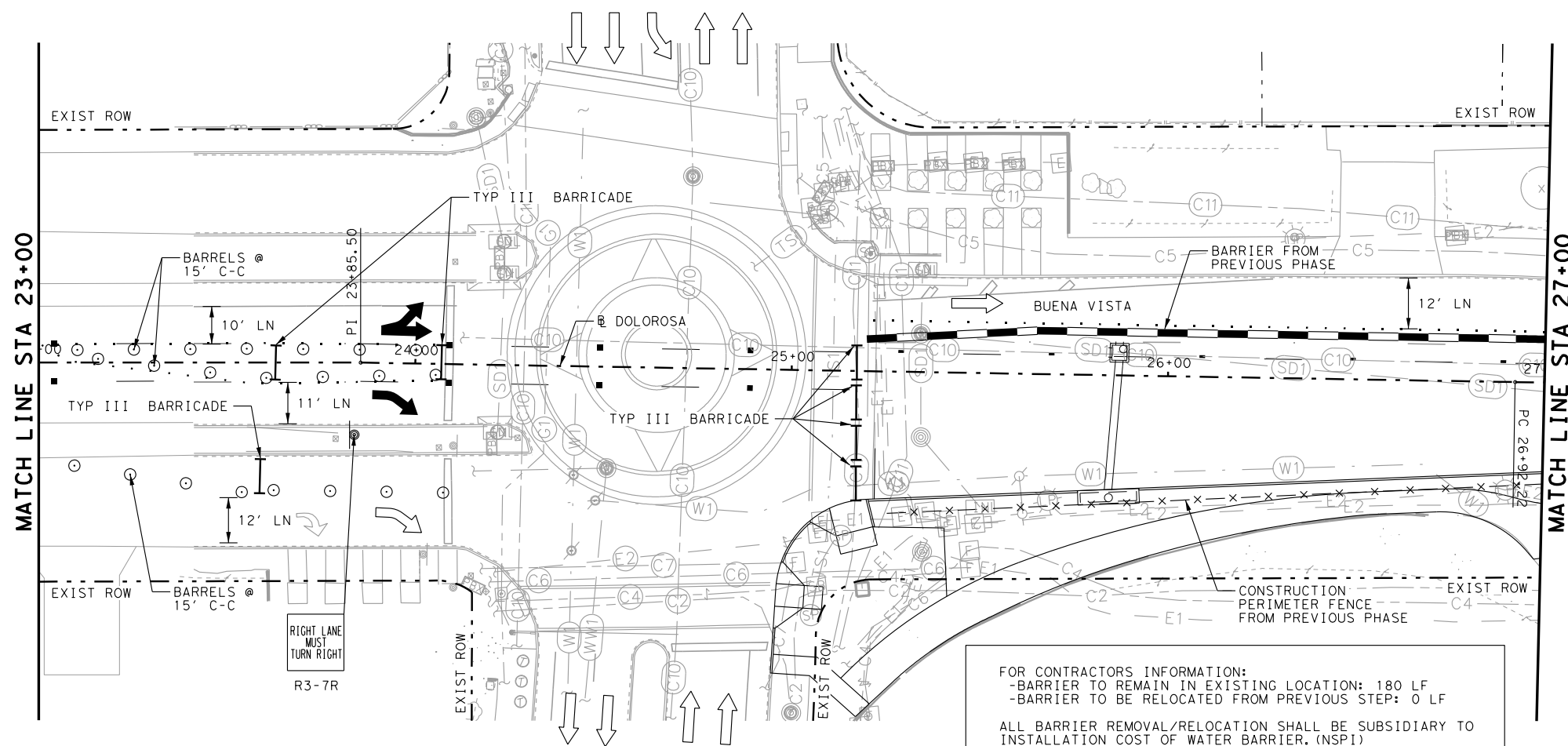
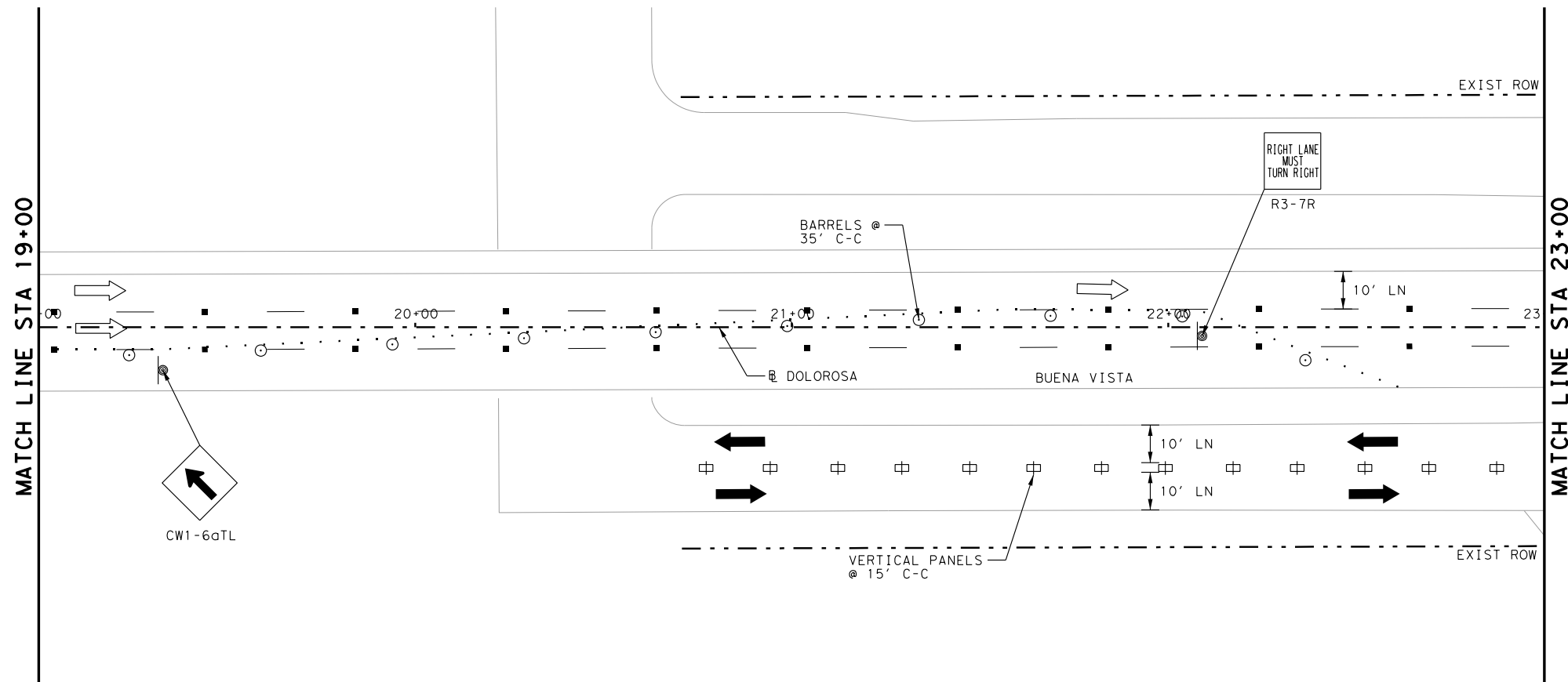

ITEM	DESCRIPTION	UNIT	QTY
540.7	CONSTRUCTION PERIMETER FENCE	LF	-
5000	WATER FILLED BARRIER	LF	-
0508-6001	CONSTRUCTING DETOURS	SY	-
0662-6063	WK ZN PAV MRK REMOV (W)4"(SLD)	LF	-
0662-6071	WK ZN PAV MRK REMOV (W)8"(SLD)	LF	-
0662-6075	WK ZN PAV MRK REMOV (W)24"(SLD)	LF	-
0667-6001	ELIM EXT PAV MRK & MRKS (4")	LF	-
0667-6003	ELIM EXT PAV MRK & MRKS (8")	LF	-
0667-6007	ELIM EXT PAV MRK & MRKS (24")	LF	-
0667-6008	ELIM EXT PAV MRK & MRKS (ARROW)	EA	-

LEGEND

- CONSTRUCTION THIS PHASE
- ACCELERATED CONSTRUCTION
- TEMPORARY BUS STOP
- TEMPORARY PAVEMENT
- DIRECTION OF TRAFFIC (TCP/EXIST)
- VERTICAL PANELS
- TYPE III BARRICADE
- CONSTRUCTION PERIMETER FENCE
- LOW PROFILE WATER FILL BARRIER
- SIGN
- PLASTIC DRUMS

- NOTES:
- CONTRACTOR SHALL PROVIDE DRIVEWAY SIGNAGE AFFIXED TO THE TOP OF PLASTIC DRUMS AT ALL DRIVEWAY LOCATIONS.
 - VIA IS RESPONSIBLE FOR ALL TEMPORARY BUS STOPS AND RELATED SIGNING. ONCE VIA SETS UP TEMPORARY BUS STOPS CONTRACTOR SHALL ENSURE SIGNAGE REMAINS VISIBLE.
 - ELIMINATE PAVEMENT MARKINGS FOR CONTRACTOR INFO ONLY (NSPI.)

PRELIMINARY
FOR INTERIM REVIEW ONLY

By: MICHAEL G. RAMIREZ P.E. 133983
DATE 1/23/2023

CAMACHO-HERNANDEZ & ASSOCIATES, LLC
NOT FOR CONSTRUCTION, BIDDING, OR PERMIT PURPOSES

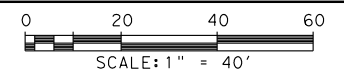

REV. NO.	DATE	DESCRIPTION	BY
CAMACHO-HERNANDEZ & ASSOCIATES, LLC 415 EMBASSY OAKS - SUITE 205 SAN ANTONIO, TX. 78216 OFFICE: (210) 341-6200 FAX: (210) 341-6300 FIRM NUMBER: F-8478			

Pape-Dawson ENGINEERS

SAN ANTONIO | AUSTIN | HOUSTON | FORT WORTH | DALLAS
2000 NW LOOP 410 | SAN ANTONIO, TX 78213 | 210.375.9000
TEXAS ENGINEERING FIRM #470 | TEXAS SURVEYING FIRM #10028800

CITY OF SAN ANTONIO
PUBLIC WORKS DEPARTMENT

DOLOROSA
TRAFFIC CONTROL PLAN
PHASE 1 STEP 3

STA 19+00 TO STA 27+00

SHEET 2 OF 6

FOR CONTRACTORS INFORMATION:
-BARRIER TO REMAIN IN EXISTING LOCATION: 180 LF
-BARRIER TO BE RELOCATED FROM PREVIOUS STEP: 0 LF
ALL BARRIER REMOVAL/RELOCATION SHALL BE SUBSIDIARY TO INSTALLATION COST OF WATER BARRIER. (NSPI)

DESIGN	CHECKED	DRAWN	PROJECT NO.	SUBMITTAL	SHEET NO.
MGR	JH	HR	23-03763	70%	53

Plotted on: 1/23/2023

Design File name: K:\COSA Dolores\TCP\Dolores\TCP_P1S3_03.dgn

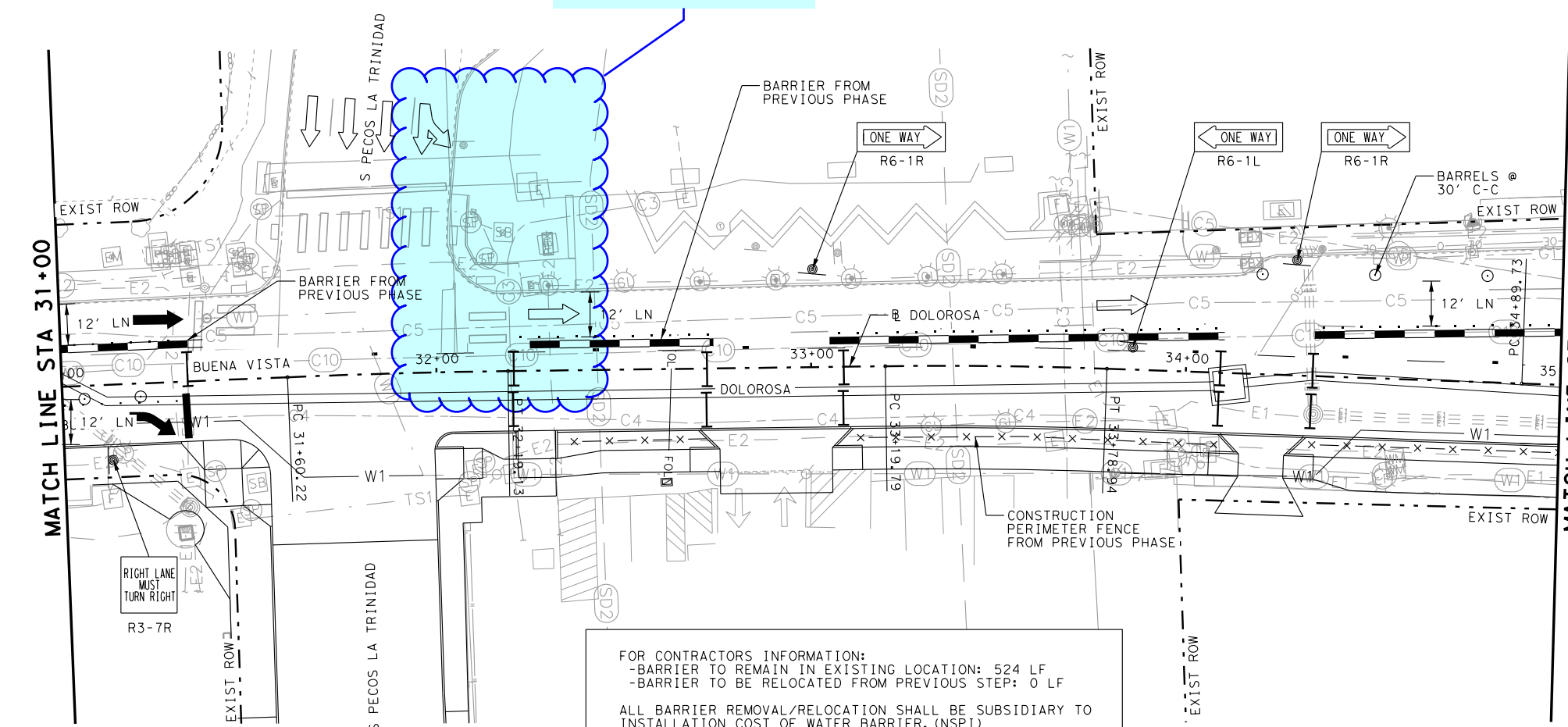
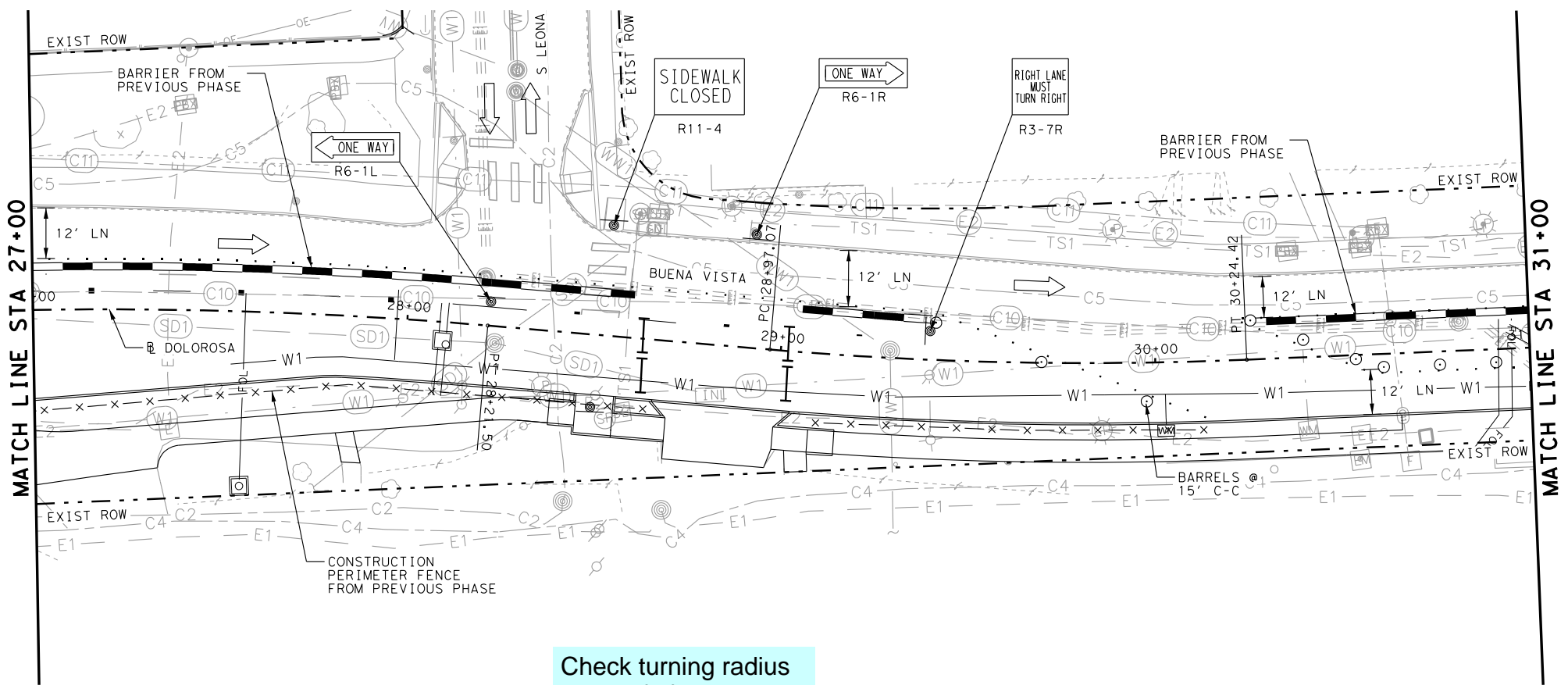

Check turning radius and shift if needed.

FOR CONTRACTORS INFORMATION:
 -BARRIER TO REMAIN IN EXISTING LOCATION: 524 LF
 -BARRIER TO BE RELOCATED FROM PREVIOUS STEP: 0 LF
 ALL BARRIER REMOVAL/RELOCATION SHALL BE SUBSIDIARY TO INSTALLATION COST OF WATER BARRIER. (NSPI)

ITEM	DESCRIPTION	UNIT	QTY
540.7	CONSTRUCTION PERIMETER FENCE	LF	-
5000	WATER FILLED BARRIER	LF	-
0508-6001	CONSTRUCTING DETOURS	SY	-
0662-6063	WK ZN PAV MRK REMOV (W)4" (SLD)	LF	-
0662-6071	WK ZN PAV MRK REMOV (W)8" (SLD)	LF	-
0662-6075	WK ZN PAV MRK REMOV (W)24" (SLD)	LF	-
0667-6001	ELIM EXT PAV MRK & MRKS (4")	LF	-
0667-6003	ELIM EXT PAV MRK & MRKS (8")	LF	-
0667-6007	ELIM EXT PAV MRK & MRKS (24")	LF	-
0667-6008	ELIM EXT PAV MRK & MRKS (ARROW)	EA	-

LEGEND

- CONSTRUCTION THIS PHASE
- ACCELERATED CONSTRUCTION
- TEMPORARY BUS STOP
- TEMPORARY PAVEMENT
- DIRECTION OF TRAFFIC (TCP/EXIST)
- VERTICAL PANELS
- TYPE III BARRICADE
- CONSTRUCTION PERIMETER FENCE
- LOW PROFILE WATER FILL BARRIER
- SIGN
- PLASTIC DRUMS

- NOTES:
- CONTRACTOR SHALL PROVIDE DRIVEWAY SIGNAGE AFFIXED TO THE TOP OF PLASTIC DRUMS AT ALL DRIVEWAY LOCATIONS.
 - VIA IS RESPONSIBLE FOR ALL TEMPORARY BUS STOPS AND RELATED SIGNING. ONCE VIA SETS UP TEMPORARY BUS STOPS CONTRACTOR SHALL ENSURE SIGNAGE REMAINS VISIBLE.
 - ELIMINATE PAVEMENT MARKINGS FOR CONTRACTOR INFO ONLY (NSPI.)

PRELIMINARY
 FOR INTERIM REVIEW ONLY

By: MICHAEL G. RAMIREZ P.E. 133983
 DATE 1/23/2023

CAMACHO-HERNANDEZ & ASSOCIATES, LLC
 NOT FOR CONSTRUCTION, BIDDING, OR PERMIT PURPOSES

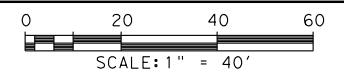

REV. NO.	DATE	DESCRIPTION	BY

CAMACHO-HERNANDEZ & ASSOCIATES, LLC
 415 EMBASSY OAKS - SUITE 205 SAN ANTONIO, TX. 78216
 OFFICE: (210) 341-6200 FAX: (210) 341-6300
 FIRM NUMBER: F-8478

PAPE-DAWSON ENGINEERS

SAN ANTONIO | AUSTIN | HOUSTON | FORT WORTH | DALLAS
 2000 NW LOOP 410 | SAN ANTONIO, TX 78213 | 210.375.9000
 TEXAS ENGINEERING FIRM #470 | TEXAS SURVEYING FIRM #10028800

CITY OF SAN ANTONIO
PUBLIC WORKS DEPARTMENT

DOLOROSA
TRAFFIC CONTROL PLAN
 PHASE 1 STEP 3

STA 27+00 TO STA 35+00

SHEET 3 OF 6

DESIGN	CHECKED	DRAWN	PROJECT NO.	SUBMITTAL	SHEET NO.
MGR	JH	HR	23-03763	70%	54

Plotted on: 1/23/2023

Design File name: K:\COSA Dolorosa\TCP\Dolorosa_TCP_P1S3_04.dgn

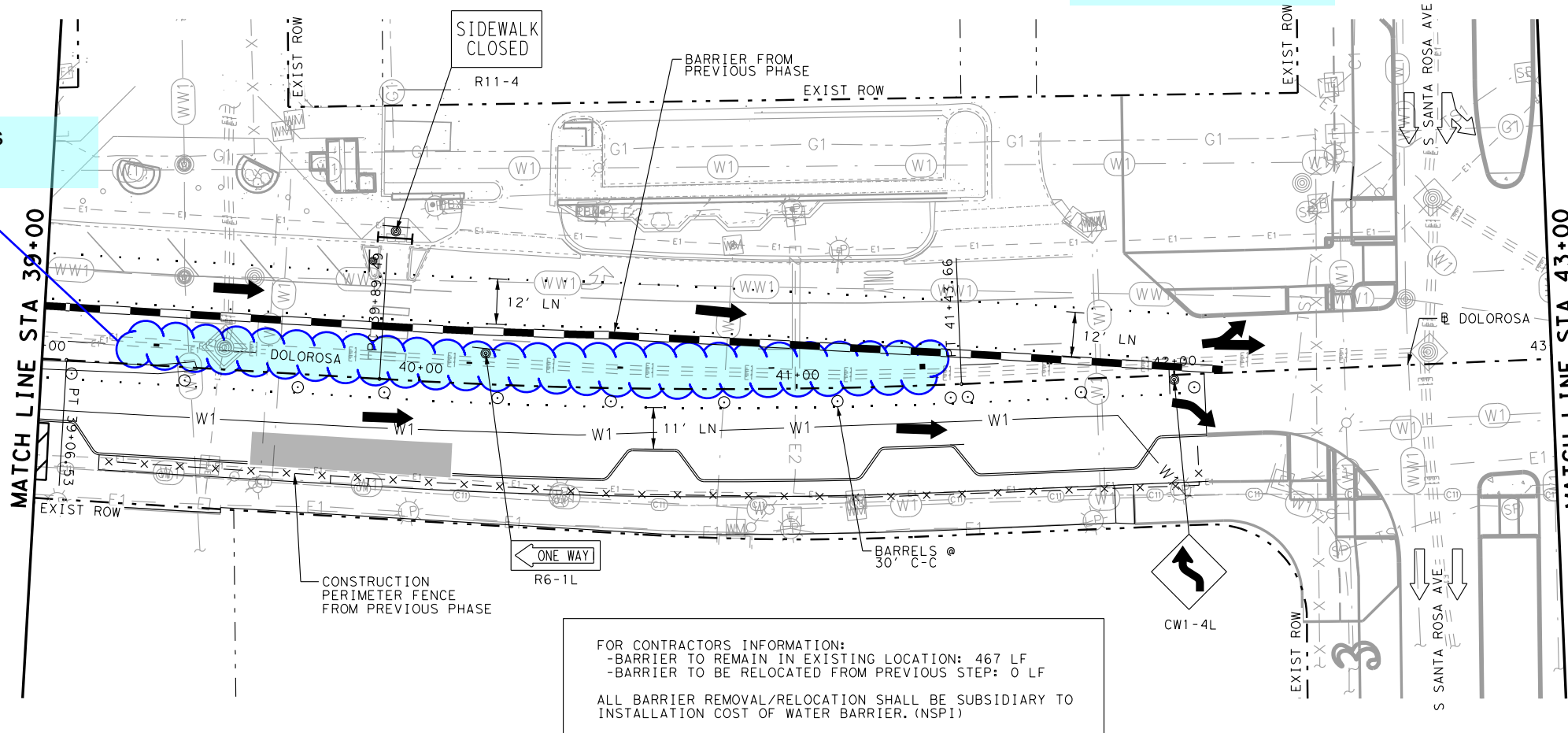
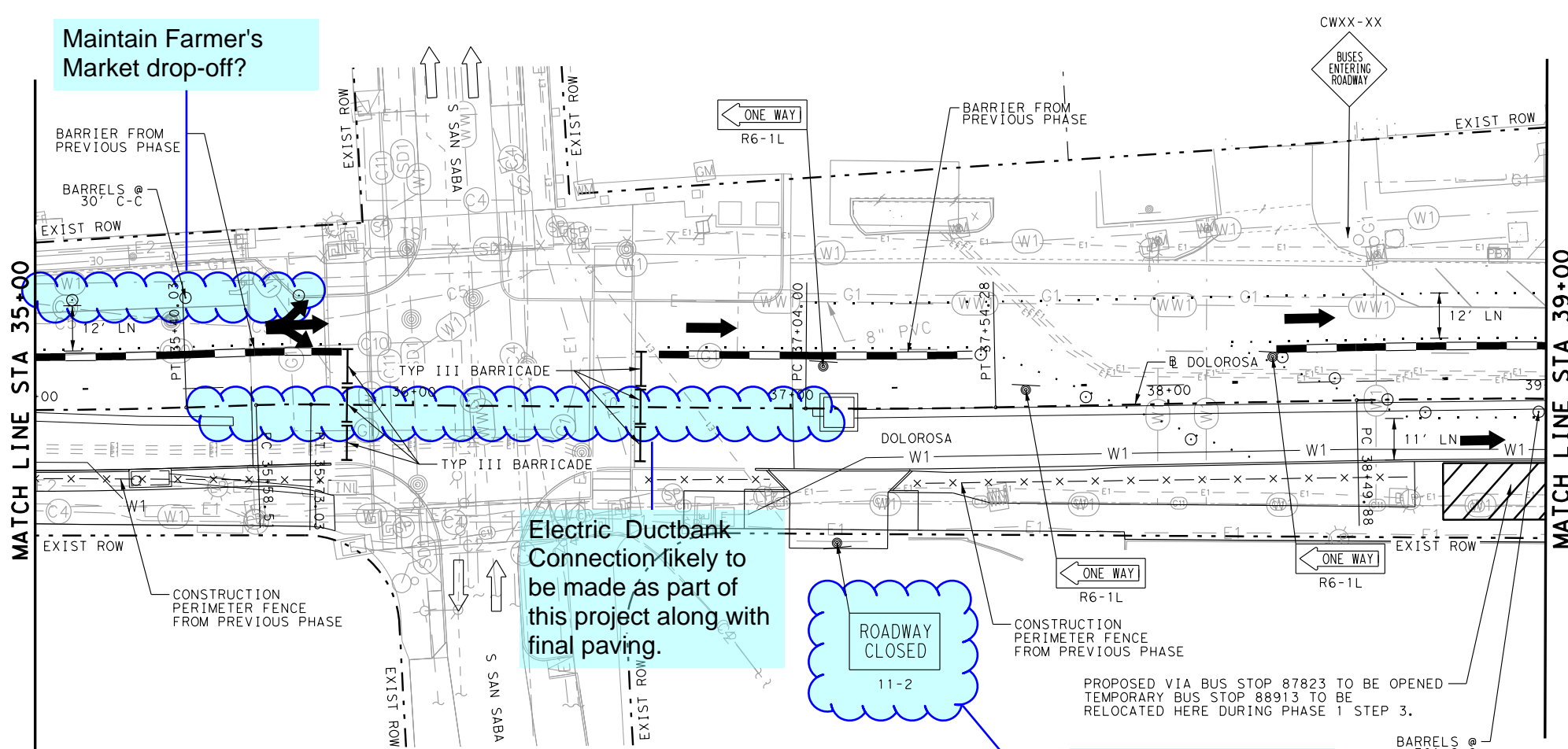

FOR CONTRACTORS INFORMATION:
 -BARRIER TO REMAIN IN EXISTING LOCATION: 467 LF
 -BARRIER TO BE RELOCATED FROM PREVIOUS STEP: 0 LF
 ALL BARRIER REMOVAL/RELOCATION SHALL BE SUBSIDIARY TO
 INSTALLATION COST OF WATER BARRIER. (NSP1)

ITEM	DESCRIPTION	UNIT	QTY
540.7	CONSTRUCTION PERIMETER FENCE	LF	-
5000	WATER FILLED BARRIER	LF	-
0508-6001	CONSTRUCTING DETOURS	SY	-
0662-6063	WK ZN PAV MRK REMOV (W)4"(SLD)	LF	472
0662-6071	WK ZN PAV MRK REMOV (W)8"(SLD)	LF	-
0662-6075	WK ZN PAV MRK REMOV (W)24"(SLD)	LF	-
0667-6001	ELIM EXT PAV MRK & MRKS (4")	LF	-
0667-6003	ELIM EXT PAV MRK & MRKS (8")	LF	-
0667-6007	ELIM EXT PAV MRK & MRKS (24")	LF	-
0667-6008	ELIM EXT PAV MRK & MRKS (ARROW)	EA	-

LEGEND

- CONSTRUCTION THIS PHASE
- ACCELERATED CONSTRUCTION
- TEMPORARY BUS STOP
- TEMPORARY PAVEMENT
- DIRECTION OF TRAFFIC (TCP/EXIST)
- VERTICAL PANELS
- TYPE III BARRICADE
- CONSTRUCTION PERIMETER FENCE
- LOW PROFILE WATER FILL BARRIER
- SIGN
- PLASTIC DRUMS

- NOTES:
- CONTRACTOR SHALL PROVIDE DRIVEWAY SIGNAGE AFFIXED TO THE TOP OF PLASTIC DRUMS AT ALL DRIVEWAY LOCATIONS.
 - VIA IS RESPONSIBLE FOR ALL TEMPORARY BUS STOPS AND RELATED SIGNING. ONCE VIA SETS UP TEMPORARY BUS STOPS CONTRACTOR SHALL ENSURE SIGNAGE REMAINS VISIBLE.
 - ELIMINATE PAVEMENT MARKINGS FOR CONTRACTOR INFO ONLY (NSP1.)

PRELIMINARY
 FOR INTERIM REVIEW ONLY
 By: MICHAEL G. RAMIREZ P.E. 133983
 DATE 1/23/2023
CAMACHO-HERNANDEZ & ASSOCIATES, LLC
 NOT FOR CONSTRUCTION, BIDDING, OR PERMIT PURPOSES

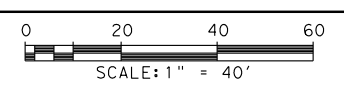

REV. NO.	DATE	DESCRIPTION	BY
CAMACHO-HERNANDEZ & ASSOCIATES, LLC 415 EMBASSY OAKS - SUITE 205 SAN ANTONIO, TX. 78216 OFFICE: (210) 341-6200 FAX: (210) 341-6300 FIRM NUMBER: F-8478			

PAPE-DAWSON ENGINEERS
 SAN ANTONIO | AUSTIN | HOUSTON | FORT WORTH | DALLAS
 2000 NW LOOP 410 | SAN ANTONIO, TX 78213 | 210.375.9000
 TEXAS ENGINEERING FIRM #470 | TEXAS SURVEYING FIRM #10028800

CITY OF SAN ANTONIO
PUBLIC WORKS DEPARTMENT

DOLOROSA
TRAFFIC CONTROL PLAN
 PHASE 1 STEP 3

STA 35+00 TO STA 43+00

SHEET 4 OF 6

DESIGN	CHECKED	DRAWN	PROJECT NO.	SUBMITTAL	SHEET NO.
MGR	JH	HR	23-03763	70%	55

Plotted on: 1/23/2023

Design File name: K:\COSA Dolorosa\TCP\Dolorosa_TCP_P1S3_05.dgn

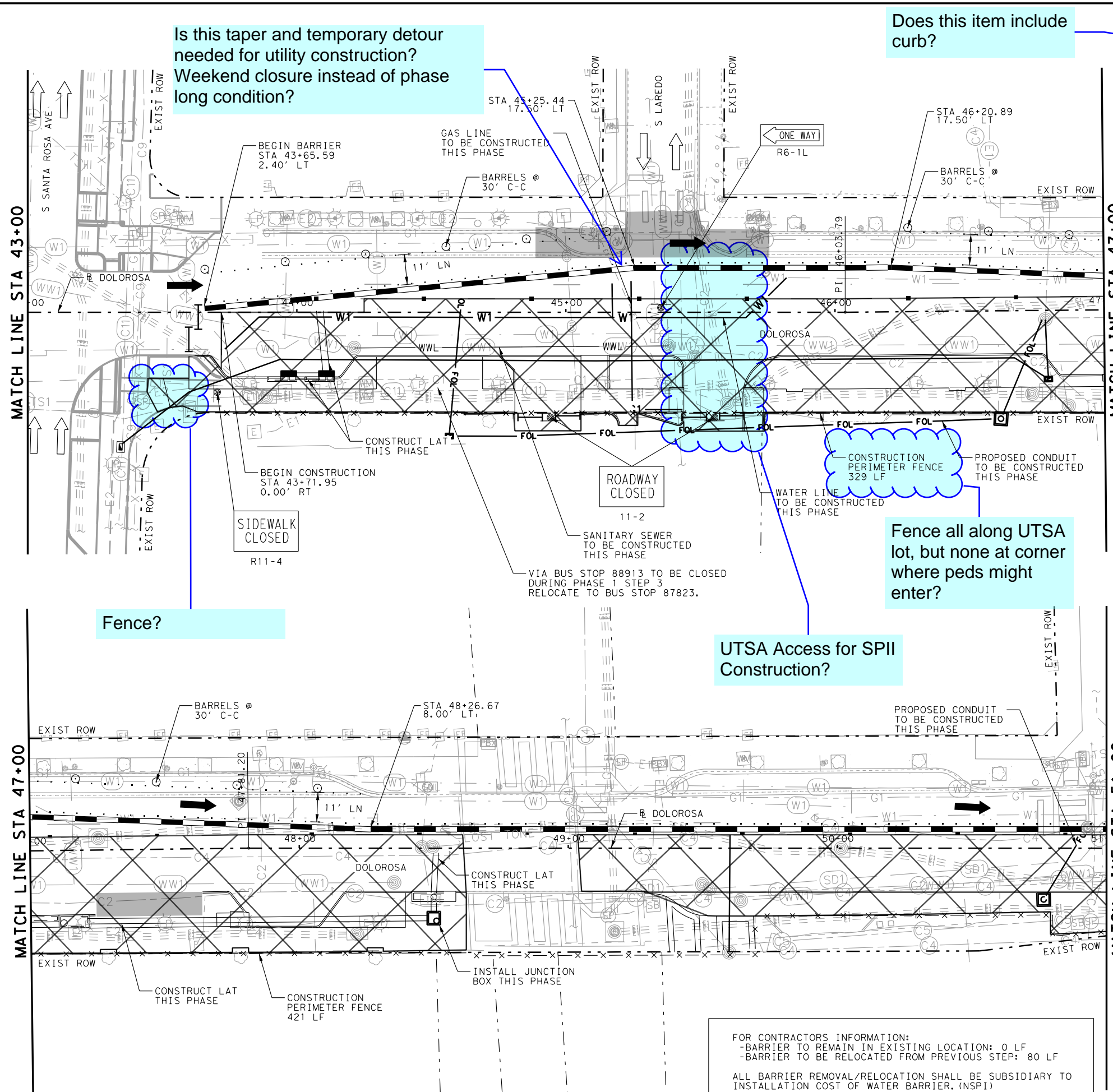

Is this taper and temporary detour needed for utility construction? Weekend closure instead of phase long condition?

Does this item include curb?

Fence?

UTSA Access for SPII Construction?

Fence all along UTSA lot, but none at corner where peds might enter?

ITEM	DESCRIPTION	UNIT	QTY
540.7	CONSTRUCTION PERIMETER FENCE	LF	750
5900	WATER FILLED BARRIER	LF	655
0508-6001	CONSTRUCTING DETOURS	SY	39
0662-6063	WK ZN PAV MRK REMOV (W)4" (SLD)	LF	1189
0662-6071	WK ZN PAV MRK REMOV (W)8" (SLD)	LF	-
0662-6075	WK ZN PAV MRK REMOV (W)24" (SLD)	LF	-
0667-6001	ELIM EXT PAV MRK & MRKS (4")	LF	149
0667-6003	ELIM EXT PAV MRK & MRKS (8")	LF	-
0667-6007	ELIM EXT PAV MRK & MRKS (24")	LF	-
0667-6008	ELIM EXT PAV MRK & MRKS (ARROW)	EA	-

LEGEND

- CONSTRUCTION THIS PHASE
- ACCELERATED CONSTRUCTION
- TEMPORARY BUS STOP
- TEMPORARY PAVEMENT
- DIRECTION OF TRAFFIC (TCP/EXIST)
- VERTICAL PANELS
- TYPE III BARRICADE
- CONSTRUCTION PERIMETER FENCE
- LOW PROFILE WATER FILL BARRIER
- SIGN
- PLASTIC DRUMS

NOTES:
 1. CONTRACTOR SHALL PROVIDE DRIVEWAY SIGNAGE AFFIXED TO THE TOP OF PLASTIC DRUMS AT ALL DRIVEWAY LOCATIONS.
 2. VIA IS RESPONSIBLE FOR ALL TEMPORARY BUS STOPS AND RELATED SIGNING. ONCE VIA SETS UP TEMPORARY BUS STOPS CONTRACTOR SHALL ENSURE SIGNAGE REMAINS VISIBLE.
 3. ELIMINATE PAVEMENT MARKINGS FOR CONTRACTOR INFO ONLY (NSPI.)

PRELIMINARY
 FOR INTERIM REVIEW ONLY
 By: MICHAEL G. RAMIREZ P.E. 133983
 DATE 1/23/2023
CAMACHO-HERNANDEZ & ASSOCIATES, LLC
 NOT FOR CONSTRUCTION, BIDDING, OR PERMIT PURPOSES



REV. NO.	DATE	DESCRIPTION	BY

CAMACHO-HERNANDEZ & ASSOCIATES, LLC
 415 EMBASSY OAKS - SUITE 205 SAN ANTONIO, TX. 78216
 OFFICE: (210) 341-6200 FAX: (210) 341-6300
 FIRM NUMBER: F-8478

PAPE-DAWSON ENGINEERS
 SAN ANTONIO | AUSTIN | HOUSTON | FORT WORTH | DALLAS
 2000 NW LOOP 410 | SAN ANTONIO, TX 78213 | 210.375.9000
 TEXAS ENGINEERING FIRM #470 | TEXAS SURVEYING FIRM #10028800

CITY OF SAN ANTONIO
PUBLIC WORKS DEPARTMENT

DOLOROSA
TRAFFIC CONTROL PLAN
 PHASE 1 STEP 3

STA 43+00 TO STA 51+00

SHEET 5 OF 6

DESIGN	CHECKED	DRAWN	PROJECT NO.	SUBMITTAL	SHEET NO.
MGR	JH	HR	23-03763	70%	56

FOR CONTRACTORS INFORMATION:
 -BARRIER TO REMAIN IN EXISTING LOCATION: 0 LF
 -BARRIER TO BE RELOCATED FROM PREVIOUS STEP: 80 LF
 ALL BARRIER REMOVAL/RELOCATION SHALL BE SUBSIDIARY TO INSTALLATION COST OF WATER BARRIER. (NSPI)

NOTE:

TCP FROM STA 25+16 TO STA 50+50 TO REMAIN THE SAME AS PREVIOUS STEP.

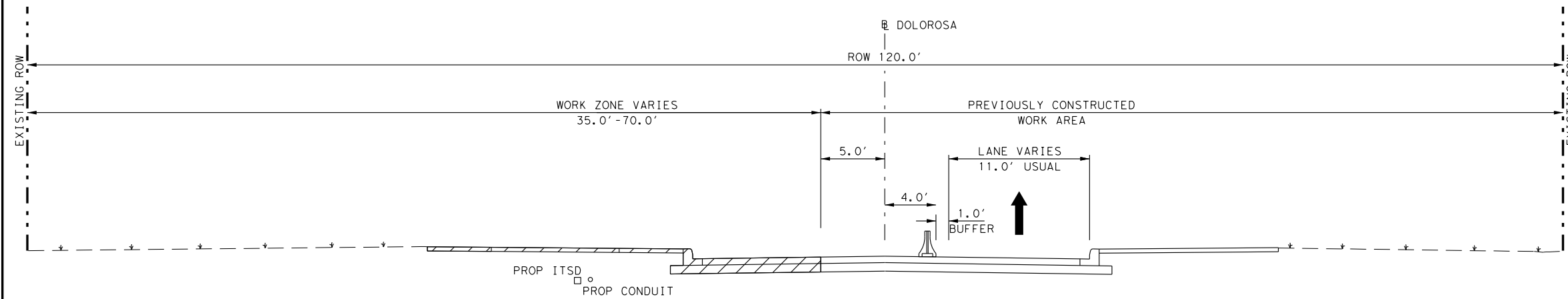



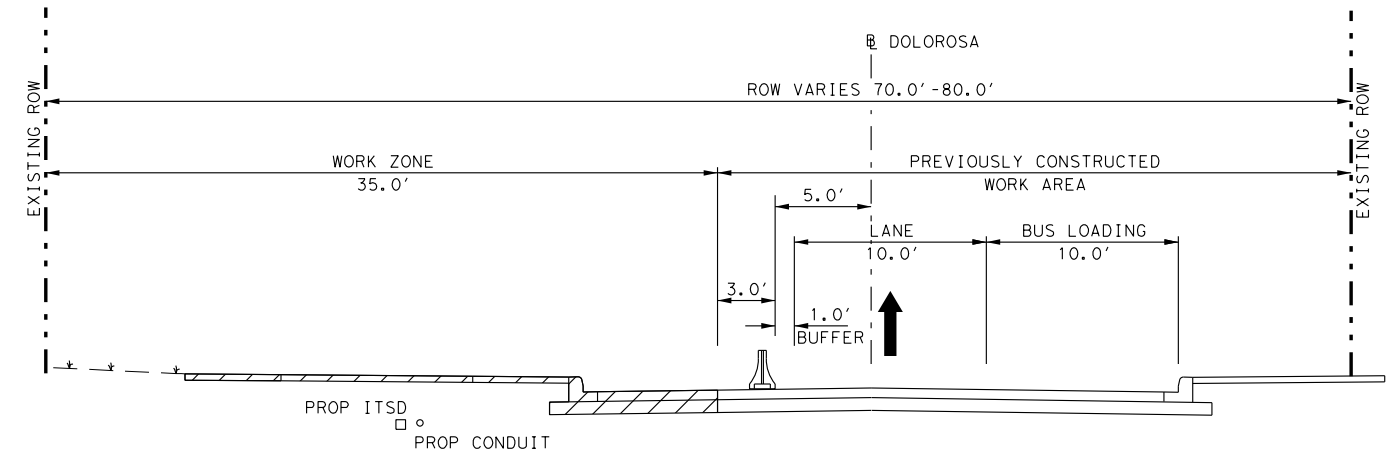

PHASE 2
STA 25+16.00 TO STA 29+50.00

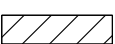
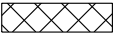

PHASE 2
STA 29+50.00 TO STA 31+32.50

LEGEND

- EXISTING ROADWAY
- PROPOSED ROADWAY
-  WORK AREA
-  ACCELERATED WORK AREA
-  TEMPORARY PAVEMENT
-  LOW PROFILE WATER FILL BARRIER
-  VERTICAL PANELS

PRELIMINARY
FOR INTERIM REVIEW ONLY

By: MICHAEL G. RAMIREZ P.E. 133983
DATE 1/23/2023

CAMACHO-HERNANDEZ & ASSOCIATES, LLC
NOT FOR CONSTRUCTION, BIDDING, OR PERMIT PURPOSES

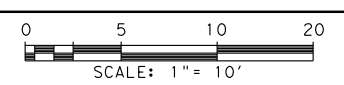

REV. NO.	DATE	DESCRIPTION	BY

CAMACHO-HERNANDEZ & ASSOCIATES, LLC
415 EMBASSY OAKS - SUITE 205 SAN ANTONIO, TX. 78216
OFFICE: (210) 341-6200 FAX: (210) 341-6300
FIRM NUMBER: F-8478

Pape-Dawson ENGINEERS

SAN ANTONIO | AUSTIN | HOUSTON | FORT WORTH | DALLAS
2000 NW LOOP 410 | SAN ANTONIO, TX 78213 | 210.375.9000
TEXAS ENGINEERING FIRM #470 | TEXAS SURVEYING FIRM #10028800

 **CITY OF SAN ANTONIO PUBLIC WORKS DEPARTMENT**

DOLOROSA
TRAFFIC CONTROL PLAN
TYPICAL SECTIONS

PHASE 2

SHEET 1 OF 4

DESIGN	CHECKED	DRAWN	PROJECT NO.	SUBMITTAL	SHEET NO.
MGR	JH	HR	23-03763	70%	58

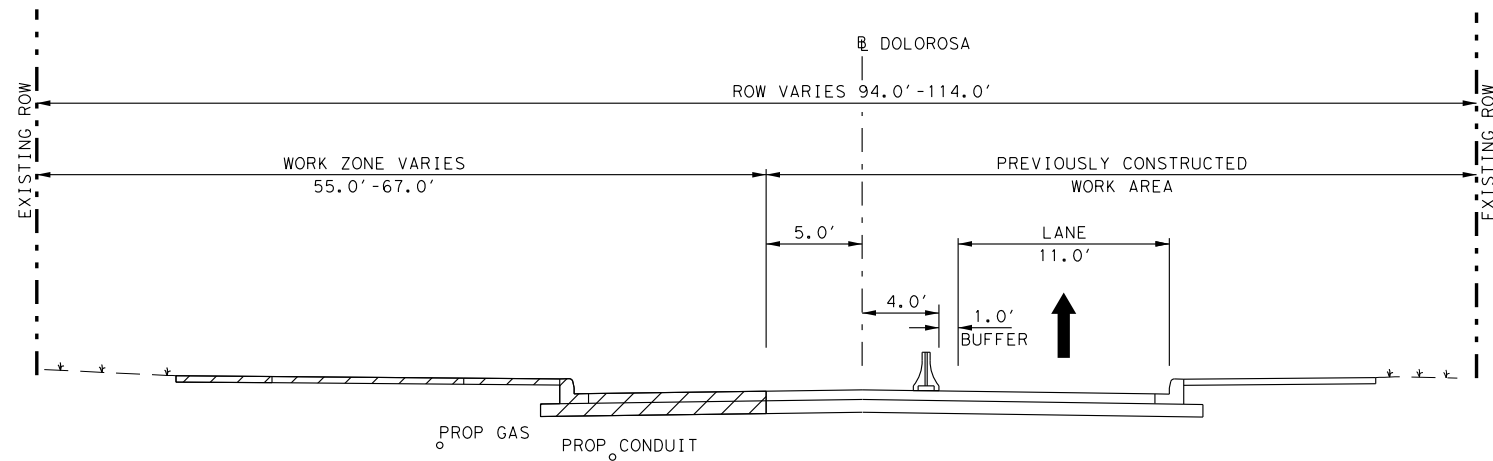

PHASE 2
STA 36+90.00 TO STA 39+00.00

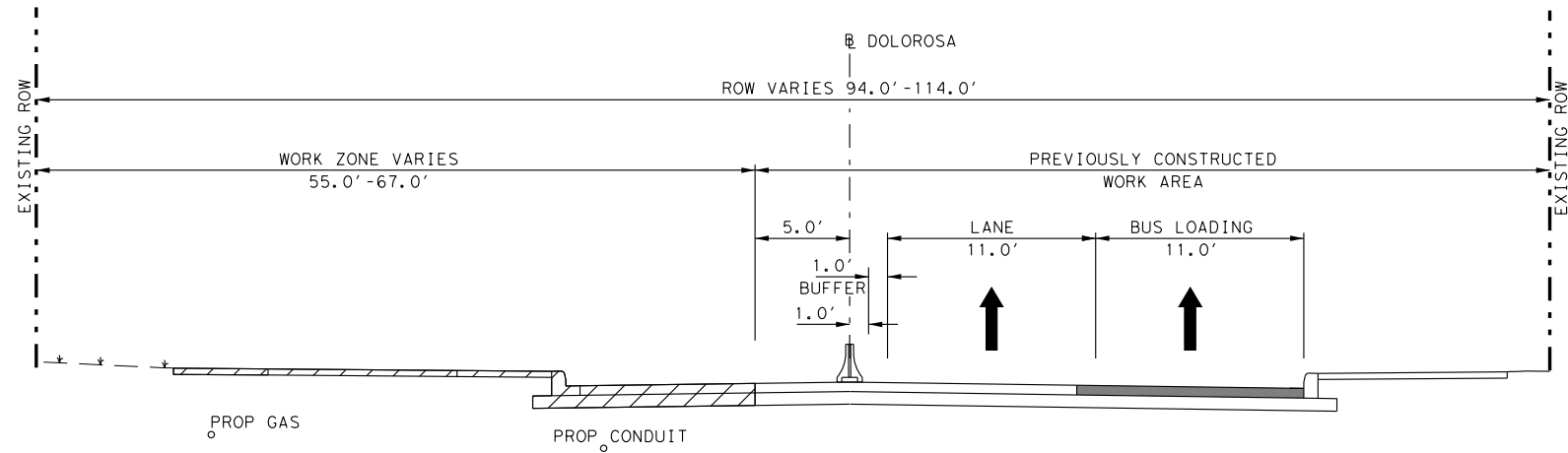

PHASE 2
STA 39+00.00 TO STA 42+00.00

LEGEND

- EXISTING ROADWAY
- PROPOSED ROADWAY
- WORK AREA
- ACCELERATED WORK AREA
- TEMPORARY PAVEMENT
- LOW PROFILE WATER FILL BARRIER
- VERTICAL PANELS

PRELIMINARY

FOR INTERIM REVIEW ONLY

By: MICHAEL G. RAMIREZ P.E. 133983

DATE 1/23/2023

CAMACHO-HERNANDEZ & ASSOCIATES, LLC

NOT FOR CONSTRUCTION, BIDDING, OR PERMIT PURPOSES

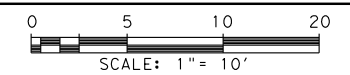

REV. NO.	DATE	DESCRIPTION	BY
CAMACHO-HERNANDEZ & ASSOCIATES, LLC 415 EMBASSY OAKS - SUITE 205 SAN ANTONIO, TX. 78216 OFFICE: (210) 341-6200 FAX: (210) 341-6300 FIRM NUMBER: F-8478			



SAN ANTONIO | AUSTIN | HOUSTON | FORT WORTH | DALLAS
 2000 NW LOOP 410 | SAN ANTONIO, TX 78213 | 210.375.9000
 TEXAS ENGINEERING FIRM #470 | TEXAS SURVEYING FIRM #10028800



DOLOROSA
TRAFFIC CONTROL PLAN
 TYPICAL SECTIONS

PHASE 2

SHEET 2 OF 4

DESIGN	CHECKED	DRAWN	PROJECT NO.	SUBMITTAL	SHEET NO.
MGR	JH	HR	23-03763	70%	59

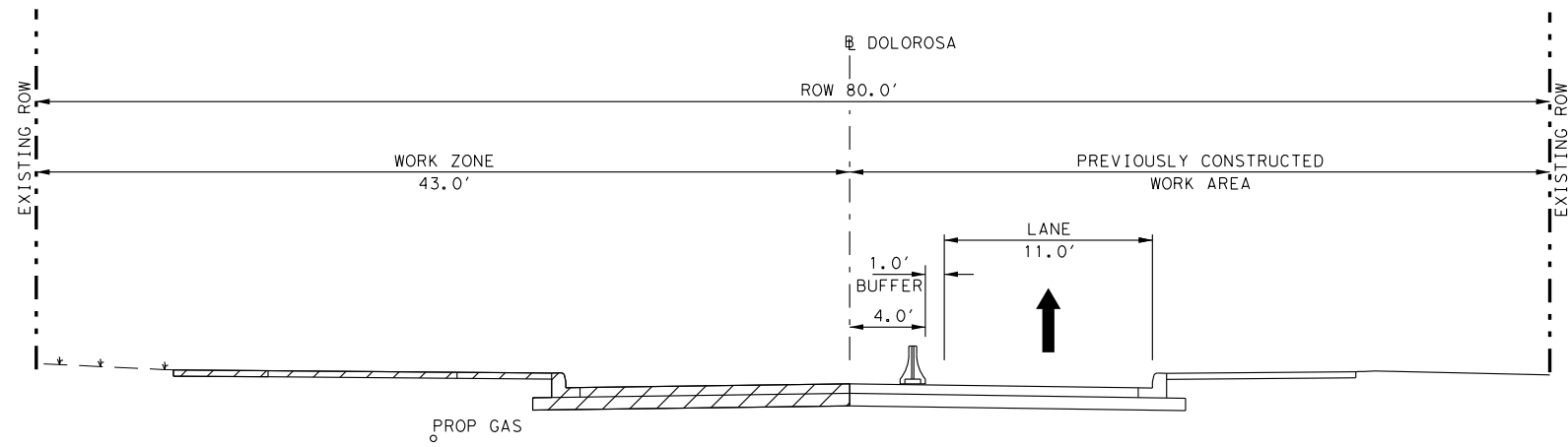

PHASE 2
STA 42+00.00 TO STA 47+00.00

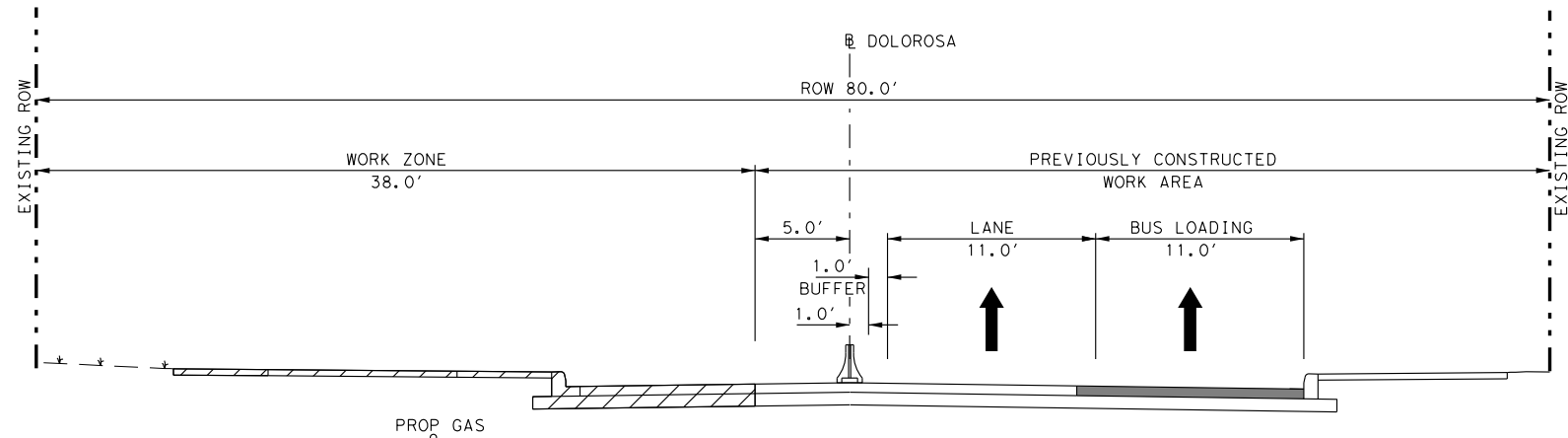

PHASE 2
STA 47+00.00 TO STA 48+00.00

LEGEND

- EXISTING ROADWAY
- PROPOSED ROADWAY
- WORK AREA
- ACCELERATED WORK AREA
- TEMPORARY PAVEMENT
- LOW PROFILE WATER FILL BARRIER
- VERTICAL PANELS

PRELIMINARY
FOR INTERIM REVIEW ONLY

By: MICHAEL G. RAMIREZ P.E. 133983
DATE 1/23/2023

CAMACHO-HERNANDEZ & ASSOCIATES, LLC
NOT FOR CONSTRUCTION, BIDDING, OR PERMIT PURPOSES

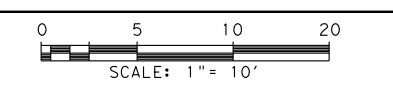

REV. NO.	DATE	DESCRIPTION	BY

CAMACHO-HERNANDEZ & ASSOCIATES, LLC
415 EMBASSY OAKS - SUITE 205 SAN ANTONIO, TX. 78216
OFFICE: (210) 341-6200 FAX: (210) 341-6300
FIRM NUMBER: F-8478

PAPE-DAWSON ENGINEERS

SAN ANTONIO | AUSTIN | HOUSTON | FORT WORTH | DALLAS
2000 NW LOOP 410 | SAN ANTONIO, TX 78213 | 210.375.9000
TEXAS ENGINEERING FIRM #470 | TEXAS SURVEYING FIRM #10028800

CITY OF SAN ANTONIO
PUBLIC WORKS DEPARTMENT

DOLOROSA
TRAFFIC CONTROL PLAN
TYPICAL SECTIONS

PHASE 2

SHEET 3 OF 4

DESIGN	CHECKED	DRAWN	PROJECT NO.	SUBMITTAL	SHEET NO.
MGR	JH	HR	23-03763	70%	60

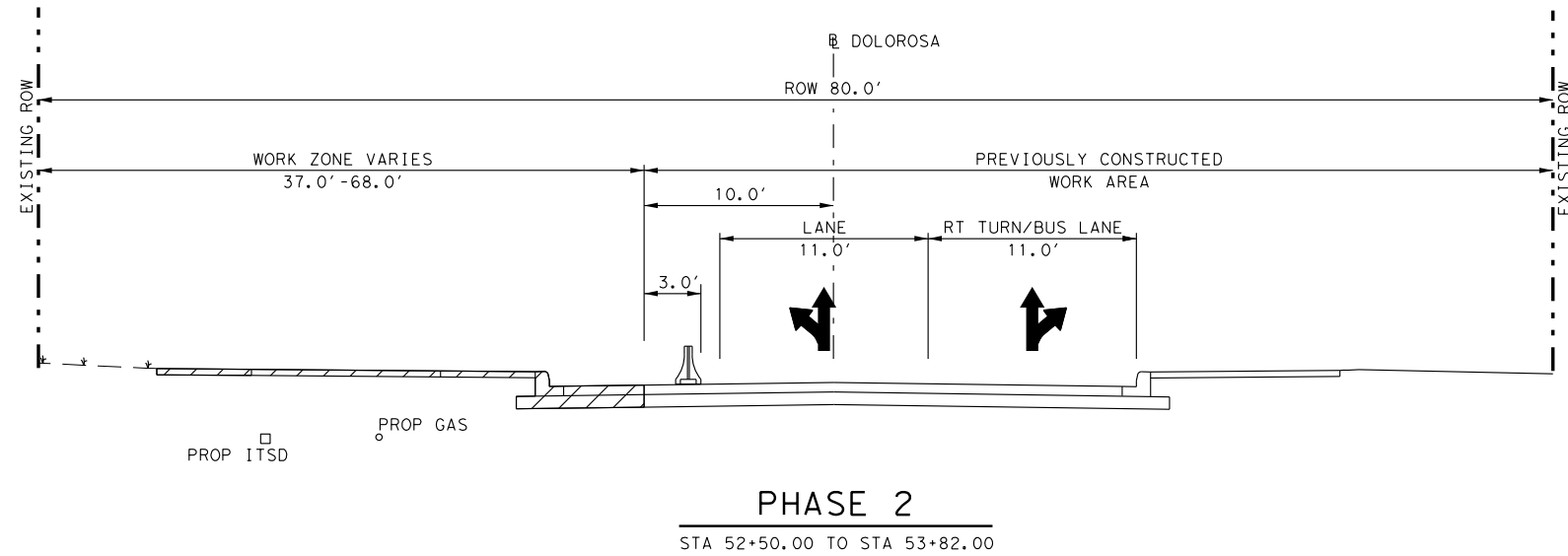
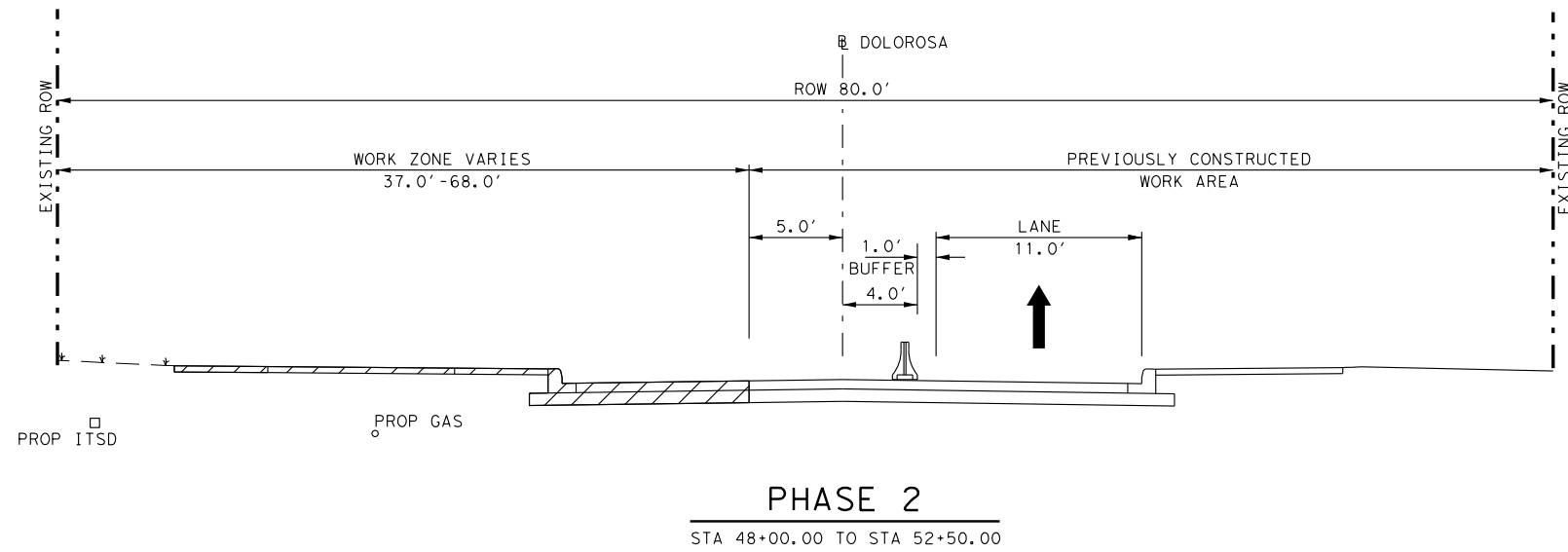

LEGEND

- EXISTING ROADWAY
- PROPOSED ROADWAY
- WORK AREA
- ACCELERATED WORK AREA
- TEMPORARY PAVEMENT
- LOW PROFILE WATER FILL BARRIER
- VERTICAL PANELS

PRELIMINARY
FOR INTERIM REVIEW ONLY

By: MICHAEL G. RAMIREZ P.E. 133983
DATE 1/23/2023

CAMACHO-HERNANDEZ & ASSOCIATES, LLC
NOT FOR CONSTRUCTION, BIDDING, OR PERMIT PURPOSES

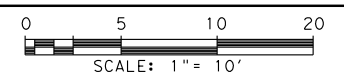

REV. NO.	DATE	DESCRIPTION	BY

CAMACHO-HERNANDEZ & ASSOCIATES, LLC
415 EMBASSY OAKS - SUITE 205 SAN ANTONIO, TX. 78216
OFFICE: (210) 341-6200 FAX: (210) 341-6300
FIRM NUMBER: F-8478

PAPE-DAWSON ENGINEERS

SAN ANTONIO | AUSTIN | HOUSTON | FORT WORTH | DALLAS
2000 NW LOOP 410 | SAN ANTONIO, TX 78213 | 210.375.9000
TEXAS ENGINEERING FIRM #470 | TEXAS SURVEYING FIRM #10028800

CITY OF SAN ANTONIO
PUBLIC WORKS DEPARTMENT

DOLOROSA
TRAFFIC CONTROL PLAN
TYPICAL SECTIONS

PHASE 2

SHEET 4 OF 4

DESIGN	CHECKED	DRAWN	PROJECT NO.	SUBMITTAL	SHEET NO.
MGR	JH	HR	23-03763	70%	61

Need to assess and addressed impacted businesses. Business access signs will be needed. Impacts should be minimized Full closure of Leona intersection should be minimized and opened to at least 1 way traffic as soon as practicable.

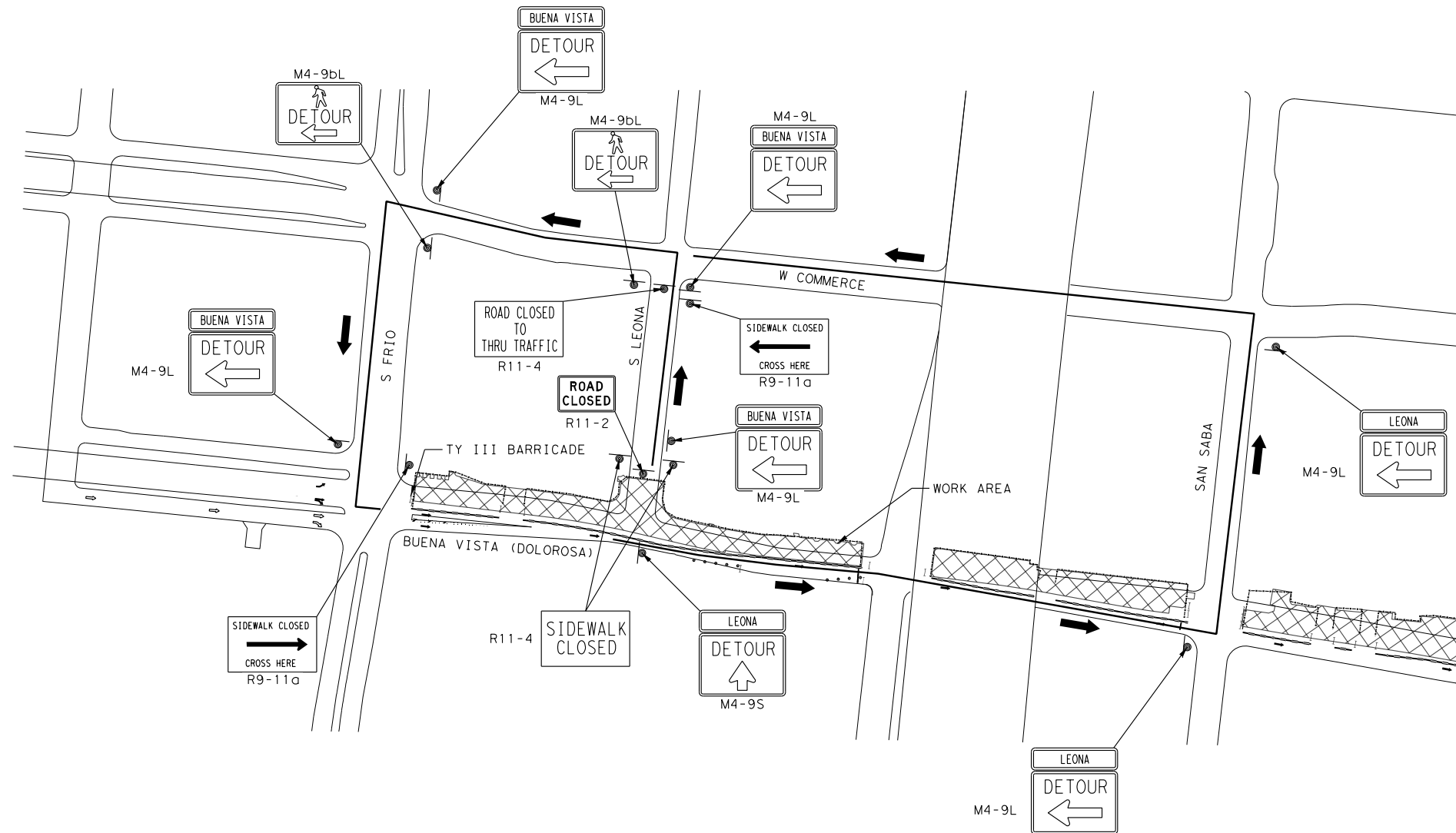

Plotted on: 1/23/2023

Design File name: K:\COSA Dolorosa\TCP\Dolorosa_TCP_DETOUR02.dgn

PRELIMINARY
FOR INTERIM REVIEW ONLY
 By: MICHAEL G. RAMIREZ P.E. 133983
 DATE 1/23/2023
CAMACHO-HERNANDEZ & ASSOCIATES, LLC
 NOT FOR CONSTRUCTION, BIDDING, OR PERMIT PURPOSES

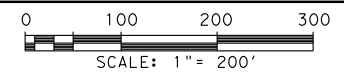

REV. NO.	DATE	DESCRIPTION	BY

CAMACHO-HERNANDEZ & ASSOCIATES, LLC
 415 EMBASSY OAKS - SUITE 205 SAN ANTONIO, TX. 78216
 OFFICE: (210) 341-6200 FAX: (210) 341-6300
 FIRM NUMBER: F-8478



PAPE-DAWSON ENGINEERS
 SAN ANTONIO | AUSTIN | HOUSTON | FORT WORTH | DALLAS
 2000 NW LOOP 410 | SAN ANTONIO, TX 78213 | 210.375.9000
 TEXAS ENGINEERING FIRM #470 | TEXAS SURVEYING FIRM #10028800



CITY OF SAN ANTONIO
PUBLIC WORKS DEPARTMENT
 DOLOROSA
TRAFFIC CONTROL PLAN
DETOUR LAYOUT

PHASE 2 - S LEONA

SHEET 1 OF 2

DESIGN	CHECKED	DRAWN	PROJECT NO.	SUBMITTAL	SHEET NO.
MGR	JH	HR	23-03763	70%	62

Plotted on: 1/23/2023

Design File name: K:\COSA Dolorosa\TCP\Dolorosa_TCP_DETOUR03.dgn

N

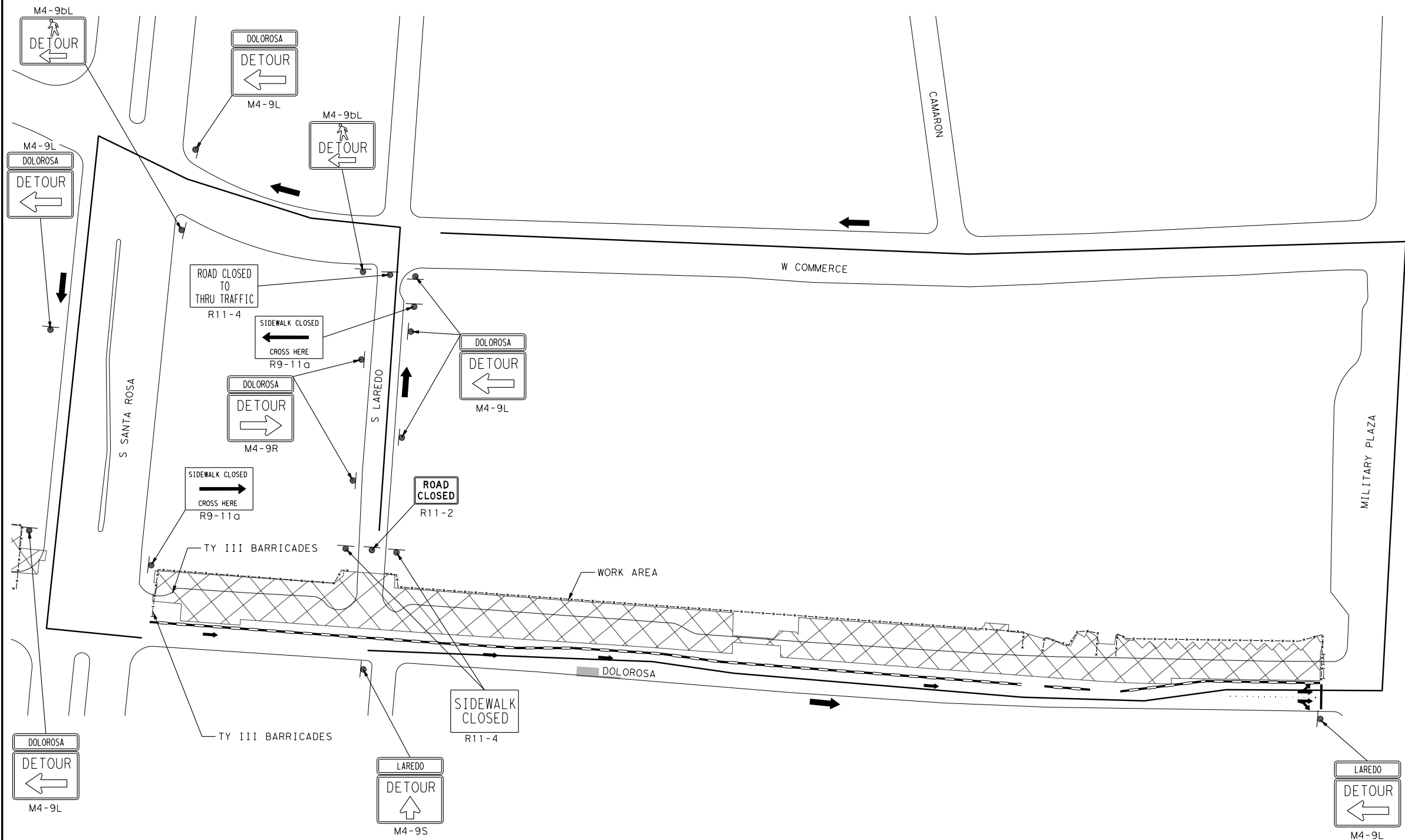

PRELIMINARY
 FOR INTERIM REVIEW ONLY
 By: MICHAEL G. RAMIREZ P.E. 133983
 DATE 1/23/2023
CAMACHO-HERNANDEZ & ASSOCIATES, LLC
 NOT FOR CONSTRUCTION, BIDDING, OR PERMIT PURPOSES

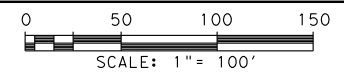

REV. NO.	DATE	DESCRIPTION	BY

CAMACHO-HERNANDEZ & ASSOCIATES, LLC
 415 EMBASSY OAKS - SUITE 205 SAN ANTONIO, TX. 78216
 OFFICE: (210) 341-6200 FAX: (210) 341-6300
 FIRM NUMBER: F-8478

Pape-Dawson ENGINEERS
 SAN ANTONIO | AUSTIN | HOUSTON | FORT WORTH | DALLAS
 2000 NW LOOP 410 | SAN ANTONIO, TX 78213 | 210.375.9000
 TEXAS ENGINEERING FIRM #470 | TEXAS SURVEYING FIRM #10028800

CITY OF SAN ANTONIO
PUBLIC WORKS DEPARTMENT

DOLOROSA
**TRAFFIC CONTROL PLAN
 DETOUR LAYOUT**

PHASE 2 - S LAREDO

SHEET 2 OF 2

DESIGN	CHECKED	DRAWN	PROJECT NO.	SUBMITTAL	SHEET NO.
MGR	JH	HR	23-03763	70%	63

Plotted on: 1/23/2023

Design File name: K:\COSA Dolorosa\TCP\Dolorosa_TCP_P2_01.dgn

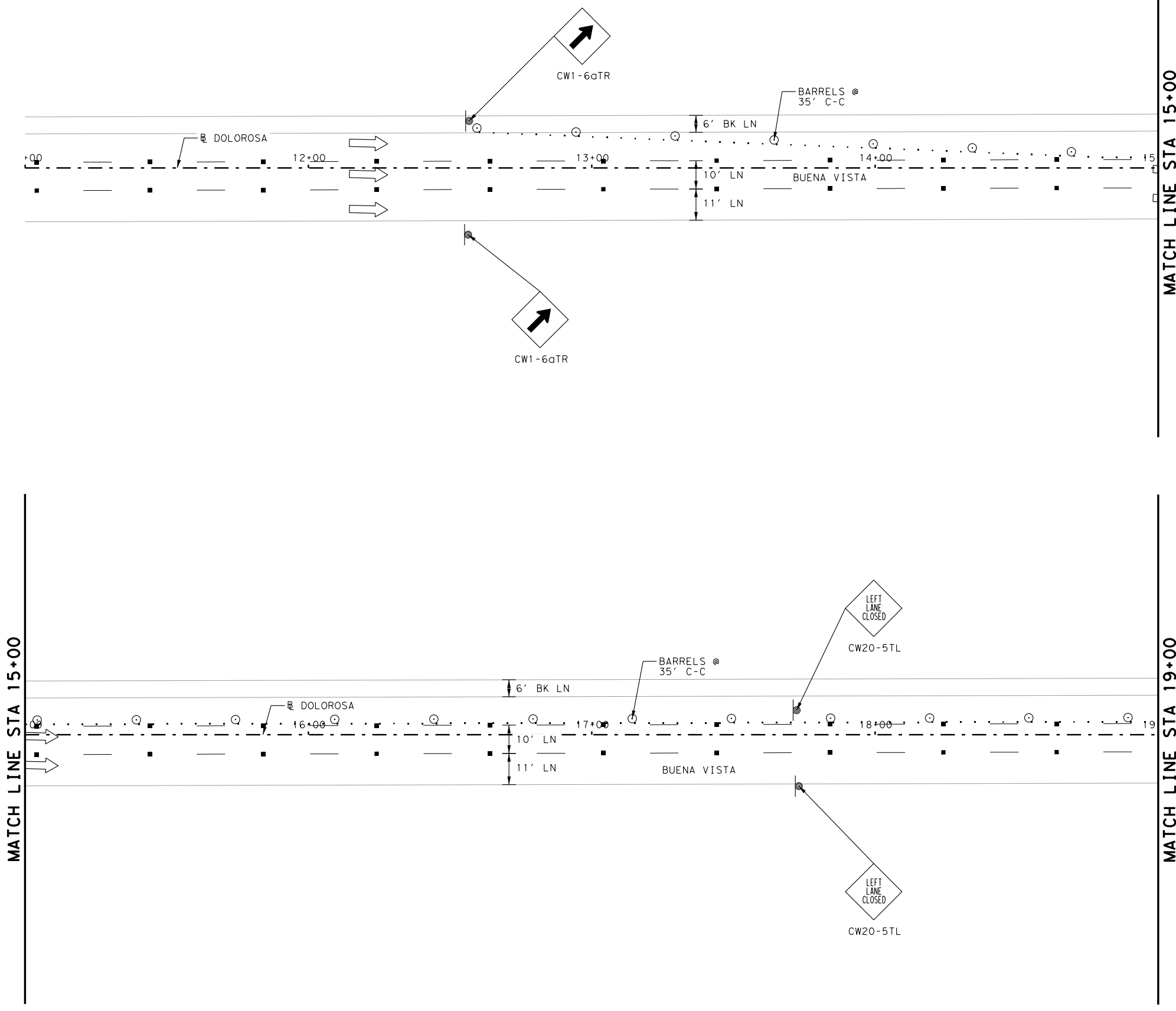

ITEM	DESCRIPTION	UNIT	QTY
540.7	CONSTRUCTION PERIMETER FENCE	LF	-
5000	WATER FILLED BARRIER	LF	-
0508-6001	CONSTRUCTING DETOURS	SY	-
0662-6063	WK ZN PAV MRK REMOV (W)4" (SLD)	LF	642
0662-6071	WK ZN PAV MRK REMOV (W)8" (SLD)	LF	-
0662-6075	WK ZN PAV MRK REMOV (W)24" (SLD)	LF	-
0667-6001	ELIM EXT PAV MRK & MRKS (4")	LF	161
0667-6003	ELIM EXT PAV MRK & MRKS (8")	LF	-
0667-6007	ELIM EXT PAV MRK & MRKS (24")	LF	-
0667-6008	ELIM EXT PAV MRK & MRKS (ARROW)	EA	-

LEGEND

- CONSTRUCTION THIS PHASE
- ACCELERATED CONSTRUCTION
- TEMPORARY BUS STOP
- TEMPORARY PAVEMENT
- DIRECTION OF TRAFFIC (TCP/EXIST)
- VERTICAL PANELS
- TYPE III BARRICADE
- CONSTRUCTION PERIMETER FENCE
- LOW PROFILE WATER FILL BARRIER
- SIGN
- PLASTIC DRUMS

NOTES:
 1. CONTRACTOR SHALL PROVIDE DRIVEWAY SIGNAGE AFFIXED TO THE TOP OF PLASTIC DRUMS AT ALL DRIVEWAY LOCATIONS.
 2. VIA IS RESPONSIBLE FOR ALL TEMPORARY BUS STOPS AND RELATED SIGNING. ONCE VIA SETS UP TEMPORARY BUS STOPS CONTRACTOR SHALL ENSURE SIGNAGE REMAINS VISIBLE.
 3. ELIMINATE PAVEMENT MARKINGS FOR CONTRACTOR INFO ONLY (NSPI.)

PRELIMINARY
 FOR INTERIM REVIEW ONLY
 By: MICHAEL G. RAMIREZ P.E. 133983
 DATE 1/23/2023
CAMACHO-HERNANDEZ & ASSOCIATES, LLC
 NOT FOR CONSTRUCTION, BIDDING, OR PERMIT PURPOSES

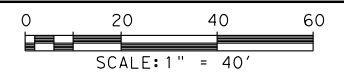

REV. NO.	DATE	DESCRIPTION	BY
CAMACHO-HERNANDEZ & ASSOCIATES, LLC 415 EMBASSY OAKS - SUITE 205 SAN ANTONIO, TX. 78216 OFFICE: (210) 341-6200 FAX: (210) 341-6300 FIRM NUMBER: F-8478			

PAPE-DAWSON ENGINEERS
 SAN ANTONIO | AUSTIN | HOUSTON | FORT WORTH | DALLAS
 2000 NW LOOP 410 | SAN ANTONIO, TX 78213 | 210.375.9000
 TEXAS ENGINEERING FIRM #470 | TEXAS SURVEYING FIRM #10028800

CITY OF SAN ANTONIO
PUBLIC WORKS DEPARTMENT

DOLOROSA
TRAFFIC CONTROL PLAN
 PHASE 2

BEGIN TO STA 19+00

SHEET 1 OF 6

DESIGN	CHECKED	DRAWN	PROJECT NO.	SUBMITTAL	SHEET NO.
MGR	JH	HR	23-03763	70%	64

Plotted on: 1/23/2023

Design File name: K:\COSA Dolorosa\TCP\Dolorosa_TCP_P2_02.dgn

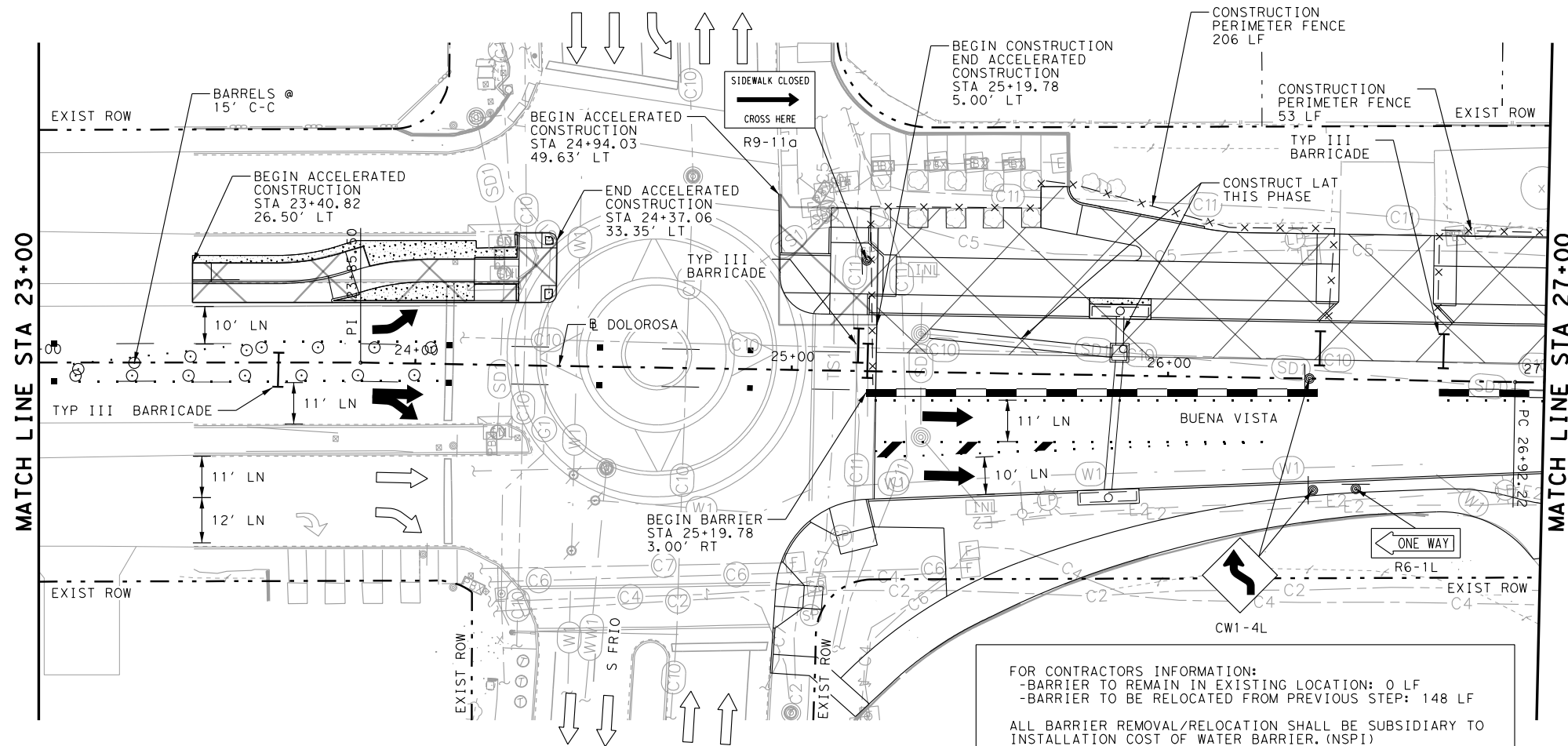
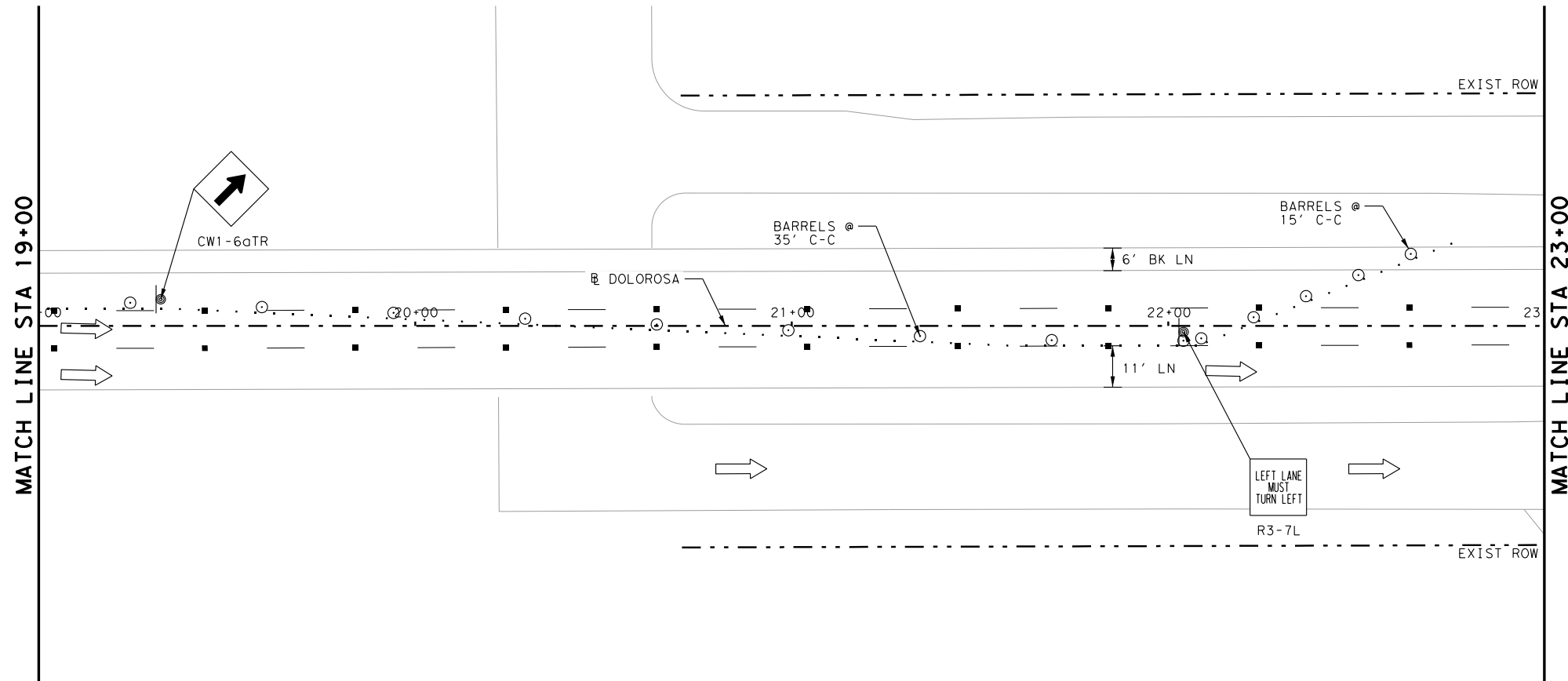

FOR CONTRACTORS INFORMATION:
 -BARRIER TO REMAIN IN EXISTING LOCATION: 0 LF
 -BARRIER TO BE RELOCATED FROM PREVIOUS STEP: 148 LF
 ALL BARRIER REMOVAL/RELOCATION SHALL BE SUBSIDIARY TO
 INSTALLATION COST OF WATER BARRIER. (NSPI)

ITEM	DESCRIPTION	UNIT	QTY
540.7	CONSTRUCTION PERIMETER FENCE	LF	259
5000	WATER FILLED BARRIER	LF	-
0508-6001	CONSTRUCTING DETOURS	SY	-
0662-6063	WK ZN PAV MRK REMOV (W)4" (SLD)	LF	731
0662-6071	WK ZN PAV MRK REMOV (W)8" (SLD)	LF	211
0662-6075	WK ZN PAV MRK REMOV (W)24" (SLD)	LF	14
0667-6001	ELIM EXT PAV MRK & MRKS (4")	LF	8
0667-6003	ELIM EXT PAV MRK & MRKS (8")	LF	-
0667-6007	ELIM EXT PAV MRK & MRKS (24")	LF	-
0667-6008	ELIM EXT PAV MRK & MRKS (ARROW)	EA	-

LEGEND

- CONSTRUCTION THIS PHASE
- ACCELERATED CONSTRUCTION
- TEMPORARY BUS STOP
- TEMPORARY PAVEMENT
- DIRECTION OF TRAFFIC (TCP/EXIST)
- VERTICAL PANELS
- TYPE III BARRICADE
- CONSTRUCTION PERIMETER FENCE
- LOW PROFILE WATER FILL BARRIER
- SIGN
- PLASTIC DRUMS

- NOTES:
- CONTRACTOR SHALL PROVIDE DRIVEWAY SIGNAGE AFFIXED TO THE TOP OF PLASTIC DRUMS AT ALL DRIVEWAY LOCATIONS.
 - VIA IS RESPONSIBLE FOR ALL TEMPORARY BUS STOPS AND RELATED SIGNING. ONCE VIA SETS UP TEMPORARY BUS STOPS CONTRACTOR SHALL ENSURE SIGNAGE REMAINS VISIBLE.
 - ELIMINATE PAVEMENT MARKINGS FOR CONTRACTOR INFO ONLY (NSPI.)

PRELIMINARY
FOR INTERIM REVIEW ONLY

By: MICHAEL G. RAMIREZ P.E. 133983
 DATE 1/23/2023

CAMACHO-HERNANDEZ & ASSOCIATES, LLC
 NOT FOR CONSTRUCTION, BIDDING, OR PERMIT PURPOSES

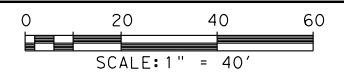

REV. NO.	DATE	DESCRIPTION	BY

CAMACHO-HERNANDEZ & ASSOCIATES, LLC
 415 EMBASSY OAKS - SUITE 205 SAN ANTONIO, TX. 78216
 OFFICE: (210) 341-6200 FAX: (210) 341-6300
 FIRM NUMBER: F-8478

PAPE-DAWSON ENGINEERS

SAN ANTONIO | AUSTIN | HOUSTON | FORT WORTH | DALLAS
 2000 NW LOOP 410 | SAN ANTONIO, TX 78213 | 210.375.9000
 TEXAS ENGINEERING FIRM #470 | TEXAS SURVEYING FIRM #10028800

CITY OF SAN ANTONIO
PUBLIC WORKS DEPARTMENT

DOLOROSA
TRAFFIC CONTROL PLAN
PHASE 2

STA 19+00 TO STA 27+00

SHEET 2 OF 6

DESIGN	CHECKED	DRAWN	PROJECT NO.	SUBMITTAL	SHEET NO.
MGR	JH	HR	23-03763	70%	65

Plotted on: 1/23/2023

Design File name: K:\COSA Dolorosa\TCP\Dolorosa_TCP_P2_03.dgn

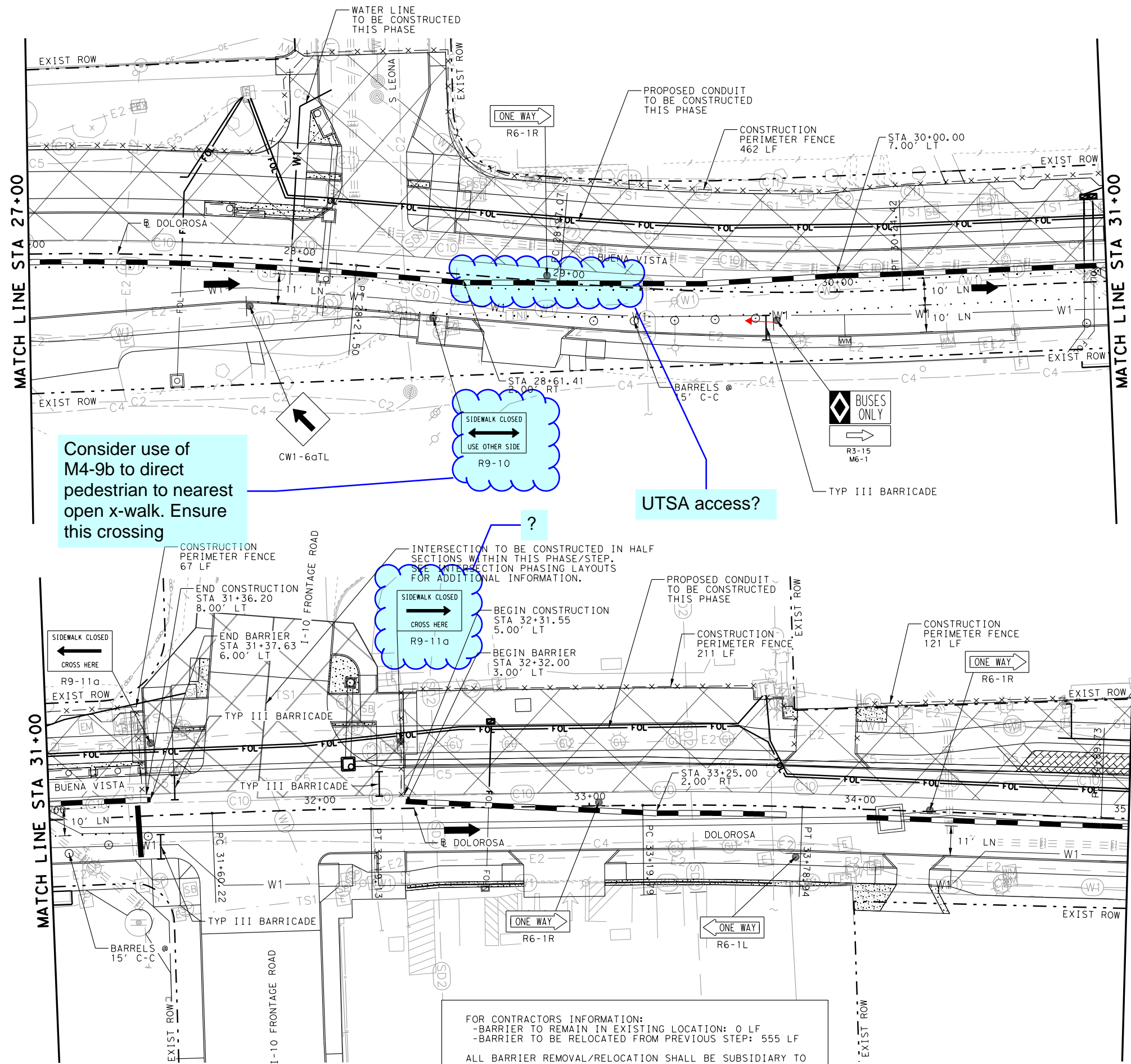

ITEM	DESCRIPTION	UNIT	QTY
540.7	CONSTRUCTION PERIMETER FENCE	LF	861
5000	WATER FILLED BARRIER	LF	100
0508-6001	CONSTRUCTING DETOURS	SY	-
0662-6063	WK ZN PAV MRK REMOV (W)4"(SLD)	LF	779
0662-6071	WK ZN PAV MRK REMOV (W)8"(SLD)	LF	-
0662-6075	WK ZN PAV MRK REMOV (W)24"(SLD)	LF	19
0667-6001	ELIM EXT PAV MRK & MRKS (4")	LF	-
0667-6003	ELIM EXT PAV MRK & MRKS (8")	LF	-
0667-6007	ELIM EXT PAV MRK & MRKS (24")	LF	-
0667-6008	ELIM EXT PAV MRK & MRKS (ARROW)	EA	-

LEGEND

- CONSTRUCTION THIS PHASE
- ACCELERATED CONSTRUCTION
- TEMPORARY BUS STOP
- TEMPORARY PAVEMENT
- DIRECTION OF TRAFFIC (TCP/EXIST)
- VERTICAL PANELS
- TYPE III BARRICADE
- CONSTRUCTION PERIMETER FENCE
- LOW PROFILE WATER FILL BARRIER
- SIGN
- PLASTIC DRUMS

- NOTES:
- CONTRACTOR SHALL PROVIDE DRIVEWAY SIGNAGE AFFIXED TO THE TOP OF PLASTIC DRUMS AT ALL DRIVEWAY LOCATIONS.
 - VIA IS RESPONSIBLE FOR ALL TEMPORARY BUS STOPS AND RELATED SIGNING. ONCE VIA SETS UP TEMPORARY BUS STOPS CONTRACTOR SHALL ENSURE SIGNAGE REMAINS VISIBLE.
 - ELIMINATE PAVEMENT MARKINGS FOR CONTRACTOR INFO ONLY (NSP1.)

PRELIMINARY
FOR INTERIM REVIEW ONLY

By: MICHAEL G. RAMIREZ P.E. 133983
DATE 1/23/2023

CAMACHO-HERNANDEZ & ASSOCIATES, LLC
NOT FOR CONSTRUCTION, BIDDING, OR PERMIT PURPOSES



REV. NO.	DATE	DESCRIPTION	BY

CAMACHO-HERNANDEZ & ASSOCIATES, LLC
415 EMBASSY OAKS - SUITE 205 SAN ANTONIO, TX. 78216
OFFICE: (210) 341-6200 FAX: (210) 341-6300
FIRM NUMBER: F-8478

PAPE-DAWSON ENGINEERS

SAN ANTONIO | AUSTIN | HOUSTON | FORT WORTH | DALLAS
2000 NW LOOP 410 | SAN ANTONIO, TX 78213 | 210.375.9000
TEXAS ENGINEERING FIRM #470 | TEXAS SURVEYING FIRM #10028800

CITY OF SAN ANTONIO
PUBLIC WORKS DEPARTMENT

DOLOROSA
TRAFFIC CONTROL PLAN
PHASE 2

STA 27+00 TO STA 35+00

SHEET 3 OF 6

DESIGN	CHECKED	DRAWN	PROJECT NO.	SUBMITTAL	SHEET NO.
MGR	JH	HR	23-03763	70%	66

FOR CONTRACTORS INFORMATION:
-BARRIER TO REMAIN IN EXISTING LOCATION: 0 LF
-BARRIER TO BE RELOCATED FROM PREVIOUS STEP: 555 LF
ALL BARRIER REMOVAL/RELOCATION SHALL BE SUBSIDIARY TO INSTALLATION COST OF WATER BARRIER. (NSP1)

Plotted on: 1/23/2023

Design File name: K:\COSA Dolorosa\TCP\Dolorosa_TCP_P2_04.dgn

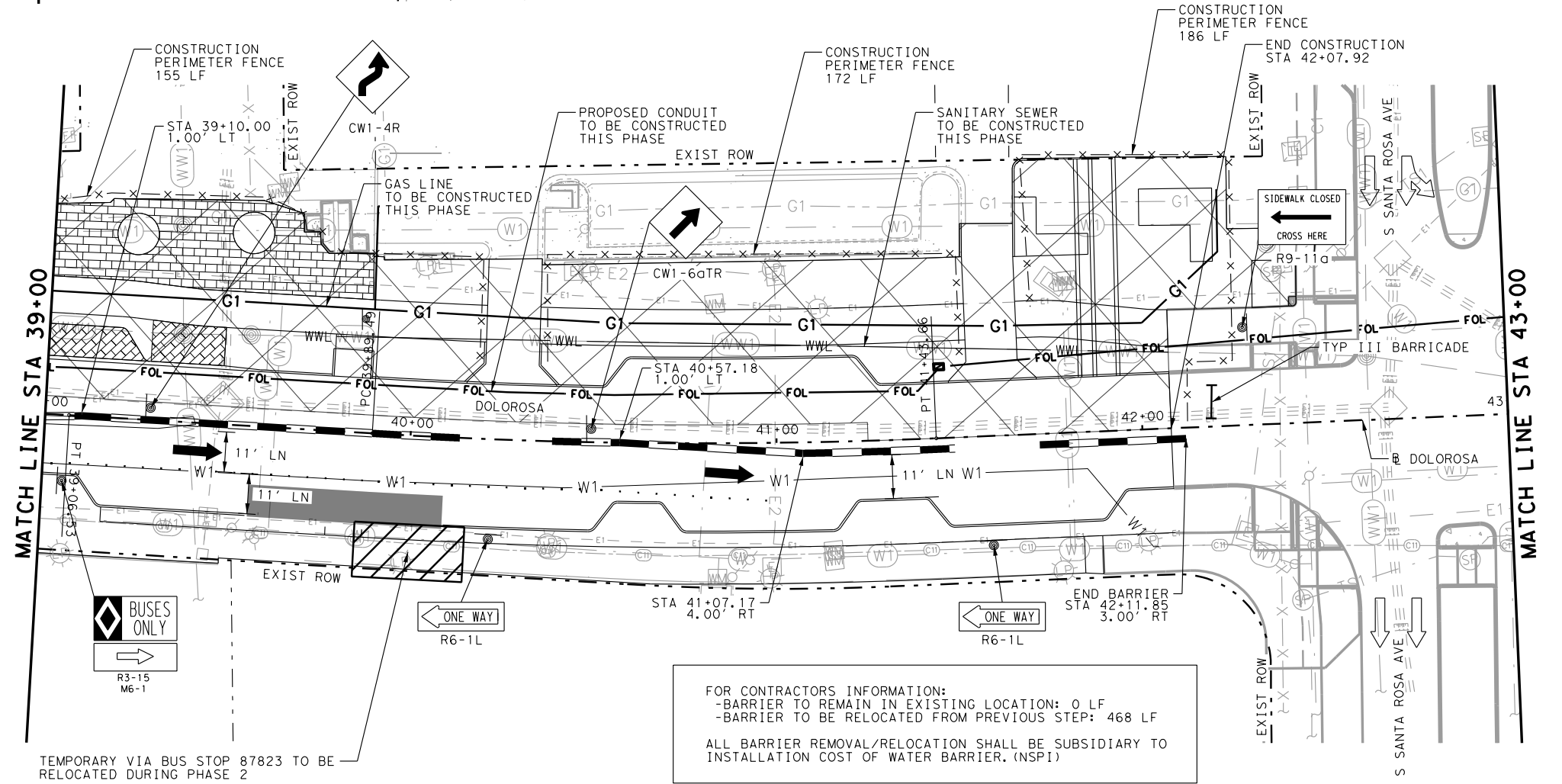
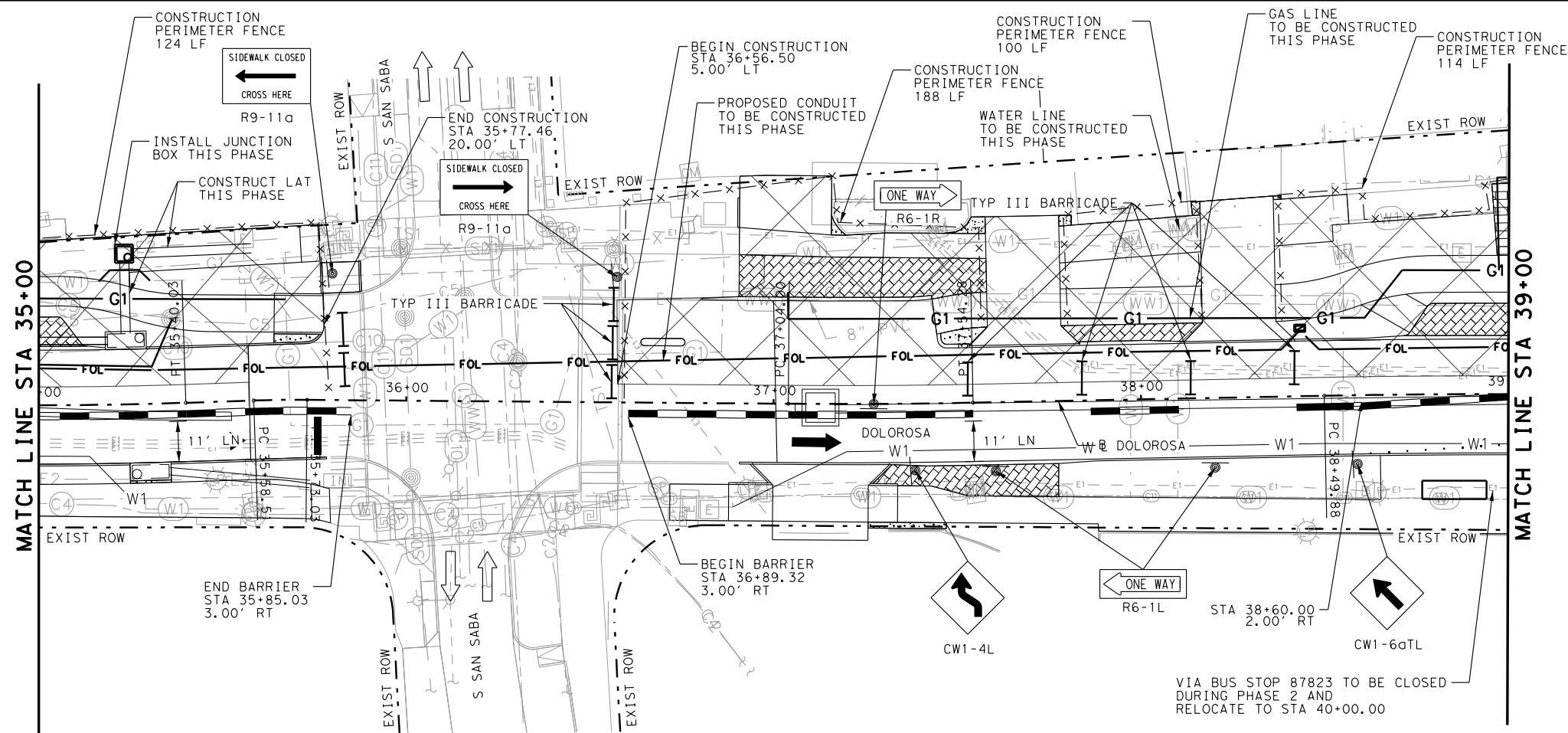

ITEM	DESCRIPTION	UNIT	QTY
540.7	CONSTRUCTION PERIMETER FENCE	LF	1039
5000	WATER FILLED BARRIER	LF	66
0508-6001	CONSTRUCTING DETOURS	SY	-
0662-6063	WK ZN PAV MRK REMOV (W)4" (SLD)	LF	241
0662-6071	WK ZN PAV MRK REMOV (W)8" (SLD)	LF	-
0662-6075	WK ZN PAV MRK REMOV (W)24" (SLD)	LF	11
0667-6001	ELIM EXT PAV MRK & MRKS (4")	LF	-
0667-6003	ELIM EXT PAV MRK & MRKS (8")	LF	-
0667-6007	ELIM EXT PAV MRK & MRKS (24")	LF	-
0667-6008	ELIM EXT PAV MRK & MRKS (ARROW)	EA	-

LEGEND

- CONSTRUCTION THIS PHASE
- ACCELERATED CONSTRUCTION
- TEMPORARY BUS STOP
- TEMPORARY PAVEMENT
- DIRECTION OF TRAFFIC (TCP/EXIST)
- VERTICAL PANELS
- TYPE III BARRICADE
- CONSTRUCTION PERIMETER FENCE
- LOW PROFILE WATER FILL BARRIER
- SIGN
- PLASTIC DRUMS

- NOTES:
- CONTRACTOR SHALL PROVIDE DRIVEWAY SIGNAGE AFFIXED TO THE TOP OF PLASTIC DRUMS AT ALL DRIVEWAY LOCATIONS.
 - VIA IS RESPONSIBLE FOR ALL TEMPORARY BUS STOPS AND RELATED SIGNING. ONCE VIA SETS UP TEMPORARY BUS STOPS CONTRACTOR SHALL ENSURE SIGNAGE REMAINS VISIBLE.
 - ELIMINATE PAVEMENT MARKINGS FOR CONTRACTOR INFO ONLY (NSP1.)

PRELIMINARY
FOR INTERIM REVIEW ONLY

By: MICHAEL G. RAMIREZ P.E. 133983
DATE 1/23/2023

CAMACHO-HERNANDEZ & ASSOCIATES, LLC
NOT FOR CONSTRUCTION, BIDDING, OR PERMIT PURPOSES

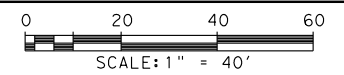

REV. NO.	DATE	DESCRIPTION	BY

CAMACHO-HERNANDEZ & ASSOCIATES, LLC
415 EMBASSY OAKS - SUITE 205 SAN ANTONIO, TX. 78216
OFFICE: (210) 341-6200 FAX: (210) 341-6300
FIRM NUMBER: F-8478

PAPE-DAWSON ENGINEERS

SAN ANTONIO | AUSTIN | HOUSTON | FORT WORTH | DALLAS
2000 NW LOOP 410 | SAN ANTONIO, TX 78213 | 210.375.9000
TEXAS ENGINEERING FIRM #470 | TEXAS SURVEYING FIRM #10028800

CITY OF SAN ANTONIO
PUBLIC WORKS DEPARTMENT

DOLOROSA
TRAFFIC CONTROL PLAN
PHASE 2

STA 35+00 TO STA 43+00

SHEET 4 OF 6

DESIGN	CHECKED	DRAWN	PROJECT NO.	SUBMITTAL	SHEET NO.
MGR	JH	HR	23-03763	70%	67

FOR CONTRACTORS INFORMATION:
-BARRIER TO REMAIN IN EXISTING LOCATION: 0 LF
-BARRIER TO BE RELOCATED FROM PREVIOUS STEP: 468 LF
ALL BARRIER REMOVAL/RELOCATION SHALL BE SUBSIDIARY TO INSTALLATION COST OF WATER BARRIER. (NSP1)

Plotted on: 1/23/2023

Design File name: K:\COSA Dolorosa\TCP\Dolorosa_TCP_P2_05.dgn

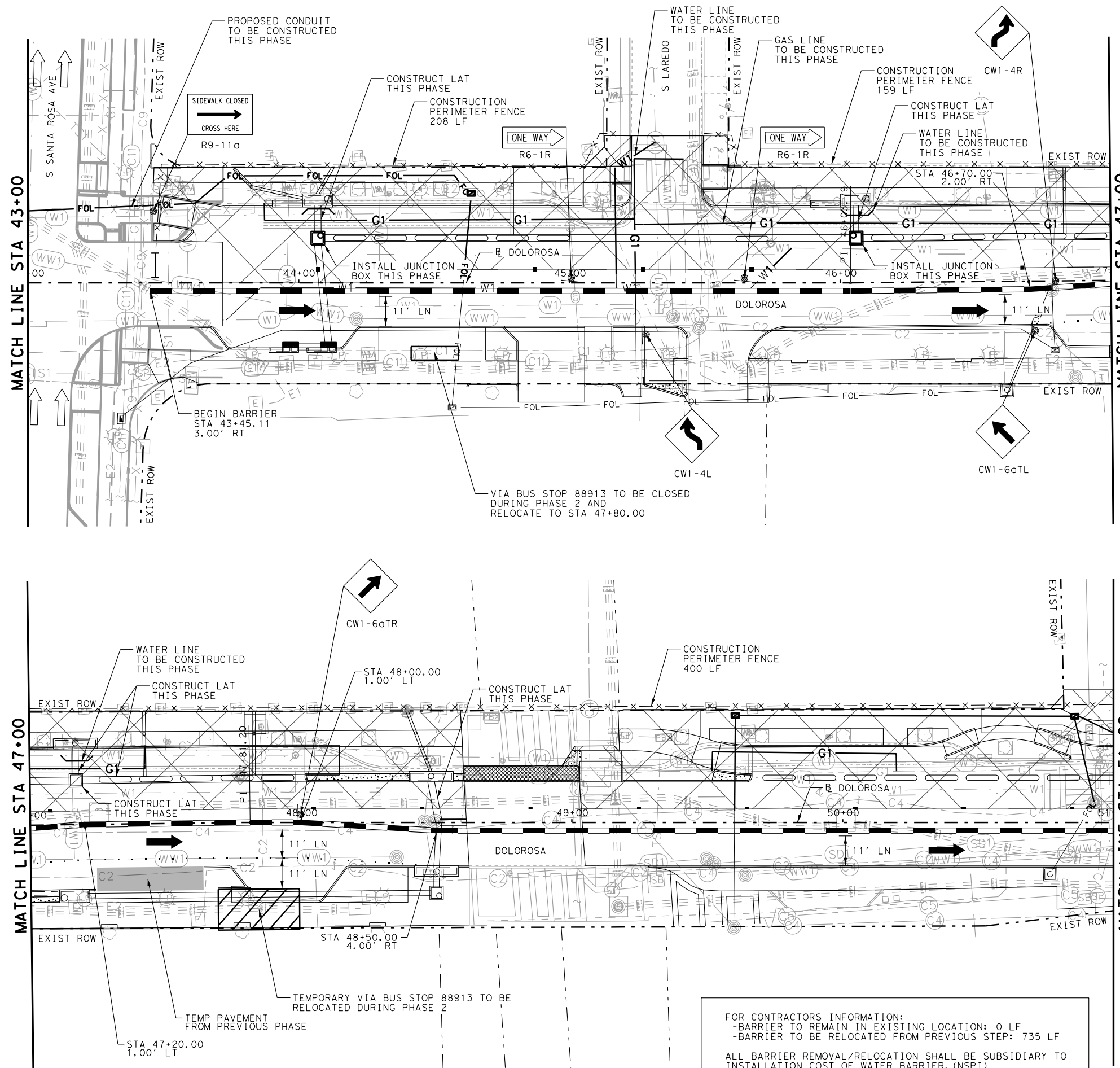

ITEM	DESCRIPTION	UNIT	QTY
540.7	CONSTRUCTION PERIMETER FENCE	LF	767
5000	WATER FILLED BARRIER	LF	20
0508-6001	CONSTRUCTING DETOURS	SY	-
0662-6063	WK ZN PAV MRK REMOV (W)4" (SLD)	LF	180
0662-6071	WK ZN PAV MRK REMOV (W)8" (SLD)	LF	-
0662-6075	WK ZN PAV MRK REMOV (W)24" (SLD)	LF	-
0667-6001	ELIM EXT PAV MRK & MRKS (4")	LF	-
0667-6003	ELIM EXT PAV MRK & MRKS (8")	LF	-
0667-6007	ELIM EXT PAV MRK & MRKS (24")	LF	-
0667-6008	ELIM EXT PAV MRK & MRKS (ARROW)	EA	-

LEGEND

- CONSTRUCTION THIS PHASE
- ACCELERATED CONSTRUCTION
- TEMPORARY BUS STOP
- TEMPORARY PAVEMENT
- DIRECTION OF TRAFFIC (TCP/EXIST)
- VERTICAL PANELS
- TYPE III BARRICADE
- CONSTRUCTION PERIMETER FENCE
- LOW PROFILE WATER FILL BARRIER
- SIGN
- PLASTIC DRUMS

- NOTES:
- CONTRACTOR SHALL PROVIDE DRIVEWAY SIGNAGE AFFIXED TO THE TOP OF PLASTIC DRUMS AT ALL DRIVEWAY LOCATIONS.
 - VIA IS RESPONSIBLE FOR ALL TEMPORARY BUS STOPS AND RELATED SIGNING. ONCE VIA SETS UP TEMPORARY BUS STOPS CONTRACTOR SHALL ENSURE SIGNAGE REMAINS VISIBLE.
 - ELIMINATE PAVEMENT MARKINGS FOR CONTRACTOR INFO ONLY (NSPI.)

PRELIMINARY
FOR INTERIM REVIEW ONLY

By: MICHAEL G. RAMIREZ P.E. 133983
DATE 1/23/2023

CAMACHO-HERNANDEZ & ASSOCIATES, LLC
NOT FOR CONSTRUCTION, BIDDING, OR PERMIT PURPOSES

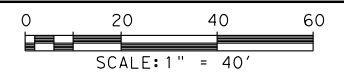

REV. NO.	DATE	DESCRIPTION	BY

CAMACHO-HERNANDEZ & ASSOCIATES, LLC
415 EMBASSY OAKS - SUITE 205 SAN ANTONIO, TX. 78216
OFFICE: (210) 341-6200 FAX: (210) 341-6300
FIRM NUMBER: F-8478

PAPE-DAWSON ENGINEERS

SAN ANTONIO | AUSTIN | HOUSTON | FORT WORTH | DALLAS
2000 NW LOOP 410 | SAN ANTONIO, TX 78213 | 210.375.9000
TEXAS ENGINEERING FIRM #470 | TEXAS SURVEYING FIRM #10028800

CITY OF SAN ANTONIO
PUBLIC WORKS DEPARTMENT

DOLOROSA
TRAFFIC CONTROL PLAN
PHASE 2

STA 43+00 TO STA 51+00

SHEET 5 OF 6

DESIGN	CHECKED	DRAWN	PROJECT NO.	SUBMITTAL	SHEET NO.
MGR	JH	HR	23-03763	70%	68









FOR CONTRACTORS INFORMATION:
-BARRIER TO REMAIN IN EXISTING LOCATION: 0 LF
-BARRIER TO BE RELOCATED FROM PREVIOUS STEP: 735 LF
ALL BARRIER REMOVAL/RELOCATION SHALL BE SUBSIDIARY TO INSTALLATION COST OF WATER BARRIER. (NSPI)

Plotted on: 1/23/2023

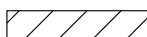
Design File name: K:\COSA Dolorosa\TCP\Dolorosa_TCP_P2_06.dgn

ITEM	DESCRIPTION	UNIT	QTY
540.7	CONSTRUCTION PERIMETER FENCE	LF	367
5000	WATER FILLED BARRIER	LF	20
0508-6001	CONSTRUCTING DETOURS	SY	-
0662-6063	WK ZN PAV MRK REMOV (W)4"(SLD)	LF	-
0662-6071	WK ZN PAV MRK REMOV (W)8"(SLD)	LF	82
0662-6075	WK ZN PAV MRK REMOV (W)24"(SLD)	LF	22
0667-6001	ELIM EXT PAV MRK & MRKS (4")	LF	-
0667-6003	ELIM EXT PAV MRK & MRKS (8")	LF	-
0667-6007	ELIM EXT PAV MRK & MRKS (24")	LF	-
0667-6008	ELIM EXT PAV MRK & MRKS (ARROW)	EA	-

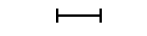
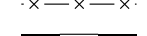
LEGEND

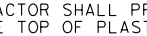
-  CONSTRUCTION THIS PHASE
-  ACCELERATED CONSTRUCTION
-  TEMPORARY BUS STOP
-  TEMPORARY PAVEMENT
-  DIRECTION OF TRAFFIC (TCP/EXIST)
-  VERTICAL PANELS
-  TYPE III BARRICADE
-  CONSTRUCTION PERIMETER FENCE
-  LOW PROFILE WATER FILL BARRIER
-  SIGN
-  PLASTIC DRUMS

- NOTES:
- CONTRACTOR SHALL PROVIDE DRIVEWAY SIGNAGE AFFIXED TO THE TOP OF PLASTIC DRUMS AT ALL DRIVEWAY LOCATIONS.
 - VIA IS RESPONSIBLE FOR ALL TEMPORARY BUS STOPS AND RELATED SIGNING. ONCE VIA SETS UP TEMPORARY BUS STOPS CONTRACTOR SHALL ENSURE SIGNAGE REMAINS VISIBLE.
 - ELIMINATE PAVEMENT MARKINGS FOR CONTRACTOR INFO ONLY (NSPI.)

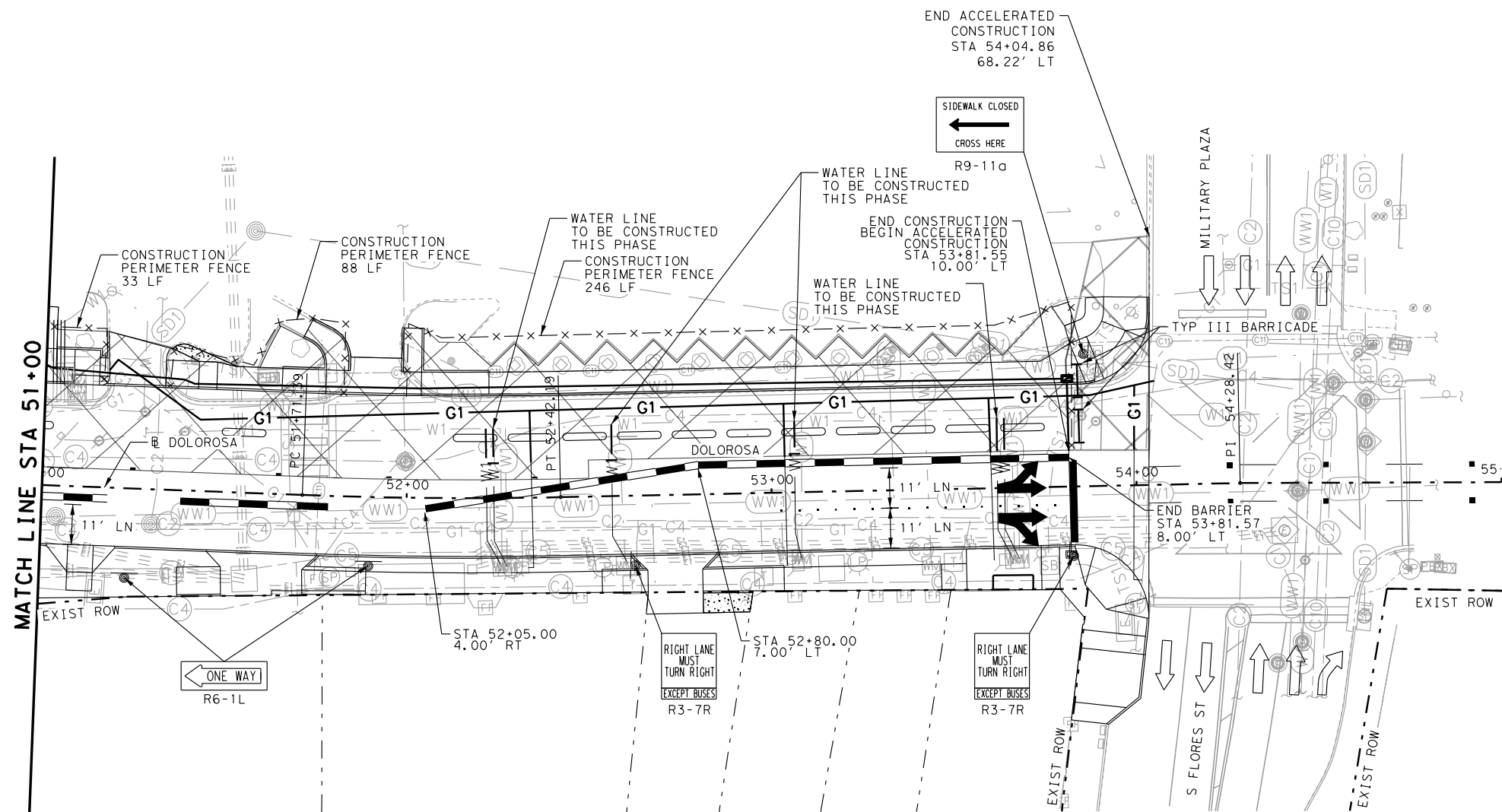

FOR CONTRACTORS INFORMATION:
 -BARRIER TO REMAIN IN EXISTING LOCATION: 0 LF
 -BARRIER TO BE RELOCATED FROM PREVIOUS STEP: 216 LF
 ALL BARRIER REMOVAL/RELOCATION SHALL BE SUBSIDIARY TO INSTALLATION COST OF WATER BARRIER. (NSPI)

PRELIMINARY
 FOR INTERIM REVIEW ONLY

By: MICHAEL G. RAMIREZ P.E. 133983
 DATE 1/23/2023

CAMACHO-HERNANDEZ & ASSOCIATES, LLC
 NOT FOR CONSTRUCTION, BIDDING, OR PERMIT PURPOSES



REV. NO.	DATE	DESCRIPTION	BY

CAMACHO-HERNANDEZ & ASSOCIATES, LLC
 415 EMBASSY OAKS - SUITE 205 SAN ANTONIO, TX. 78216
 OFFICE: (210) 341-6200 FAX: (210) 341-6300
 FIRM NUMBER: F-8478



SAN ANTONIO | AUSTIN | HOUSTON | FORT WORTH | DALLAS
 2000 NW LOOP 410 | SAN ANTONIO, TX 78213 | 210.375.9000
 TEXAS ENGINEERING FIRM #470 | TEXAS SURVEYING FIRM #10028800

CITY OF SAN ANTONIO
PUBLIC WORKS DEPARTMENT

DOLOROSA
TRAFFIC CONTROL PLAN
 PHASE 2

STA 51+00 TO END

SHEET 6 OF 6

DESIGN	CHECKED	DRAWN	PROJECT NO.	SUBMITTAL	SHEET NO.
MGR	JH	HR	23-03763	70%	69

Plotted on: 1/23/2023

Design File name: K:\COSA Dolorosa\TCP\Dolorosa_TCP_INT_Flores.dgn

Confirm no VIA stop relocation needed.
If needed, add note for coordination
and identify alternate stop location.

270ft goes practically
to Flores. Assess
spacing and signage
requirements for
urban condition.

Clarify visually or with notes that this
sheet does not indicate full closure of
the Dolorosa approach to Flores.

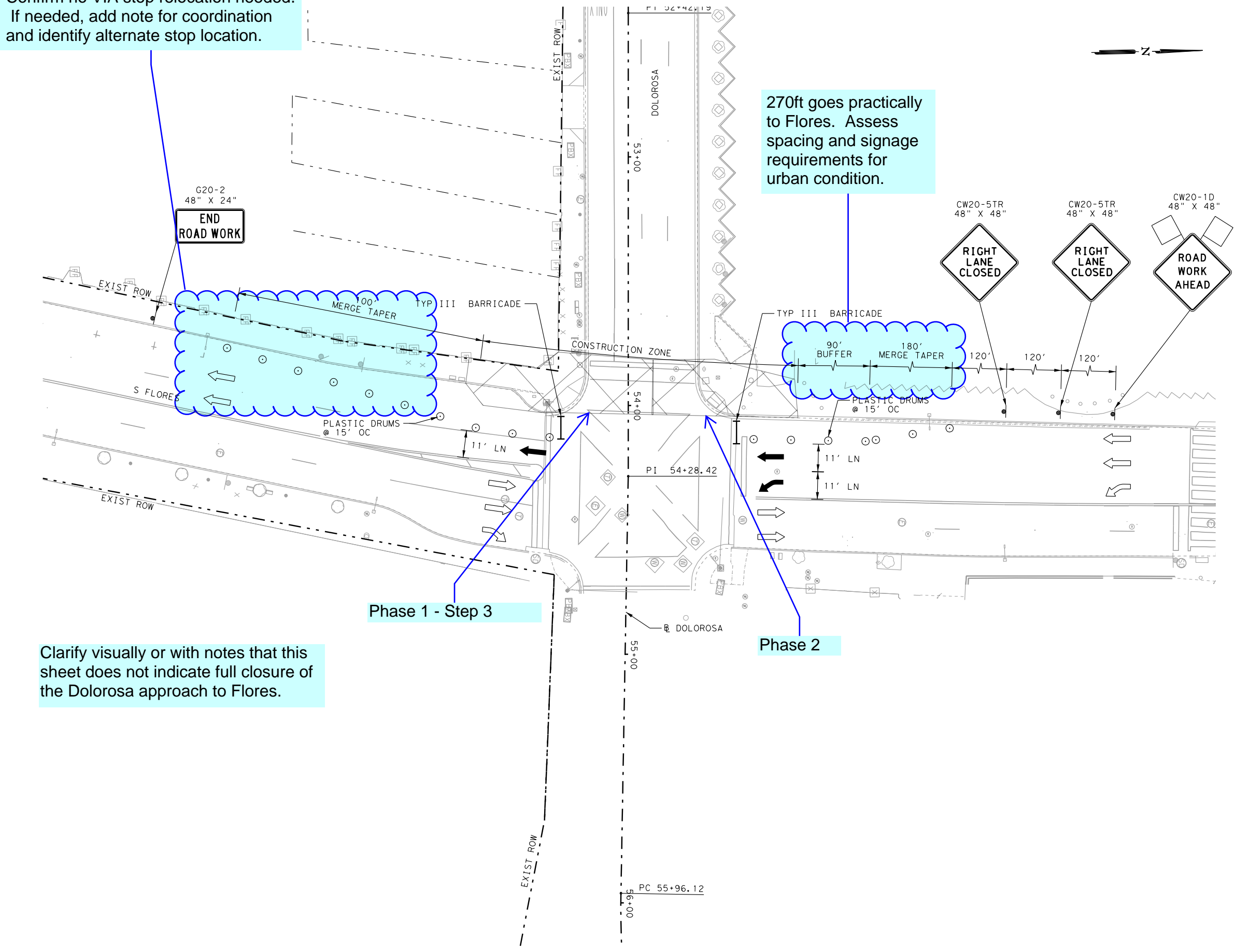

LEGEND

- ACCELERATED CONSTRUCTION
- DIRECTION OF TRAFFIC (TCP/EXIST)
- VERTICAL PANELS
- TYPE III BARRICADE
- LOW PROFILE WATER FILL BARRIER
- SIGN
- PLASTIC DRUMS

NOTE:

- INTERSECTION CLOSURE LAYOUT TO BE UTILIZED CONCURRENTLY WITH THE TCP LAID OUT WITHIN PHASING LAYOUTS WHEN APPLICABLE.
- INTERSECTION CLOSURE TO BE DONE DURING ACCELERATED CONSTRUCTION TIMING.
- CROSS STREETS TO BE OPENED AS SOON AS POSSIBLE.

PRELIMINARY
FOR INTERIM REVIEW ONLY

By: MICHAEL G. RAMIREZ P.E. 133983
DATE 1/23/2023

CAMACHO-HERNANDEZ & ASSOCIATES, LLC
NOT FOR CONSTRUCTION, BIDDING, OR PERMIT PURPOSES

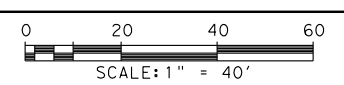

REV. NO.	DATE	DESCRIPTION	BY
CAMACHO-HERNANDEZ & ASSOCIATES, LLC 415 EMBASSY OAKS - SUITE 205 SAN ANTONIO, TX. 78216 OFFICE: (210) 341-6200 FAX: (210) 341-6300 FIRM NUMBER: F-8478			

PAPE-DAWSON ENGINEERS

SAN ANTONIO | AUSTIN | HOUSTON | FORT WORTH | DALLAS
 2000 NW LOOP 410 | SAN ANTONIO, TX 78213 | 210.375.9000
 TEXAS ENGINEERING FIRM #470 | TEXAS SURVEYING FIRM #10028800

CITY OF SAN ANTONIO
PUBLIC WORKS DEPARTMENT

DOLOROSA
TRAFFIC CONTROL PLAN
INTERSECTION CLOSURE

DOLOROSA / FLORES

SHEET 1 OF 3

DESIGN	CHECKED	DRAWN	PROJECT NO.	SUBMITTAL	SHEET NO.
MGR	JH	HR	23-03763	70%	70





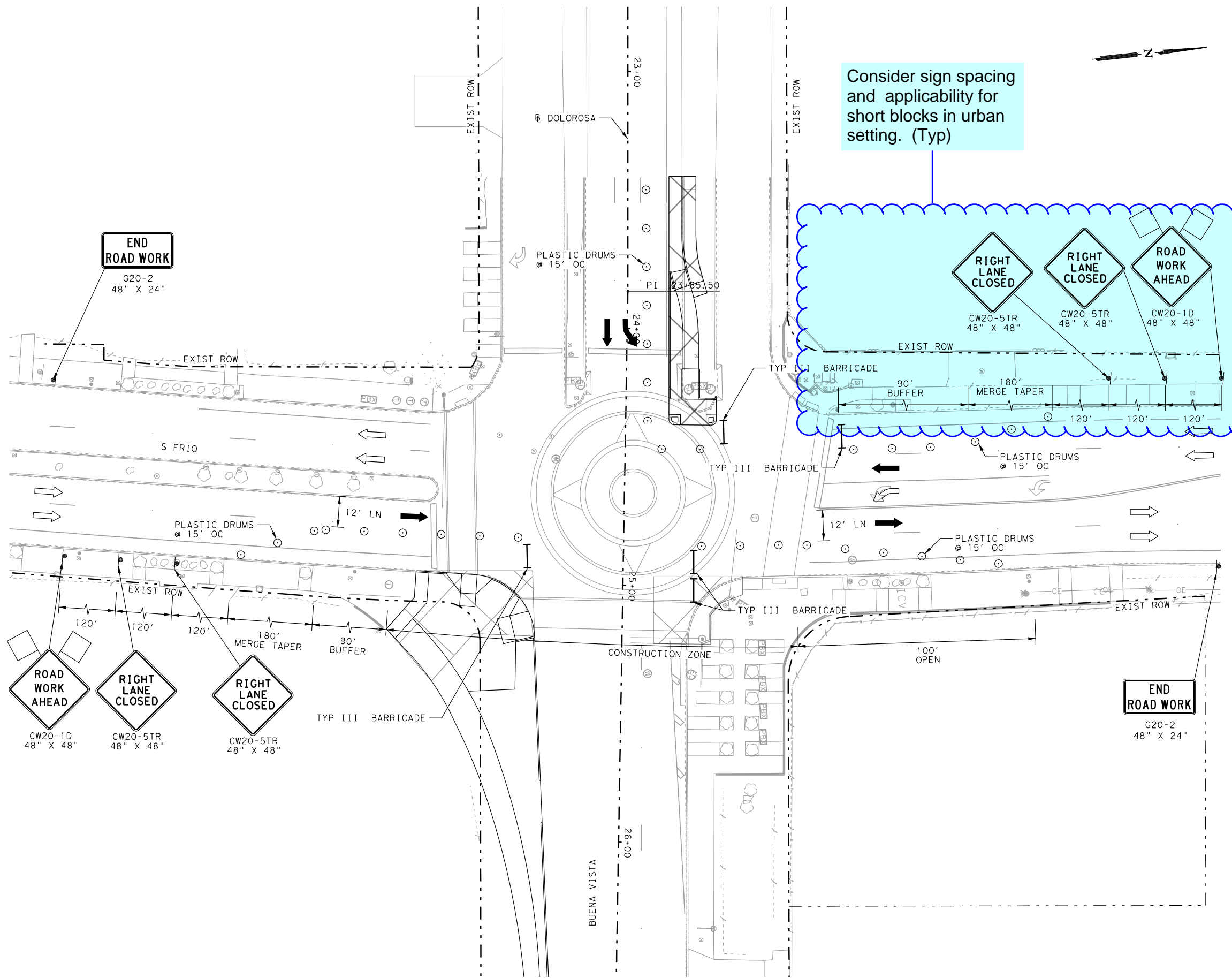

Plotted on: 1/23/2023

Design File name: K:\COSA Dolorosa\TCP\Dolorosa_TCP_INT_Frio.dgn



Consider sign spacing and applicability for short blocks in urban setting. (Typ)

LEGEND

-  ACCELERATED CONSTRUCTION
-  DIRECTION OF TRAFFIC (TCP/EXIST)
-  VERTICAL PANELS
-  TYPE III BARRICADE
-  LOW PROFILE WATER FILL BARRIER
-  SIGN
-  PLASTIC DRUMS

- NOTE:
1. INTERSECTION CLOSURE LAYOUT TO BE UTILIZED CONCURRENTLY WITH THE TCP LAID OUT WITHIN PHASING LAYOUTS WHEN APPLICABLE.
 2. INTERSECTION CLOSURE TO BE DONE DURING ACCELERATED CONSTRUCTION TIMING.
 3. CROSS STREETS TO BE OPENED AS SOON AS POSSIBLE.

PRELIMINARY
FOR INTERIM REVIEW ONLY

By: MICHAEL G. RAMIREZ P.E. 133983
DATE 1/23/2023

CAMACHO-HERNANDEZ & ASSOCIATES, LLC
NOT FOR CONSTRUCTION, BIDDING, OR PERMIT PURPOSES

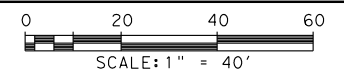

REV. NO.	DATE	DESCRIPTION	BY
CAMACHO-HERNANDEZ & ASSOCIATES, LLC 415 EMBASSY OAKS - SUITE 205 SAN ANTONIO, TX. 78216 OFFICE: (210) 341-6200 FAX: (210) 341-6300 FIRM NUMBER: F-8478			

PAPE-DAWSON ENGINEERS

SAN ANTONIO | AUSTIN | HOUSTON | FORT WORTH | DALLAS
2000 NW LOOP 410 | SAN ANTONIO, TX 78213 | 210.375.9000
TEXAS ENGINEERING FIRM #470 | TEXAS SURVEYING FIRM #10028800

 CITY OF SAN ANTONIO
PUBLIC WORKS DEPARTMENT

DOLOROSA
**TRAFFIC CONTROL PLAN
INTERSECTION CLOSURE**

BUENA VISTA / FRIO

SHEET 2 OF 3

DESIGN	CHECKED	DRAWN	PROJECT NO.	SUBMITTAL	SHEET NO.
MGR	JH	HR	23-03763	70%	71

Plotted on: 1/23/2023

Design File name: K:\COSA Dolorosa\TCP\Dolorosa_TCP_INT_IH10 Frontage.dgn

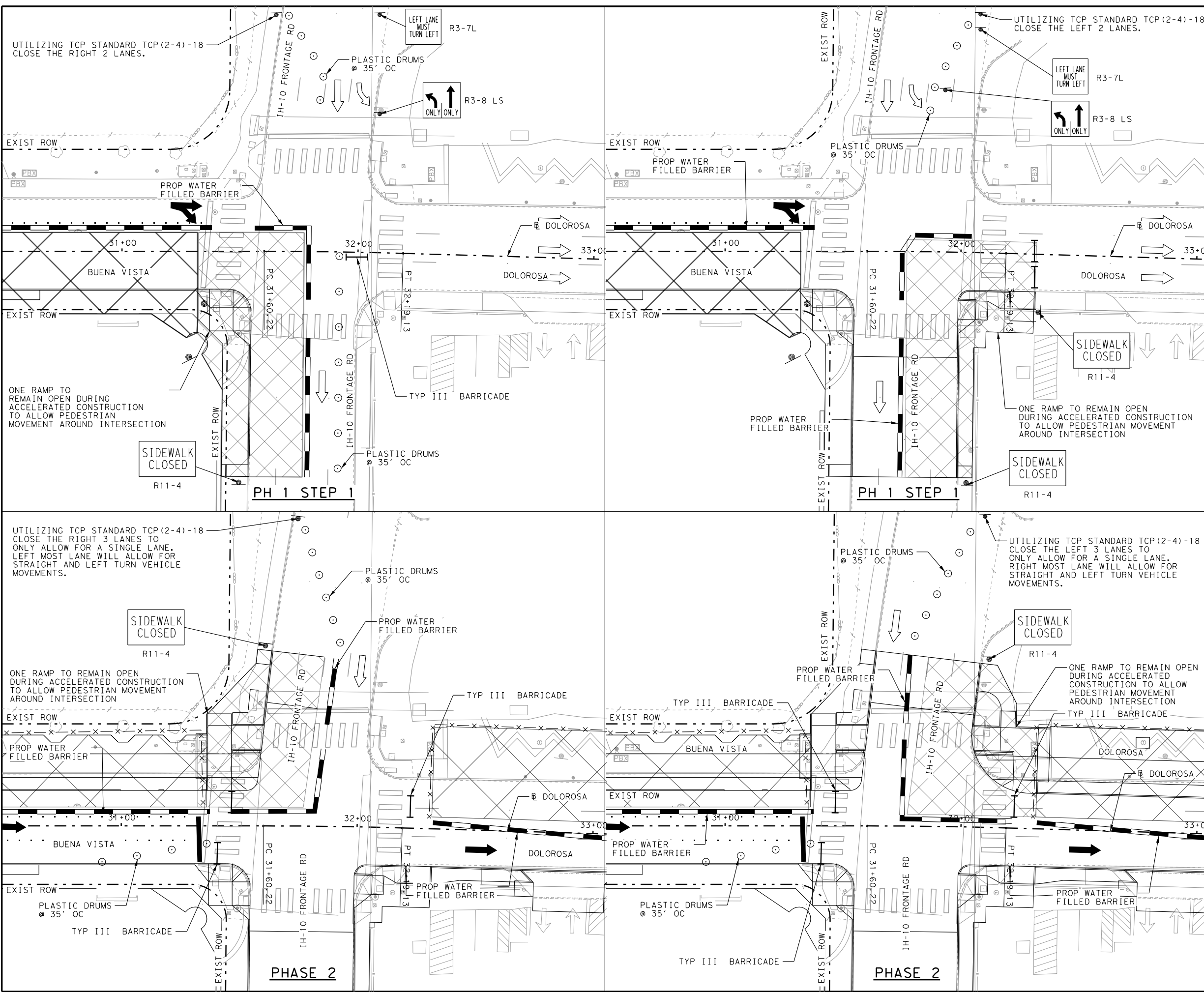

LEGEND

- ACCELERATED CONSTRUCTION
- TRAFFIC FLOW (TCP/EXIST)
- VERTICAL PANELS
- TYPE III BARRICADE
- LOW PROFILE WATER FILLED BARRIER
- SIGN
- PLASTIC DRUMS

PRELIMINARY

FOR INTERIM REVIEW ONLY

By: MICHAEL G. RAMIREZ P.E. 133983
DATE 1/23/2023

CAMACHO-HERNANDEZ & ASSOCIATES, LLC
NOT FOR CONSTRUCTION, BIDDING, OR PERMIT PURPOSES

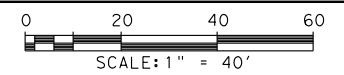

REV. NO.	DATE	DESCRIPTION	BY

CAMACHO-HERNANDEZ & ASSOCIATES, LLC
415 EMBASSY OAKS - SUITE 205 SAN ANTONIO, TX. 78216
OFFICE: (210) 341-6200 FAX: (210) 341-6300
FIRM NUMBER: F-8478



SAN ANTONIO | AUSTIN | HOUSTON | FORT WORTH | DALLAS
2000 NW LOOP 410 | SAN ANTONIO, TX 78213 | 210.375.9000
TEXAS ENGINEERING FIRM #470 | TEXAS SURVEYING FIRM #10028800



**TRAFFIC CONTROL PLAN
INTERSECTION CLOSURE**

BUENA VISTA / IH10 FRONTAGE RD
SHEET 3 OF 3

DESIGN	CHECKED	DRAWN	PROJECT NO.	SUBMITTAL	SHEET NO.
MGR	JH	HR	23-03763	70%	72

TRAFFIC NOTES

TRENCHING / EXCAVATING

The following notes shall apply to excavations of trenches or pits that are located in the pavement or are within six (6) feet of the edge of roadway:

- 1.) Trench walls shall not be closer than three (3) feet from the edge of the traveled way at any stage of construction.
- 2.) Traffic control devices shall be in place before starting any excavation.
- 3.) Trenches or pits will not be permitted to be bridged by steel plates and open to traffic unless they are temporarily backfilled to finished street grade.
- 4.) For pits or trenches along or in a roadway that are going to be left open over night that are zero to fifty (0 - 50) feet in length, the following applies. **GUARD RAIL OR CONCRETE BARRIER SHALL BE USED.**
- 5.) For pits or trenches along or in roadway that are going to be left open over night and are longer than 50 feet in length. **CONCRETE BARRIERS MUST BE USED.**
- 6.) Plastic construction fencing shall be required for any trench or pit left open over night.
- 7.) When using any guardrail or concrete barrier, protected end must be used as per the TEXAS-M.U.T.C.D.
- 8.) For vertical drop-offs greater than two (2) feet along roadway, low profile concrete with appropriate end protection must be installed.
- 9.) All concrete barriers placed on City R.O.W shall be low profile. No high profile barriers will be allowed.

REFLECTIVE SHEETING

The reflectorized white and reflectorized orange stripes for channelizing devices such as barricade drums and vertical panels shall be constructed of reflective sheeting meeting the color and retro-reflectivity requirements of high intensity, unless otherwise specified in the plans.

MAINTENANCE

- 1.) All traffic signs shall be kept in proper position, clean and legible at all times. Damaged barricades, signs, and other traffic control devices shall be replaced without undue delay.
- 2.) To ensure adequate maintenance, a suitable schedule for inspection, cleaning, and replacement of barricades, lights, and signs shall be established.
- 3.) Special attention and necessary action shall be taken to see that weeds, trees, shrubbery and construction materials do not obscure the face of any sign or barricades.

TRAINING

Each person whose actions affect maintenance and construction zone safety, from the upper-level management personnel through construction and maintenance field personnel, should receive training appropriate to the job decision each individual is required to make. Only those individuals who are qualified by means of adequate training in safe traffic control practices and have a basic understanding of the principles established by applicable standards and regulations, including those of the TEXAS M.U.T.C.D. should supervise the selection, placement, and maintenance of traffic control devices in maintenance and construction areas.

SPECIAL EVENTS BARRICADING

All Type I, (8') barricades used for special events (Dome, Runs, Walks, Parades etc.) shall be a minimum of 42" high and 96" wide. Any necessary signs will require proper sign stands.

USE OF CITY R.O.W.

The City of San Antonio reserves the right to allow contracting and barricading sub-contractors to use the City's R.O.W. The City also reserves the right to advise contractors and barricading sub-contractors to remove stored or unused traffic control devices from the City of San Antonio R.O.W. It is the barricading sub-contractor's responsibility to remove any traffic control device from City's R.O.W. when instructed to do so by a City representative.

CLOSURE DIAGRAMS

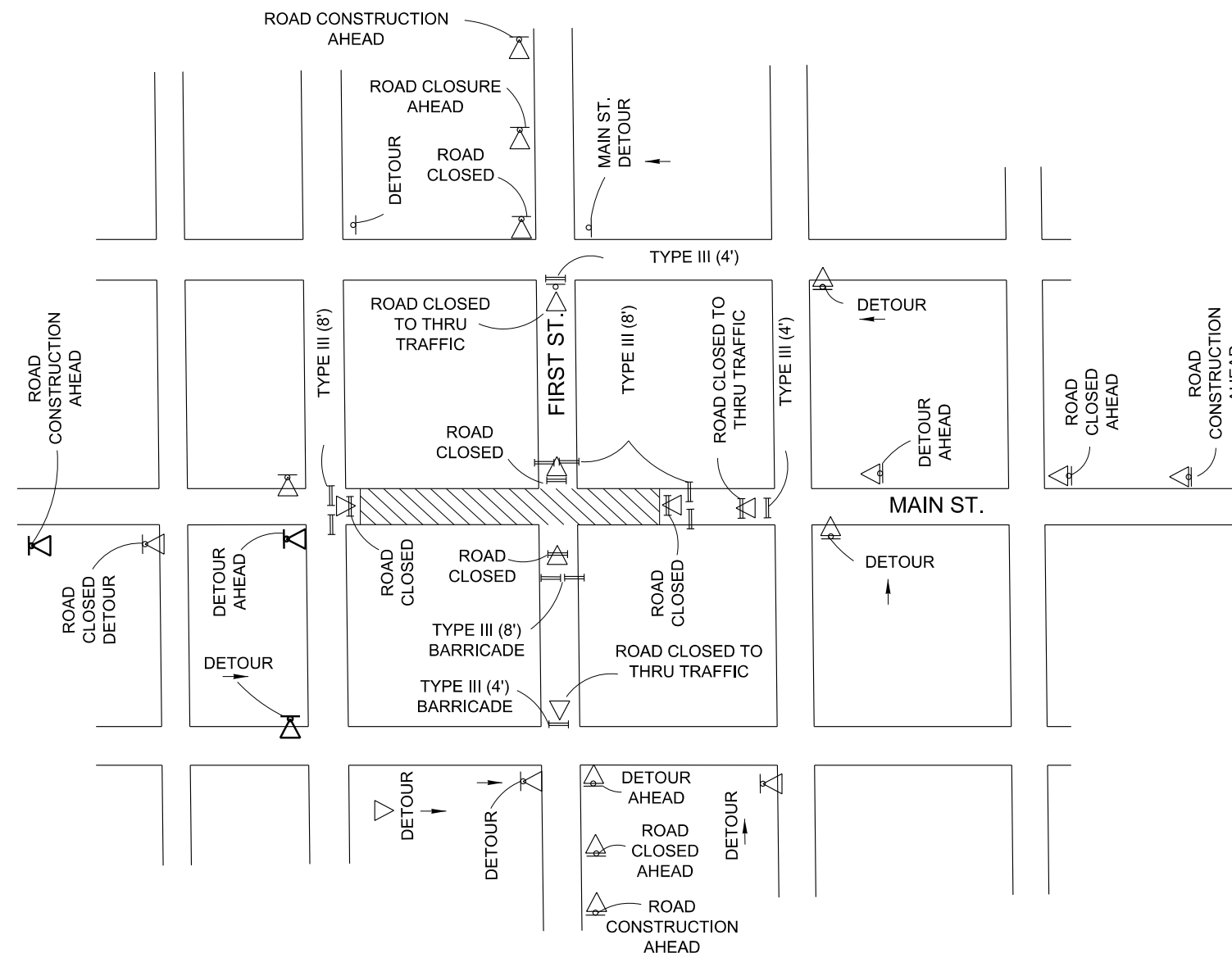

TYPICAL INTERSECTING STREET CLOSURE FOR TWO LANE STREETS

NOTE:
ALL SIGNS WILL BE
MOUNTED ON SIGN
SUPPORTS ONLY

THE ORIGINAL OF THIS DRAWING WAS SIGNED AND SEALED BY JOHN D. FRIEBELE #46394 ON 06-20-05 AND IS ON FILE WITH THE TRAFFIC ENGINEERING DIVISION OF THE PUBLIC WORKS DEPARTMENT, CITY OF SAN ANTONIO.

JUNE 2005			
CITY OF SAN ANTONIO			
DEPARTMENT OF PUBLIC WORKS			
TRAFFIC STANDARDS			
BARRICADE AND CONSTRUCTION STANDARDS			
SHEET 1 OF 4			
70% SUBMITTAL	PROJECT NO.: 23-03763	DATE: 1/20/2023	
DRWN. BY: A.F.G.	DSGN. BY: E.N.M.	CHKD. BY: J.D.F./E.N.M.	SHEET NO.: 73 OF 521

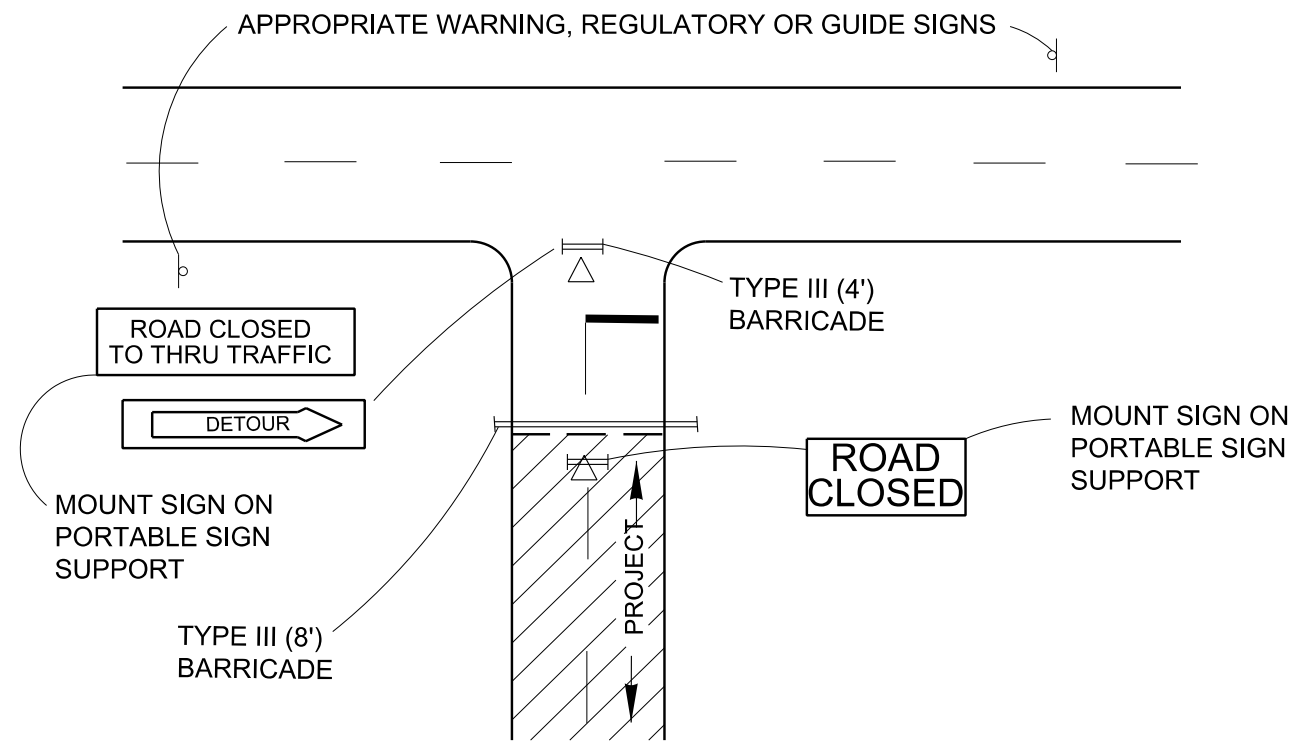

PROJECT LIMITS FOR CLOSED ROADWAY

BARRICADES SHALL BE ERECTED COMPLETELY ACROSS ROADWAY. CHANNELIZING DEVICES MAY BE DRUMS, VERTICAL PANELS OR CONES AS SPECIFIED IN THE PLANS

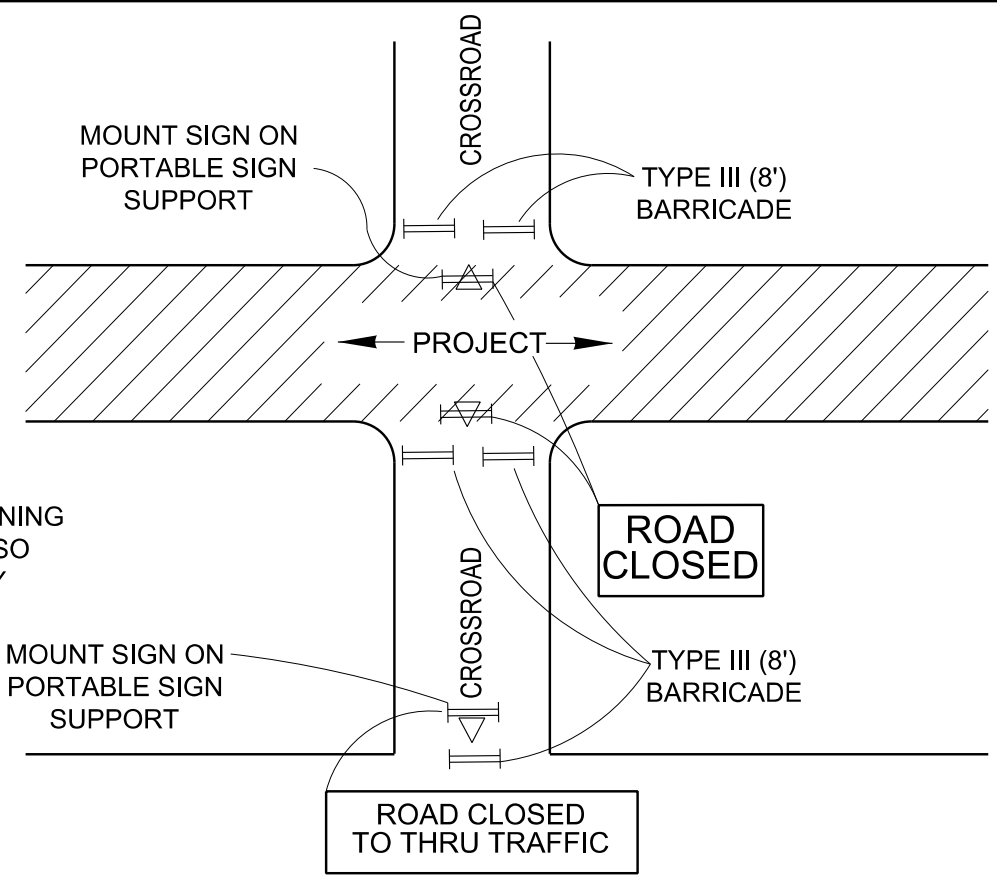

NOTE:
ADVANCE WARNING
SIGNS WILL ALSO
BE NECESSARY

**CROSS STREET SIGNING AND BARRICADING
TOTALLY CLOSED**

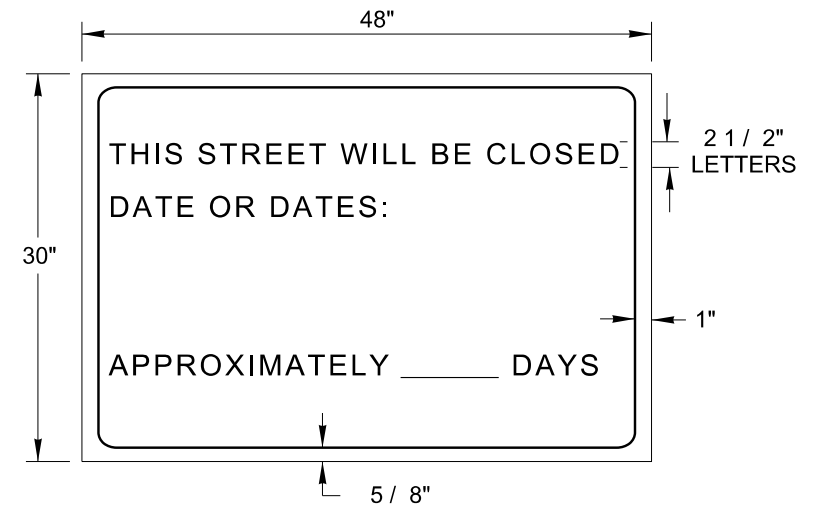

LETTERS- BLACK
BORDER- BLACK
BACKGROUND- ORANGE

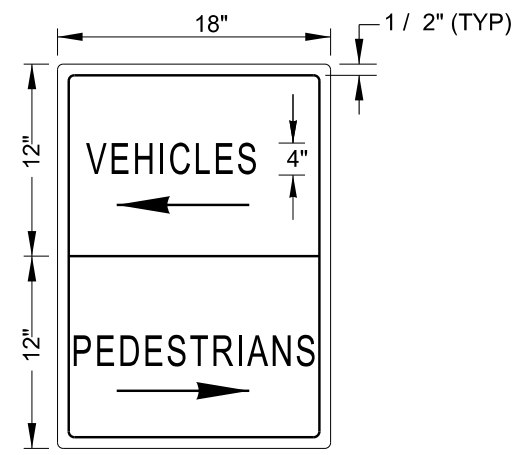

LETTERS- BLACK
BORDER- BLACK
BACKGROUND- ORANGE
SPACING-3 SIGNS PER BLOCK

DIRECTION OF ARROWS
ARE REVERSIBLE

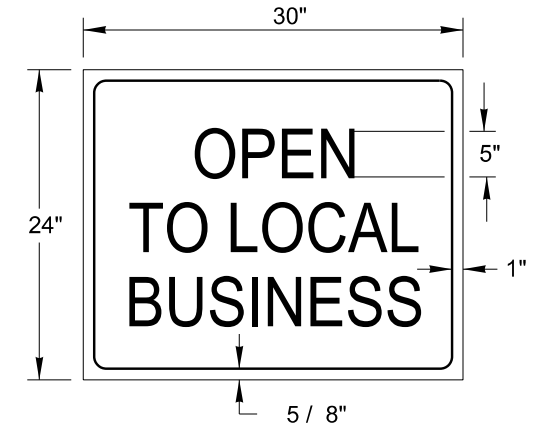

LETTERS- WHITE
BORDER- WHITE
BACKGROUND- BLUE REFLECTIVE

THE ORIGINAL OF THIS DRAWING WAS SIGNED AND SEALED BY JOHN D. FRIEBELE, #46394 ON 06-20-05 AND IS ON FILE WITH THE TRAFFIC ENGINEERING DIVISION OF THE PUBLIC WORKS DEPARTMENT, CITY OF SAN ANTONIO.

JUNE 2005			
CITY OF SAN ANTONIO			
DEPARTMENT OF PUBLIC WORKS			
TRAFFIC STANDARDS			
BARRICADE AND CONSTRUCTION			
STANDARDS			
SHEET 2 OF 4			
70% SUBMITTAL	PROJECT NO. 23-03763	DATE: 1/20/2023	
DRWN. BY: A.F.G.	DSGN. BY: E.N.M.	CHKD. BY: J.D.F./ E.N.M.	SHEET NO.: 74 OF 521

TYPE I BARRICADE

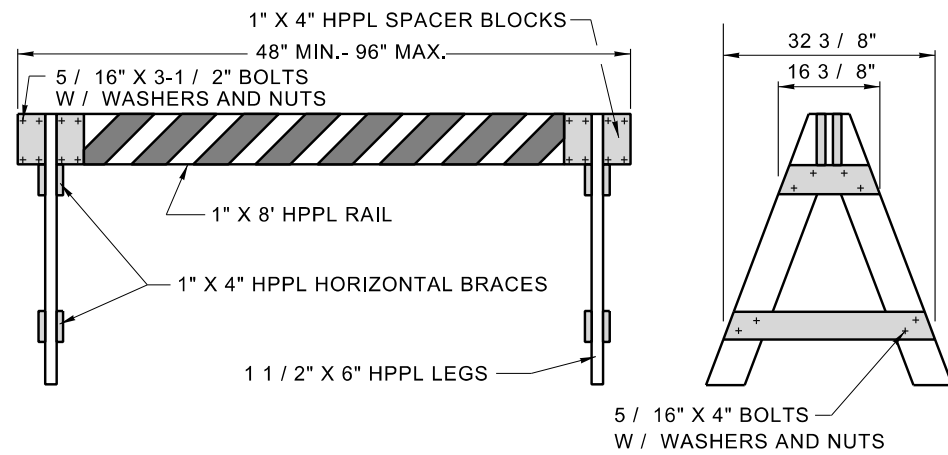

- 1.) Only the following Type I barricade shall be used in the City of San Antonio Right-Of-Way:
 - A. 1" x 8" plastic rail with 2" x 6" wooden legs.
 - B. 1" x 8" wooden rail with plastic legs.
 - C. 1" x 8" wooden rail with 2" x 6" wood legs.
 - D. No screws allowed for assembly of A-legs or rail.
 - E. Warning lights will be used as directed by the Traffic Engineer.
 - F. All Type I (4') barricades will be a minimum of 36" high and 60" wide. (For Construction Use Only)
 - G. All Type I (8') barricades with wooden legs shall be 2" X 6" wood only.
 - H. All Type I (4') barricades with wooden legs shall be 1" X 8" wood only.
- 2.) Type I Barricades shall not be used for partial and total street closures in construction work zones. Only Type III barricades shall be used for this purpose.
- 3.) Warning lights shall not be mounted on Type I barricades.

(See TxDOT BC-03 Sheets for specific construction information)

CONES

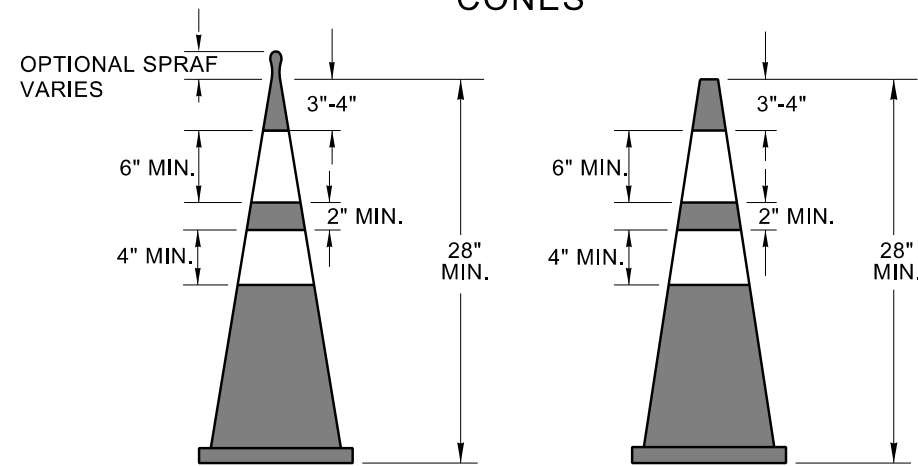

- 1.) Base for 28" high cones must weigh at least 9.5 lbs.
- 2.) Night time cones must have reflective collars.

(See TxDOT BC-03 Sheets for specific construction information)

Type III BARRICADE

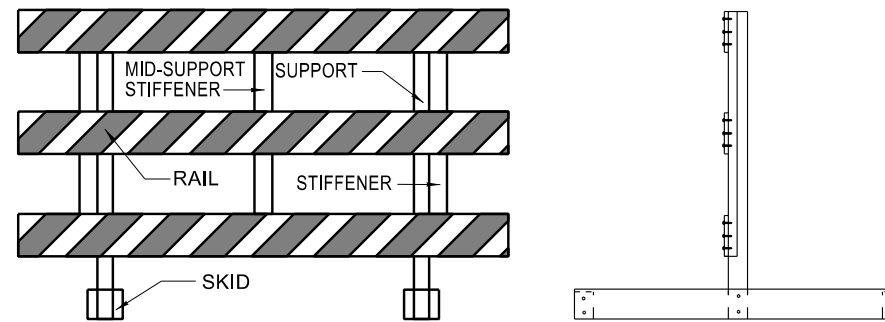

- 1.) Only the following Type III barricade shall be used in the City of San Antonio Right-Of-Way.
 - A. Hollow polyvinyl or fiberglass tubing post with 1" X 8" wooden rails.
 - B. Hollow polyvinyl or fiberglass tubing post with plastic rails.
 - C. Skids must be wood or solid plastic only.
 - D. Warning lights shall not be mounted on Type III barricades.

(See TxDOT BC-03 Sheets for specific construction information)

TEMPORARY MARKINGS

- 1.) Solid double yellow painted lines shall be installed for temporary division of traffic or construction duration longer than five (5) days, with repainting to occur once monthly or at the discretion of the Traffic Engineer. (All cost of upkeep will be at the contractor's expense.)
- 2.) Solid double yellow tabs, or V/P panels shall be installed for temporary division of traffic for construction duration less than five (5) days, with re-tapping to occur at the discretion of the Traffic Engineer.
 NAILS SHALL NOT BE USED TO FIX TABS TO CEMENT OR BASE
 (All cost of upkeep will be at the contractor's expense.)

(See TxDOT BC-03 Sheets for specific construction information.)

TEMPORARY CONCRETE BARRIER

- 1.) All concrete barriers placed on City R.O.W. shall be low profile.
- 2.) No high profile barriers will be allowed.
- 3.) Reflectors will be required on each concrete barrier.

(See TxDOT BC-03 Sheets for specific construction information)

PLASTIC DRUMS

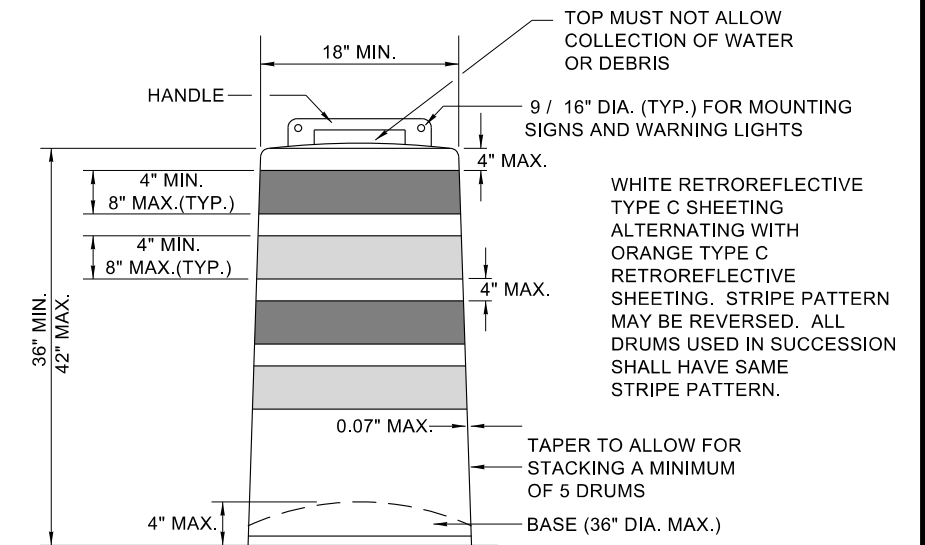

- 1.) Drums and all related items shall comply with the requirements of the current version of the "Texas Manual on Uniform Traffic Control Devices" (TMUTCD) and the "Compliant Work Zone Traffic Control Devices List" (CWZTCD).
- 2.) Drums, bases, and related materials shall exhibit good workmanship and shall be free from objectionable marks or defects that would adversely affect their appearance or serviceability.
- 3.) The Engineer/Inspector shall provide written notice to the Contractor regarding the replacement of drums or other traffic control devices. The Contractor shall have a maximum of 24 hours to replace any plastic drums or other traffic control devices identified for replacement by the Engineer/Inspector. The replacement device must be an approved device.
- 4.) Each drum must have a 40 lb. rubber or plastic snap on.
- 5.) No signs larger than 18" X 24" will be allowed to be mounted on plastic drums.
- 6.) No warning lights will be allowed to be mounted on plastic barrels.
- 7.) In lieu of a warning light, a yellow reflector will be acceptable.

(See TxDOT BC-03 Sheets for specific construction information)

OCTOBER 2018

CITY OF SAN ANTONIO
DEPARTMENT OF PUBLIC WORKS

TRAFFIC STANDARDS
BARRICADE AND CONSTRUCTION STANDARDS
SHEET 3 OF 4

THE ORIGINAL OF THIS DRAWING WAS SIGNED AND SEALED BY JOHN D. FRIEBELE, #46394 ON 06-20-05 AND IS ON FILE WITH THE TRAFFIC ENGINEERING DIVISION OF THE PUBLIC WORKS DEPARTMENT, CITY OF SAN ANTONIO.

70% SUBMITTAL	PROJECT NO.: 23-03763	DATE: 1/20/2023
DRWN. BY: A.F.G.	DSGN. BY: E.N.M.	CHKD. BY: J.D.F./E.N.M.
		SHEET NO.: 75 OF 521

SIGNS

- 1.) A maximum of two signs can be mounted on any one Long / Intermediate Term Stationary Portable Sign Support.
- 2.) 48" X 48" signs shall be mounted separately on the Long / Intermediate Term Stationary Portable Sign Support.
- 3.) For Short Term Stationary Portable Sign Support the distance from the bottom of the vinyl sign to the exiting ground must be one (1) foot.
- 4.) Long / Intermediate Term Stationary Portable Signs must be made of wood or plastic only.
- 5.) No signs shall be mounted to any Type I, Type III, or folding barricades.
- 6.) Signs shall be mounted only on TxDOT approved sign supports.
- 7.) Detour signs will be mounted on single "D" legs w / 7' clearance from the bottom of the sign.
- 8.) **WORK DURATION TERMINOLOGY**
 Long Term Stationary = occupies a location 3 or more days.
 Intermediate-Term Stationary = occupies a location for overnight to 3 days.
 Short Term Stationary = daylight work that occupies a location from 1 to 12 hours.
 Short Duration = occupies a location up to 1 hour.
- 9.) Signs shall adhere to the following requirements:
 - Signs placed on plastic barrels or drums shall be made of ABS plastic or plywood.
 - Signs placed on skids shall be made of plywood or aluminum.
 - Aluminum signs shall have a minimum thickness of 0.08".
 - Plywood signs shall have a minimum thickness of 1 / 2".
 - ABS Plastic signs shall have a minimum thickness of 0.13".
 - Plastic signs cannot exceed 18" by 24" in size and shall be reinforced with 2" wide, 0.08" thick aluminum slats, as depicted below:

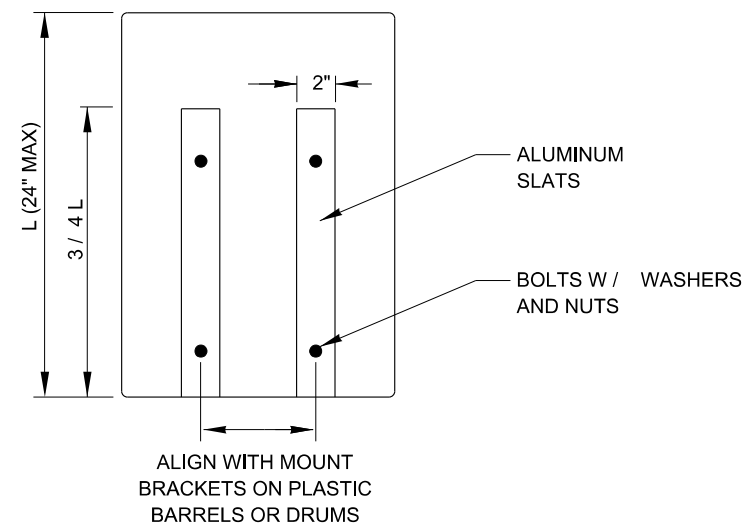

- No other material shall be accepted without the express written approval of the Traffic Engineer.

(See TxDOT BC-03 Sheets for specific construction information.)

LONG TERM / INTERMEDIATE TERM SIGN SUPPORT

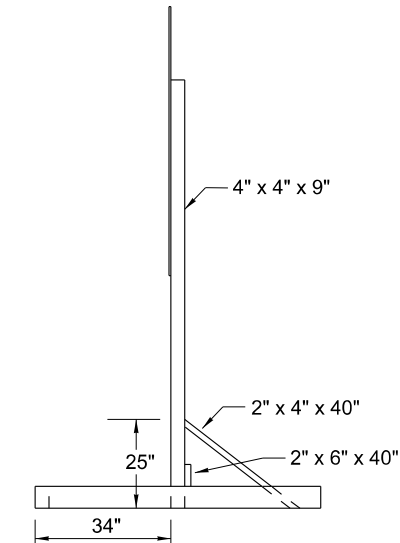
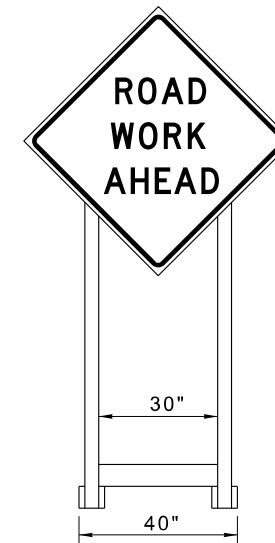

- 1.) 48" X48" signs must be mounted independently.
- 2.) A maximum of two signs can be mounted on any one long term / intermediate sign support.
- 3.) Sand bag all sign supports.
- 4.) Distance from the bottom of the sign to the existing ground shall be 7'.
- 5.) Distance from the header barricade rail to the face of the sign panel shall be 2' min. and 10' max.
- 6.) Steel tripods shall not be allowed.

(See TxDOT BC-03 Sheets for specific construction information)

THE ORIGINAL OF THIS DRAWING WAS SIGNED AND SEALED BY JOHN D. FRIEBELE, #46394 ON 06-20-05 AND IS ON FILE WITH THE TRAFFIC ENGINEERING DIVISION OF THE PUBLIC WORKS DEPARTMENT, CITY OF SAN ANTONIO.

JUNE 2005			
CITY OF SAN ANTONIO DEPARTMENT OF PUBLIC WORKS			
TRAFFIC STANDARDS BARRICADE AND CONSTRUCTION STANDARDS SHEET 4 OF 4			
70% SUBMITTAL	PROJECT NO.: 23-03763	DATE: 1/20/2023	
DRWN. BY: A.F.G.	DSGN. BY: E.N.M.	CHKD. BY: J.D.F./ E.N.M.	SHEET NO.: 76 OF 521

DISCLAIMER: This standard is governed by the "Texas Engineering Practice Act". No warranty of any kind is made by TxDOT for any purpose whatsoever. TxDOT assumes no responsibility for the conversion of this standard to other formats or for incorrect results or damages resulting from its use.

DATE: 1/20/2023 7:07:14 PM
 FILE: K:\COSA_Doloresa\STANDARDS\TCP\bc-21.dgn

BARRICADE AND CONSTRUCTION (BC) STANDARD SHEETS GENERAL NOTES:

1. The Barricade and Construction Standard Sheets (BC sheets) are intended to show typical examples for placement of temporary traffic control devices, construction pavement markings, and typical work zone signs. The information contained in these sheets meet or exceed the requirements shown in the "Texas Manual on Uniform Traffic Control Devices" (TMUTCD).
2. The development and design of the Traffic Control Plan (TCP) is the responsibility of the Engineer.
3. The Contractor may propose changes to the TCP that are signed and sealed by a licensed professional engineer for approval. The Engineer may develop, sign and seal Contractor proposed changes.
4. The Contractor is responsible for installing and maintaining the traffic control devices as shown in the plans. The Contractor may not move or change the approximate location of any device without the approval of the Engineer.
5. Geometric design of lane shifts and detours should, when possible, meet the applicable design criteria contained in manuals such as the American Association of State Highway and Transportation Officials (AASHTO), "A Policy on Geometric Design of Highways and Streets," the TxDOT "Roadway Design Manual" or engineering judgment.
6. When projects abut, the Engineer(s) may omit the END ROAD WORK, TRAFFIC FINES DOUBLE, and other advance warning signs if the signing would be redundant and the work areas appear continuous to the motorists. If the adjacent project is completed first, the Contractor shall erect the necessary warning signs as shown on these sheets, the TCP sheets or as directed by the Engineer. The BEGIN ROAD WORK NEXT X MILES sign shall be revised to show appropriate work zone distance.
7. The Engineer may require duplicate warning signs on the median side of divided highways where median width will permit and traffic volumes justify the signing.
8. All signs shall be constructed in accordance with the details found in the "Standard Highway Sign Designs for Texas," latest edition. Sign details not shown in this manual shall be shown in the plans or the Engineer shall provide a detail to the Contractor before the sign is manufactured.
9. The temporary traffic control devices shown in the illustrations of the BC sheets are examples. As necessary, the Engineer will determine the most appropriate traffic control devices to be used.
10. Where highway construction or maintenance work is being undertaken, other than mobile operations as defined by the Texas Manual on Uniform Traffic Control Devices, CSJ limit signs are required. CSJ limit signs are shown on BC(2). The OBEY WARNING SIGNS STATE LAW sign, STAY ALERT TALK OR TEXT LATER and the WORK ZONE TRAFFIC FINES DOUBLE sign with plaque shall be erected in advance of the CSJ limits. The BEGIN ROAD WORK NEXT X MILES, CONTRACTOR and END ROAD WORK signs shall be erected at or near the CSJ limits. For mobile operations, CSJ limit signs are not required.
11. Traffic control devices should be in place only while work is actually in progress or a definite need exists.
12. The Engineer has the final decision on the location of all traffic control devices.
13. Inactive equipment and work vehicles, including workers' private vehicles must be parked away from travel lanes. They should be as close to the right-of-way line as possible, or located behind a barrier or guardrail, or as approved by the Engineer.

WORKER SAFETY NOTES:

1. Workers on foot who are exposed to traffic or to construction equipment within the right-of-way shall wear high-visibility safety apparel meeting the requirements of ISEA "American National Standard for High-Visibility Apparel," or equivalent revisions, and labeled as ANSI 107-2004 standard performance for Class 2 or 3 risk exposure. Class 3 garments should be considered for high traffic volume work areas or night time work.
2. Except in emergency situations, flagger stations shall be illuminated when flagging is used at night.

COMPLIANT WORKZONE TRAFFIC CONTROL DEVICES

1. Only pre-qualified products shall be used. The "Compliant Work Zone Traffic Control Devices List" (CWZTCD) describes pre-qualified products and their sources.
2. Work zone traffic control devices shall be compliant with the Manual for Assessing safety Hardware (MASH).

THE DOCUMENTS BELOW CAN BE FOUND ON-LINE AT http://www.txdot.gov
COMPLIANT WORK ZONE TRAFFIC CONTROL DEVICES LIST (CWZTCD)
DEPARTMENTAL MATERIAL SPECIFICATIONS (DMS)
MATERIAL PRODUCER LIST (MPL)
ROADWAY DESIGN MANUAL - SEE "MANUALS (ONLINE MANUALS)"
STANDARD HIGHWAY SIGN DESIGNS FOR TEXAS (SHSD)
TEXAS MANUAL ON UNIFORM TRAFFIC CONTROL DEVICES (TMUTCD)
TRAFFIC ENGINEERING STANDARD SHEETS

SHEET 1 OF 12



**BARRICADE AND CONSTRUCTION
GENERAL NOTES
AND REQUIREMENTS**

BC (1) - 21

FILE:	bc-21.dgn	DN:	TxDOT	CK:	TxDOT	DW:	TxDOT	CK:	TxDOT
© TxDOT	November 2002	CONT	SECT	JOB	HIGHWAY				
REVISIONS		DIST		COUNTY	SHEET NO.				
4-03	7-13			BEXAR	77				
9-07	8-14								
5-10	5-21								

DISCLAIMER: The use of this standard is governed by the "Texas Engineering Practice Act". No warranty of any kind is made by TxDOT for any purpose whatsoever. TxDOT assumes no responsibility for the conversion of this standard to other formats or for incorrect results or damages resulting from its use.

TYPICAL LOCATION OF CROSSROAD SIGNS

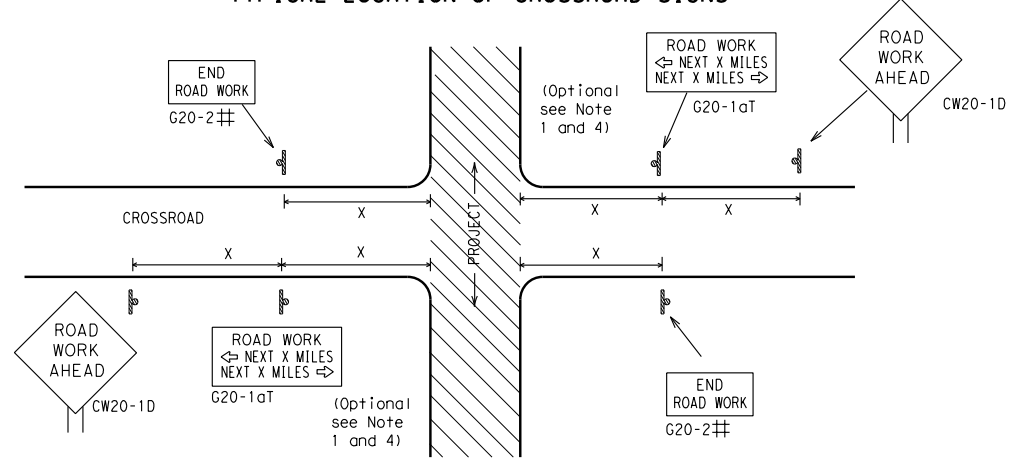

- ## May be mounted on back of "ROAD WORK AHEAD" (CW20-1D) sign with approval of Engineer. (See note 2 below)
- The typical minimum signing on a crossroad approach should be a "ROAD WORK AHEAD" (CW20-1D) sign and a (G20-2) "END ROAD WORK" sign, unless noted otherwise in plans.
 - The Engineer may use the reduced size 36" x 36" ROAD WORK AHEAD (CW20-1D) sign mounted back to back with the reduced size 36" x 18" "END ROAD WORK" (G20-2) sign on low volume crossroads (see Note 4 under "Typical Construction Warning Sign Size and Spacing"). See the "Standard Highway Sign Designs for Texas" manual for sign details. The Engineer may omit the advance warning signs on low volume crossroads. The Engineer will determine whether a road is low volume as per TMUTCD Part 5. This information shall be shown in the plans.
 - Based on existing field conditions, the Engineer/Inspector may require additional signs such as FLAGGER AHEAD, LOOSE GRAVEL, or other appropriate signs. When additional signs are required, these signs will be considered part of the minimum requirements. The Engineer/Inspector will determine the proper location and spacing of any sign not shown on the BC sheets, Traffic Control Plan sheets or the Work Zone Standard Sheets.
 - The "ROAD WORK NEXT X MILES" (G20-1aT) sign shall be required at high volume crossroads to advise motorists of the length of construction in either direction from the intersection. The Engineer will determine whether a roadway is considered high volume.
 - Additional traffic control devices may be shown elsewhere in the plans for higher volume crossroads.
 - When work occurs in the intersection area, appropriate traffic control devices, as shown elsewhere in the plans or as determined by the Engineer/Inspector, shall be in place.

T-INTERSECTION

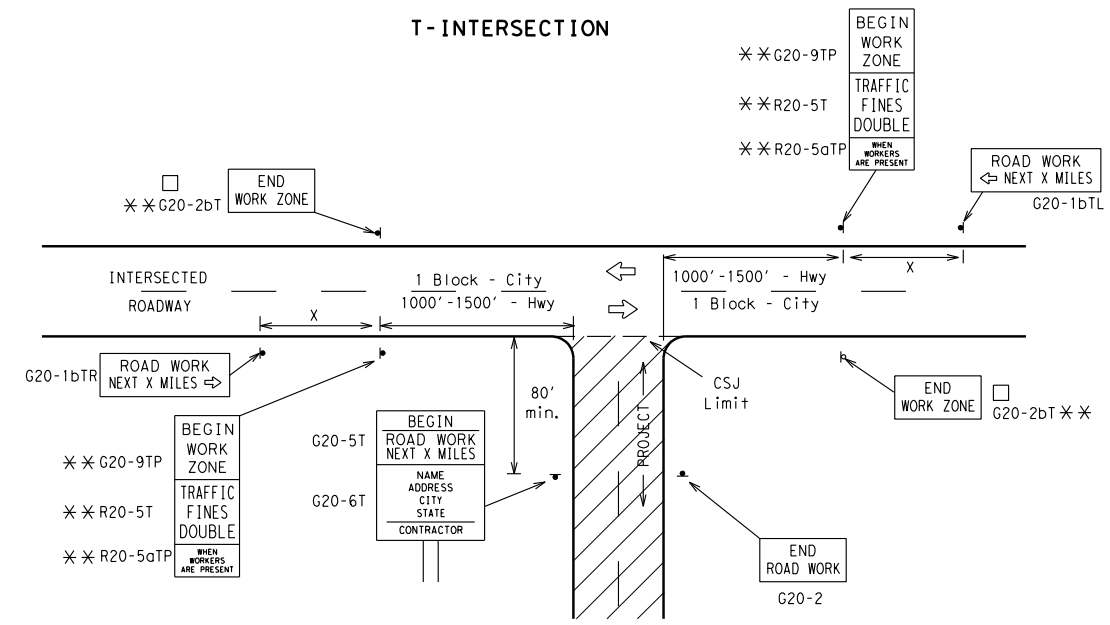

CSJ LIMITS AT T-INTERSECTION

- The Engineer will determine the types and location of any additional traffic control devices, such as a flagger and accompanying signs, or other signs, that should be used when work is being performed at or near an intersection.
- If construction closes the road at a T-intersection, the Contractor shall place the "CONTRACTOR NAME" (G20-6T) sign behind the Type 3 Barricades for the road closure (see BC(10) also). The "ROAD WORK NEXT X MILES" left arrow (G20-1bTL) and "ROAD WORK NEXT X MILES" right arrow (G20-1bTR) signs shall be replaced by the detour signing called for in the plans.

TYPICAL CONSTRUCTION WARNING SIGN SIZE AND SPACING^{1,5,6}

Sign Number or Series	SIZE		SPACING	
	Conventional Road	Expressway/Freeway	Posted Speed MPH	Sign Δ Spacing "X" Feet (Apprx.)
CW20 ⁴	48" x 48"	48" x 48"	30	120
CW21			35	160
CW22			40	240
CW23			45	320
CW25			50	400
CW1, CW2, CW7, CW8, CW9, CW11, CW14	36" x 36"	48" x 48"	55	500 ²
CW3, CW4, CW5, CW6, CW8-3, CW10, CW12	48" x 48"	48" x 48"	60	600 ²
			65	700 ²
			70	800 ²
			75	900 ²
			80	1000 ²
			*	* ³

* For typical sign spacings on divided highways, expressways and freeways, see Part 6 of the "Texas Manual on Uniform Traffic Control Devices" (TMUTCD) typical application diagrams or TCP Standard Sheets.

△ Minimum distance from work area to first Advance Warning sign nearest the work area and/or distance between each additional sign.

GENERAL NOTES

- Special or larger size signs may be used as necessary.
- Distance between signs should be increased as required to have 1500 feet advance warning.
- Distance between signs should be increased as required to have 1/2 mile or more advance warning.
- 36" x 36" "ROAD WORK AHEAD" (CW20-1D) signs may be used on low volume crossroads at the discretion of the Engineer as per TMUTCD Part 5. See Note 2 under "Typical Location of Crossroad Signs".
- Only diamond shaped warning sign sizes are indicated.
- See sign size listing in "TMUTCD", Sign Appendix or the "Standard Highway Sign Designs for Texas" manual for complete list of available sign design sizes.

WORK AREAS IN MULTIPLE LOCATIONS WITHIN CSJ LIMITS

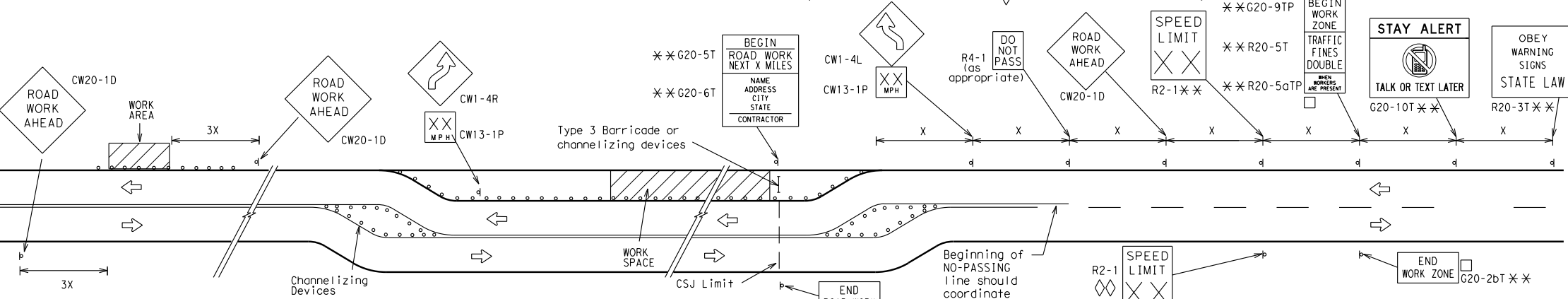

When extended distances occur between minimal work spaces, the Engineer/Inspector should ensure additional "ROAD WORK AHEAD" (CW20-1D) signs are placed in advance of these work areas to remind drivers they are still within the project limits. See the applicable TCP sheets for exact location and spacing of signs and channelizing devices.

SAMPLE LAYOUT OF SIGNING FOR WORK BEGINNING DOWNSTREAM OF THE CSJ LIMITS

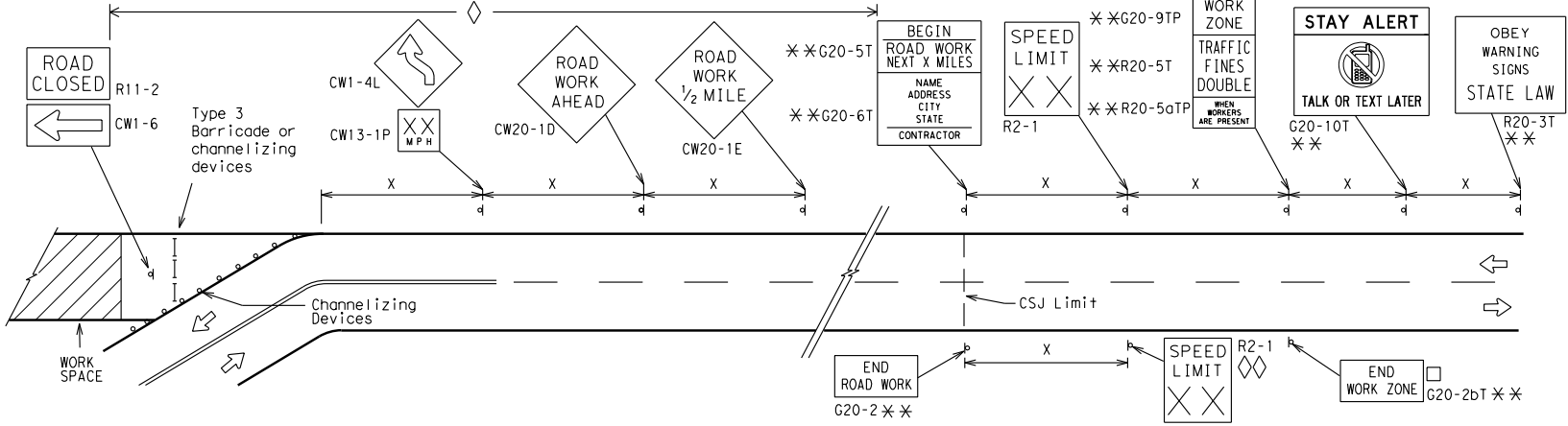

SAMPLE LAYOUT OF SIGNING FOR WORK BEGINNING AT THE CSJ LIMITS

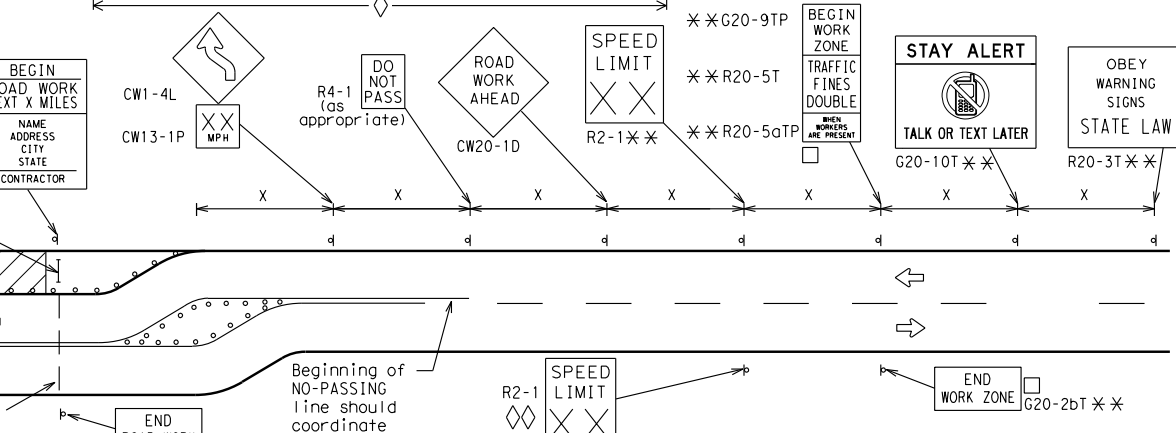

NOTES

- The Contractor shall determine the appropriate distance to be placed on the G20-1 series signs and "BEGIN ROAD WORK NEXT X MILES" (G20-5T) sign for each specific project. This distance shall replace the "X" and shall be rounded to the nearest whole mile with the approval of the Engineer. No decimals shall be used.
- The "BEGIN WORK ZONE" (G20-9TP) and "END WORK ZONE" (G20-2bT) shall be used as shown on the sample layout when advance signs are required outside the CSJ Limits. They inform the motorist of entering or leaving a part of the work zone lying outside the CSJ Limits where traffic fines may double if workers are present.
 - ** CSJ limit signing is required for highway construction and maintenance work, with the exception of mobile operations.
 - ◇ Area for placement of "ROAD WORK AHEAD" (CW20-1D) sign and other signs or devices as called for on the Traffic Control Plan.
 - ◇◇ Contractor will install a regulatory speed limit sign at the end of the work zone.

LEGEND	
—	Type 3 Barricade
○ ○ ○	Channelizing Devices
■	Sign
X	See Typical Construction Warning Sign Size and Spacing chart or the TMUTCD for sign spacing requirements.

SHEET 2 OF 12



BARRICADE AND CONSTRUCTION PROJECT LIMIT

BC (2) - 21

FILE: bc-21.dgn	DN: TxDOT	CK: TxDOT	DW: TxDOT	CK: TxDOT
© TxDOT November 2002	CONT	SECT	JOB	HIGHWAY
REVISIONS				COSA
9-07 8-14	DIST	COUNTY		SHEET NO.
7-13 5-21		BEXAR		78

DATE: 1/20/2023 7:07:14 PM
 FILE: K:\COSA\DoI\os\STANDARDS\TCP\bc-21.dgn

DISCLAIMER: The use of this standard is governed by the "Texas Engineering Practice Act". No warranty of any kind is made by TxDOT for any purpose whatsoever. TxDOT assumes no responsibility for the conversion of this standard to other formats or for incorrect results or damages resulting from its use.

TYPICAL MINIMUM CLEARANCES FOR LONG TERM AND INTERMEDIATE TERM SIGNS

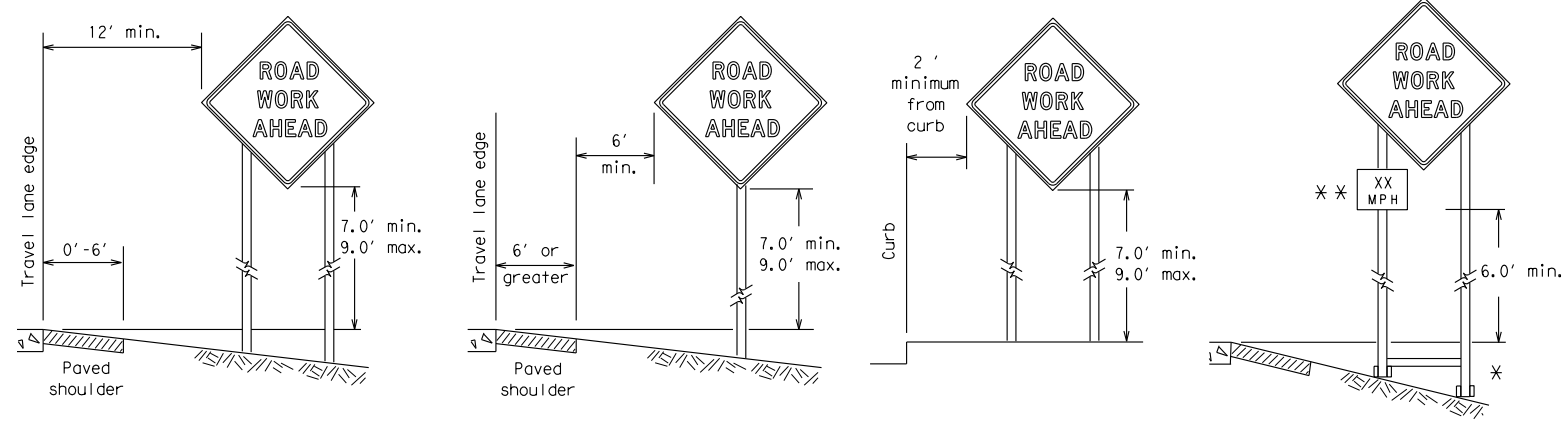

* When placing skid supports on unlevel ground, the leg post lengths must be adjusted so the sign appears straight and plumb. Objects shall NOT be placed under skids as a means of leveling.

** When plaques are placed on dual-leg supports, they should be attached to the upright nearest the travel lane. Supplemental plaques (advisory or distance) should not cover the surface of the parent sign.

ATTACHMENT FOR SIGN SUPPORTS

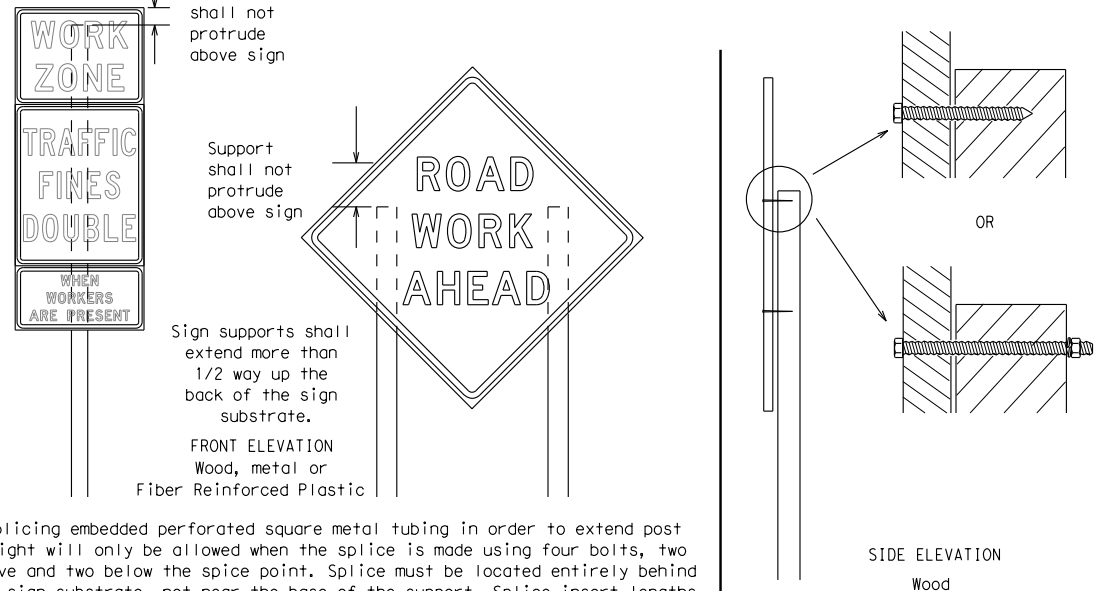

Attachment to wooden supports will be by bolts and nuts or screws. Use TxDOT's or manufacturer's recommended procedures for attaching sign substrates to other types of sign supports

Nails shall NOT be allowed. Each sign shall be attached directly to the sign support. Multiple signs shall not be joined or spliced by any means. Wood supports shall not be extended or repaired by splicing or other means.

Splicing embedded perforated square metal tubing in order to extend post height will only be allowed when the splice is made using four bolts, two above and two below the splice point. Splice must be located entirely behind the sign substrate, not near the base of the support. Splice insert lengths should be at least 5 times nominal post size, centered on the splice and of at least the same gauge material.

STOP/SLOW PADDLES

- STOP/SLOW paddles are the primary method to control traffic by flaggers. The STOP/SLOW paddle size should be 24" x 24".
- STOP/SLOW paddles shall be retroreflective when used at night.
- STOP/SLOW paddles may be attached to a staff with a minimum length of 6' to the bottom of the sign.
- Any lights incorporated into the STOP or SLOW paddle faces shall only be as specifically described in Section 6E.03 Hand Signaling Devices in the TMUTCD.

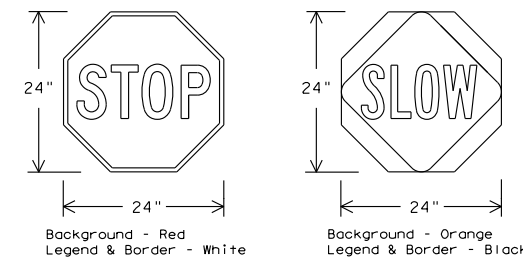

SHEETING REQUIREMENTS (WHEN USED AT NIGHT)		
USAGE	COLOR	SIGN FACE MATERIAL
BACKGROUND	RED	TYPE B OR C SHEETING
BACKGROUND	ORANGE	TYPE B _{FL} OR C _{FL} SHEETING
LEGEND & BORDER	WHITE	TYPE B OR C SHEETING
LEGEND & BORDER	BLACK	ACRYLIC NON-REFLECTIVE FILM

CONTRACTOR REQUIREMENTS FOR MAINTAINING PERMANENT SIGNS WITHIN THE PROJECT LIMITS

- Permanent signs are used to give notice of traffic laws or regulations, call attention to conditions that are potentially hazardous to traffic operations, show route designations, destinations, directions, distances, services, points of interest, and other geographical, recreational, specific service (LOGO), or cultural information. Drivers proceeding through a work zone need the same, if not better route guidance as normally installed on a roadway without construction.
- When permanent regulatory or warning signs conflict with work zone conditions, remove or cover the permanent signs until the permanent sign message matches the roadway condition. For details for covering large guide signs see the TS-CD standard.
- When existing permanent signs are moved and relocated due to construction purposes, they shall be visible to motorists at all times.
- If existing signs are to be relocated on their original supports, they shall be installed on crashworthy bases as shown on the SMD Standard sheets. The signs shall meet the required mounting heights shown on the BC Sheets or the SMD Standards. This work should be paid for under the appropriate pay item for relocating existing signs.
- If permanent signs are to be removed and relocated using temporary supports, the Contractor shall use crashworthy supports as shown on the BC standard sheets, TLRs standard sheets or the CWZTCD list. The signs shall meet the required mounting heights shown on the BC, or the SMD standard sheets during construction. This work should be paid for under the appropriate pay item for relocating existing signs.
- Any sign or traffic control device that is struck or damaged by the Contractor or his/her construction equipment shall be replaced as soon as possible by the Contractor to ensure proper guidance for the motorists. This will be subsidiary to Item 502.

GENERAL NOTES FOR WORK ZONE SIGNS

- Contractor shall install and maintain signs in a straight and plumb condition and/or as directed by the Engineer.
- Wooden sign posts shall be painted white.
- Barricades shall NOT be used as sign supports.
- All signs shall be installed in accordance with the plans or as directed by the Engineer. Signs shall be used to regulate, warn, and guide the traveling public safely through the work zone.
- The Contractor may furnish either the sign design shown in the plans or in the "Standard Highway Sign Designs for Texas" (SHSD). The Engineer/Inspector may require the Contractor to furnish other work zone signs that are shown in the TMUTCD but may have been omitted from the plans. Any variation in the plans shall be documented by written agreement between the Engineer and the Contractor's Responsible Person. All changes must be documented in writing before being implemented. This can include documenting the changes in the Inspector's TxDOT diary and having both the Inspector and Contractor initial and date the agreed upon changes.
- The Contractor shall furnish sign supports listed in the "Compliant Work Zone Traffic Control Device List" (CWZTCD) for small roadside signs. Supports for temporary large roadside signs shall meet the requirements detailed on the Temporary Large Roadside Signs (TLRS) standard sheets. The Contractor shall install the sign support in accordance with the manufacturer's recommendations. If there is a question regarding installation procedures, the Contractor shall furnish the Engineer a copy of the manufacturer's installation recommendations so the Engineer can verify the correct procedures are being followed.
- The Contractor is responsible for installing signs on approved supports and replacing signs with damaged or cracked substrates and/or damaged or marred reflective sheeting as directed by the Engineer/Inspector.
- Identification markings may be shown only on the back of the sign substrate. The maximum height of letters and/or company logos used for identification shall be 1 inch.
- The Contractor shall replace damaged wood posts. New or damaged wood sign posts shall not be spliced.

DURATION OF WORK (as defined by the "Texas Manual on Uniform Traffic Control Devices" Part 6)

- The types of sign supports, sign mounting height, the size of signs, and the type of sign substrates can vary based on the type of work being performed. The Engineer is responsible for selecting the appropriate size sign for the type of work being performed. The Contractor is responsible for ensuring the sign support, sign mounting height and substrate meets manufacturer's recommendations in regard to crashworthiness and duration of work requirements.
 - Long-term stationary - work that occupies a location more than 3 days.
 - Intermediate-term stationary - work that occupies a location more than one daylight period up to 3 days, or nighttime work lasting more than one hour.
 - Short-term stationary - daytime work that occupies a location for more than 1 hour in a single daylight period.
 - Short, duration - work that occupies a location up to 1 hour.
 - Mobile - work that moves continuously or intermittently (stopping for up to approximately 15 minutes.)

SIGN MOUNTING HEIGHT

- The bottom of Long-term/Intermediate-term signs shall be at least 7 feet, but not more than 9 feet, above the paved surface, except as shown for supplemental plaques mounted below other signs.
- The bottom of Short-term/Short Duration signs shall be a minimum of 1 foot above the pavement surface but no more than 2 feet above the ground.
- Long-term/Intermediate-term Signs may be used in lieu of Short-term/Short Duration signing.
- Short-term/Short Duration signs shall be used only during daylight and shall be removed at the end of the workday or raised to appropriate Long-term/Intermediate sign height.
- Regulatory signs shall be mounted at least 7 feet, but not more than 9 feet, above the paved surface regardless of work duration.

SIZE OF SIGNS

- The Contractor shall furnish the sign sizes shown on BC (2) unless otherwise shown in the plans or as directed by the Engineer.

SIGN SUBSTRATES

- The Contractor shall ensure the sign substrate is installed in accordance with the manufacturer's recommendations for the type of sign support that is being used. The CWZTCD lists each substrate that can be used on the different types and models of sign supports.
- "Mesh" type materials are NOT an approved sign substrate, regardless of the tightness of the weave.
- All wooden individual sign panels fabricated from 2 or more pieces shall have one or more plywood cleat, 1/2" thick by 6" wide, fastened to the back of the sign and extending fully across the sign. The cleat shall be attached to the back of the sign using wood screws that do not penetrate the face of the sign panel. The screws shall be placed on both sides of the splice and spaced at 6" centers. The Engineer may approve other methods of splicing the sign face.

REFLECTIVE SHEETING

- All signs shall be retroreflective and constructed of sheeting meeting the color and retro-reflectivity requirements of DMS-8300 for rigid signs or DMS-8310 for roll-up signs. The web address for DMS specifications is shown on BC(1).
- White sheeting, meeting the requirements of DMS-8300 Type A, shall be used for signs with a white background.
- Orange sheeting, meeting the requirements of DMS-8300 Type B_{FL} or Type C_{FL}, shall be used for rigid signs with orange backgrounds.

SIGN LETTERS

- All sign letters and numbers shall be clear, and open rounded type uppercase alphabet letters as approved by the Federal Highway Administration (FHWA) and as published in the "Standard Highway Sign Design for Texas" manual. Signs, letters and numbers shall be of first class workmanship in accordance with Department Standards and Specifications.

REMOVING OR COVERING

- When sign messages may be confusing or do not apply, the signs shall be removed or completely covered.
- Long-term stationary or intermediate stationary signs installed on square metal tubing may be turned away from traffic 90 degrees when the sign message is not applicable. This technique may not be used for signs installed in the median of divided highways or near any intersections where the sign may be seen from approaching traffic.
- Signs installed on wooden skids shall not be turned at 90 degree angles to the roadway. These signs should be removed or completely covered when not required.
- When signs are covered, the material used shall be opaque, such as heavy mil black plastic, or other materials which will cover the entire sign face and maintain their opaque properties under automobile headlights at night, without damaging the sign sheeting.
- Burlap shall NOT be used to cover signs.
- Duct tape or other adhesive material shall NOT be affixed to a sign face.
- Signs and anchor stubs shall be removed and holes backfilled upon completion of work.

SIGN SUPPORT WEIGHTS

- Where sign supports require the use of weights to keep from turning over, the use of sandbags with dry, cohesionless sand should be used.
- The sandbags will be tied shut to keep the sand from spilling and to maintain a constant weight.
- Rock, concrete, iron, steel or other solid objects shall not be permitted for use as sign support weights.
- Sandbags should weigh a minimum of 35 lbs and a maximum of 50 lbs.
- Sandbags shall be made of a durable material that tears upon vehicular impact. Rubber (such as tire inner tubes) shall NOT be used.
- Rubber ballasts designed for channelizing devices should not be used for ballast on portable sign supports. Sign supports designed and manufactured with rubber bases may be used when shown on the CWZTCD list.
- Sandbags shall only be placed along or laid over the base supports of the traffic control device and shall not be suspended above ground level or hung with rope, wire, chains or other fasteners. Sandbags shall be placed along the length of the skids to weigh down the sign support.
- Sandbags shall NOT be placed under the skid and shall not be used to level sign supports placed on slopes.

FLAGS ON SIGNS

- Flags may be used to draw attention to warning signs. When used, the flag shall be 16 inches square or larger and shall be orange or fluorescent red-orange in color. Flags shall not be allowed to cover any portion of the sign face.



BARRICADE AND CONSTRUCTION TEMPORARY SIGN NOTES

BC (4) - 21

FILE: bc-21.dgn	DN: TxDOT	CK: TxDOT	DW: TxDOT	CK: TxDOT
© TxDOT November 2002	CONT	SECT	JOB	HIGHWAY
REVISIONS				
9-07 8-14				COSA
7-13 5-21				
	DIST	COUNTY	SHEET NO.	
		BEXAR	79	

DATE: 1/20/2023 7:07:15 PM
FILE: K:\COSA\DoI\ososa\STANDARDS\TCP\bc--21.dgn

DISCLAIMER: The use of this standard is governed by the "Texas Engineering Practice Act". No warranty of any kind is made by TxDOT for any purpose whatsoever. TxDOT assumes no responsibility for the conversion of this standard to other formats or for incorrect results or damages resulting from its use.

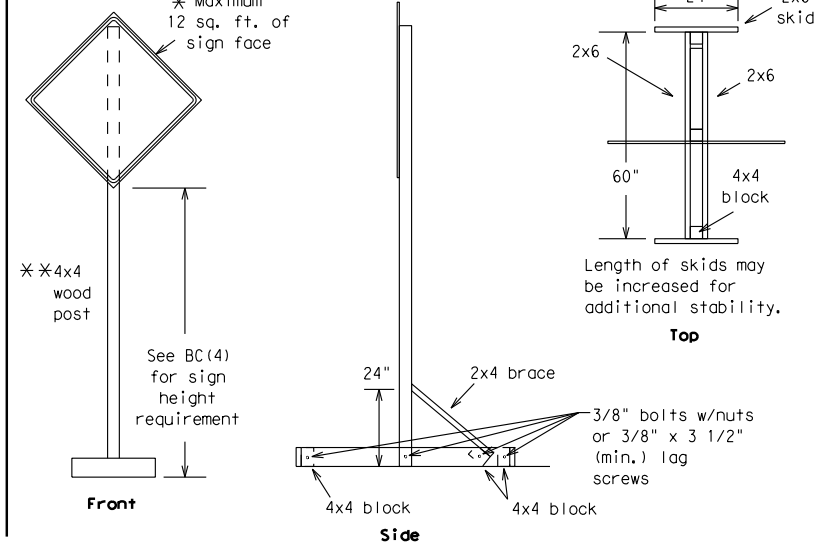
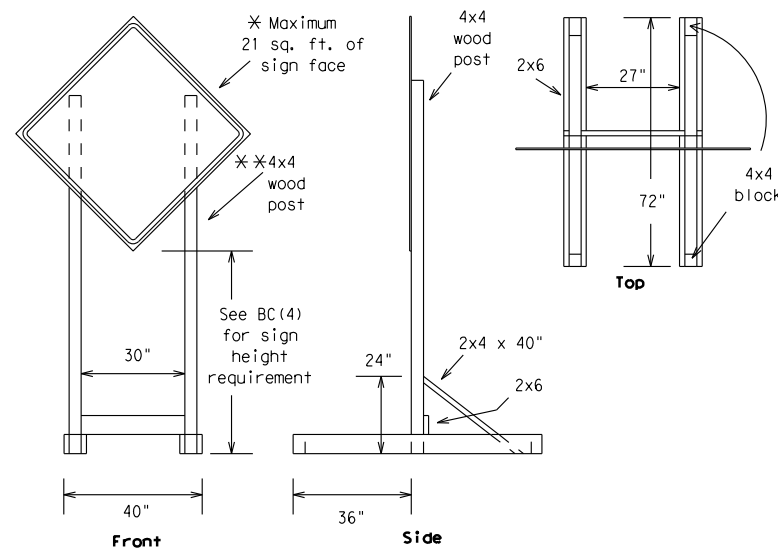

SKID MOUNTED WOOD SIGN SUPPORTS

* LONG/INTERMEDIATE TERM STATIONARY - PORTABLE SKID MOUNTED SIGN SUPPORTS

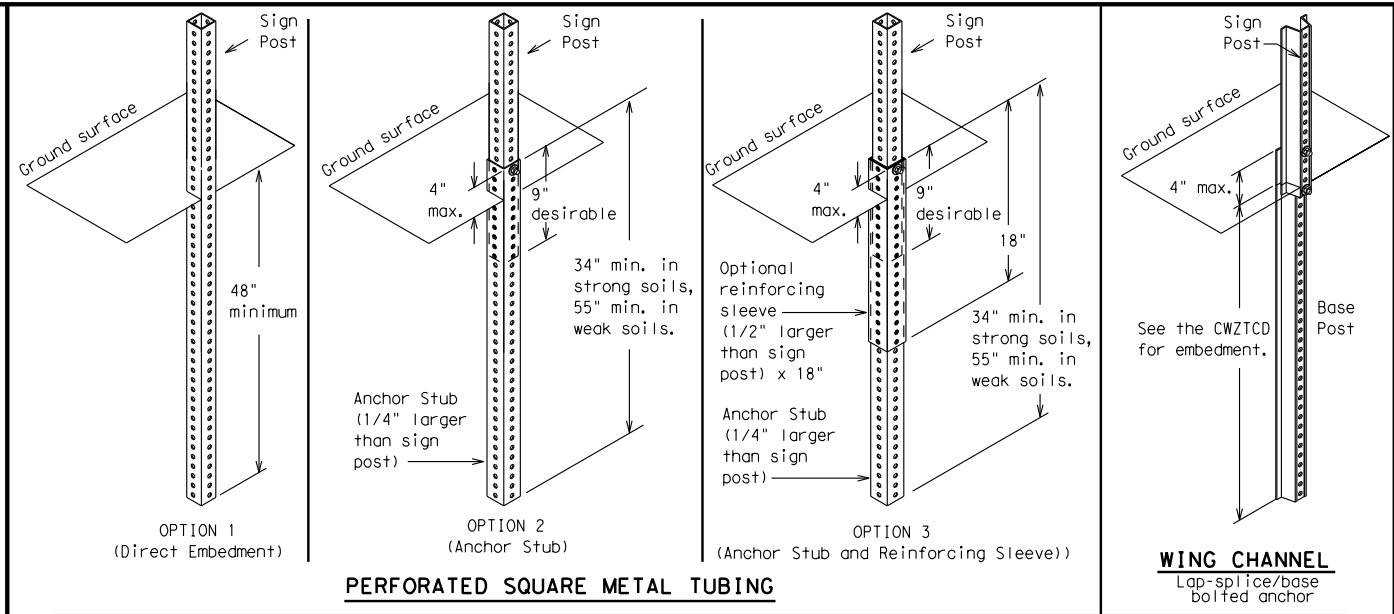

GROUND MOUNTED SIGN SUPPORTS

Refer to the CWZTCD and the manufacturer's installation procedure for each type sign support. The maximum sign square footage shall adhere to the manufacturer's recommendation. Two post installations can be used for larger signs.

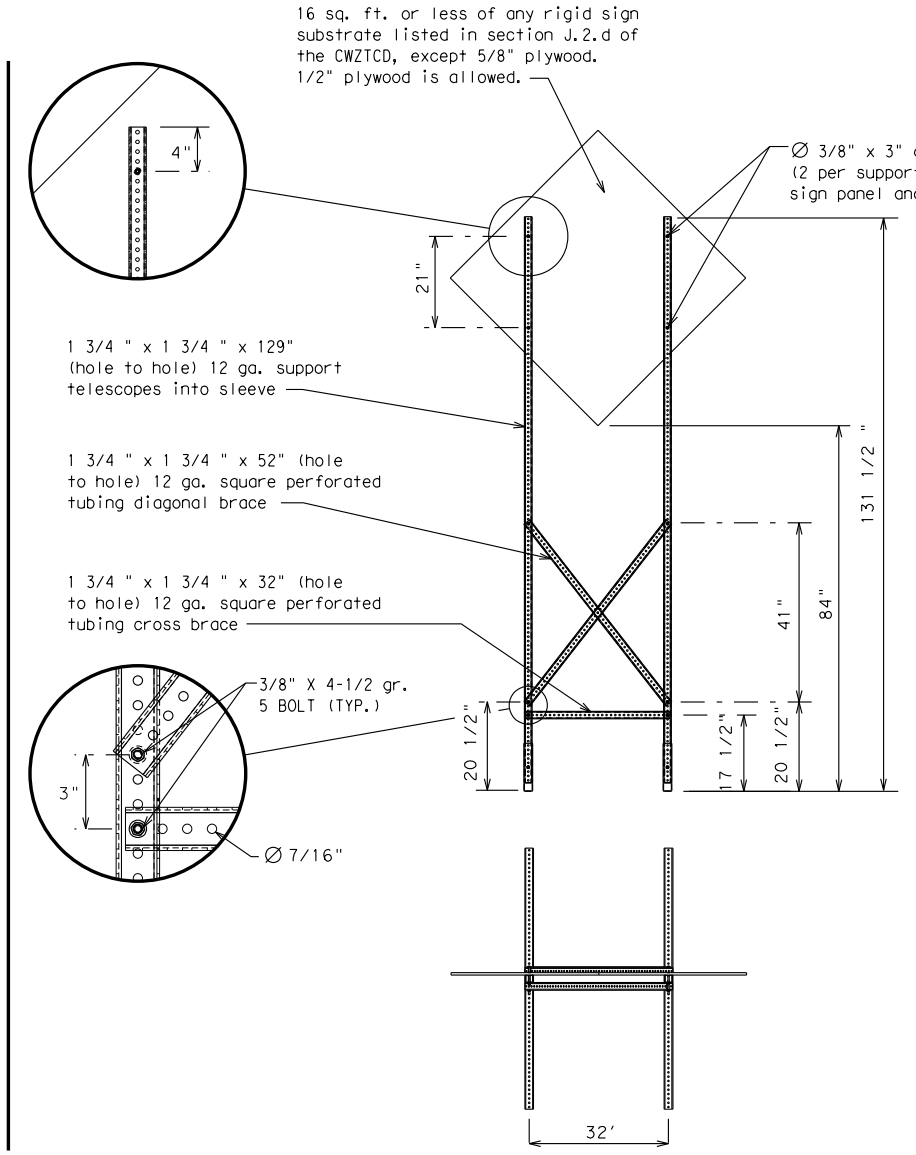
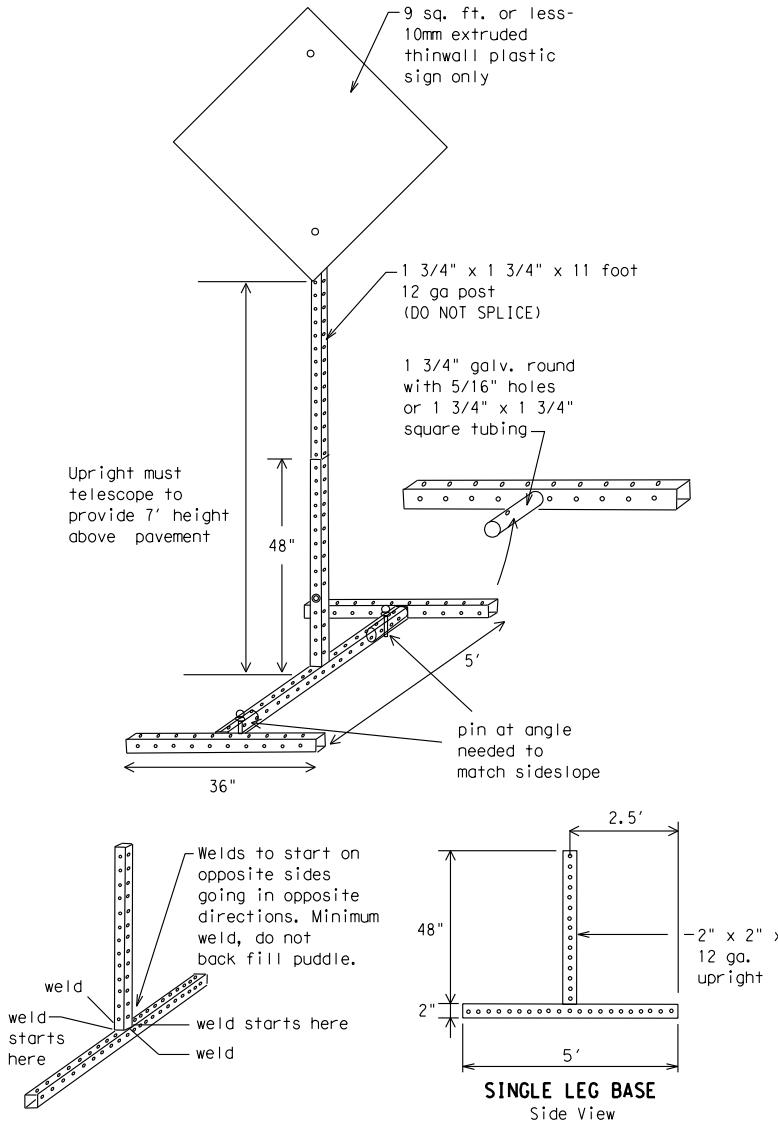

SKID MOUNTED PERFORATED SQUARE STEEL TUBING SIGN SUPPORTS

* LONG/INTERMEDIATE TERM STATIONARY - PORTABLE SKID MOUNTED SIGN SUPPORTS

WEDGE ANCHORS

Both steel and plastic Wedge Anchor Systems as shown on the SMD Standard Sheets may be used as temporary sign supports for signs up to 10 square feet of sign face. They may be set in concrete or in sturdy soils if approved by the Engineer. (See web address for "Traffic Engineering Standard Sheets" on BC(1)).

OTHER DESIGNS

MORE DETAILS OF APPROVED LONG/INTERMEDIATE AND SHORT TERM SUPPORTS CAN BE FOUND ON THE CWZTCD LIST. SEE BC(1) FOR WEBSITE LOCATION.

GENERAL NOTES

- Nails may be used in the assembly of wooden sign supports, but 3/8" bolts with nuts or 3/8" x 3 1/2" lag screws must be used on every joint for final connection.
- No more than 2 sign posts shall be placed within a 7 ft. circle, except for specific materials noted on the CWZTCD List.
- When project is completed, all sign supports and foundations shall be removed from the project site. This will be considered subsidiary to Item 502.

- * See BC(4) for definition of "Work Duration."
- ** Wood sign posts MUST be one piece. Splicing will NOT be allowed. Posts shall be painted white.
- See the CWZTCD for the type of sign substrate that can be used for each approved sign support.

SHEET 5 OF 12



BARRICADE AND CONSTRUCTION TYPICAL SIGN SUPPORT

BC(5) - 21

FILE: bc-21.dgn	DN: TxDOT	CK: TxDOT	DW: TxDOT	CK: TxDOT
© TxDOT November 2002	CONT	SECT	JOB	HIGHWAY
REVISIONS				
9-07 8-14				COSA
7-13 5-21				
	DIST	COUNTY	SHEET NO.	
		BEXAR	80	

DATE: 1/20/2023 7:07:16 PM
FILE: K:\COSA\DoI\os\STANDARDS\TCP\bc-21.dgn

DISCLAIMER: The use of this standard is governed by the "Texas Engineering Practice Act". No warranty of any kind is made by TxDOT for any purpose whatsoever. TxDOT assumes no responsibility for the conversion of this standard to other formats or for incorrect results or damages resulting from its use.

DATE: 1/20/2023 7:07:16 PM
 FILE: K:\COSA\DoI\ososa\STANDARDS\TCP\bc-21.dgn

- Barrier Reflectors shall be pre-qualified, and conform to the color and reflectivity requirements of DMS-8600. A list of prequalified Barrier Reflectors can be found at the Material Producer List web address shown on BC(1).
- Color of Barrier Reflectors shall be as specified in the TMUTCD. The cost of the reflectors shall be considered subsidiary to Item 512.

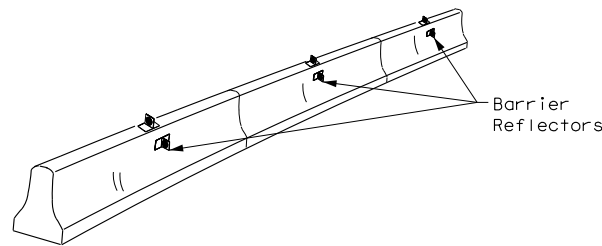

CONCRETE TRAFFIC BARRIER (CTB)

- Where traffic is on one side of the CTB, two (2) Barrier Reflectors shall be mounted in approximately the midsection of each section of CTB. An alternate mounting location is uniformly spaced at one end of each CTB. This will allow for attachment of a barrier grapple without damaging the reflector. The Barrier Reflector mounted on the side of the CTB shall be located directly below the reflector mounted on top of the barrier, as shown in the detail above.
- Where CTB separates two-way traffic, three barrier reflectors shall be mounted on each section of CTB. The reflector unit on top shall have two yellow reflective faces (Bi-Directional) while the reflectors on each side of the barrier shall have one yellow reflective face, as shown in the detail above.
- When CTB separates traffic traveling in the same direction, no barrier reflectors will be required on top of the CTB.
- Barrier Reflector units shall be yellow or white in color to match the edgeline being supplemented.
- Maximum spacing of Barrier Reflectors is forty (40) feet.
- Pavement markers or temporary flexible-reflective roadway marker tabs shall NOT be used as CTB delineation.
- Attachment of Barrier Reflectors to CTB shall be per manufacturer's recommendations.
- Missing or damaged Barrier Reflectors shall be replaced as directed by the Engineer.
- Single slope barriers shall be delineated as shown on the above detail.

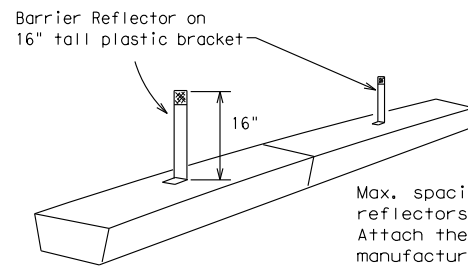

LOW PROFILE CONCRETE BARRIER (LPCB) USED IN WORK ZONES

LPCB is approved for use in work zone locations, where the posted speed is 45mph, or less. See Roadway Standard Sheet LPCB.

Max. spacing of barrier reflectors is 20 feet. Attach the delineators as per manufacturer's recommendations.

LOW PROFILE CONCRETE BARRIER (LPCB)

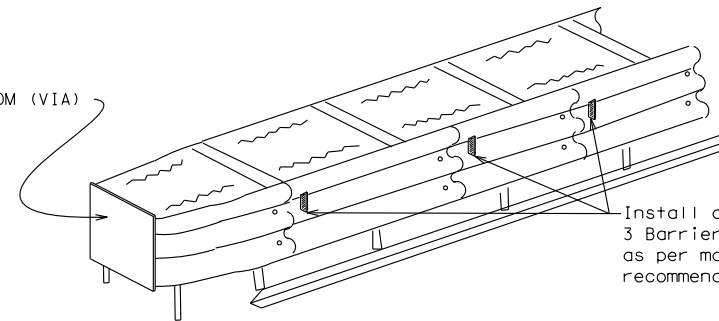

DELINEATION OF END TREATMENTS

END TREATMENTS FOR CTB'S USED IN WORK ZONES

End treatments used on CTB's in work zones shall meet the appropriate crashworthy standards as defined in the Manual for Assessing Safety Hardware (MASH). Refer to the CWZTCD List for approved end treatments and manufacturers.

BARRIER REFLECTORS FOR CONCRETE TRAFFIC BARRIER AND ATTENUATORS

WARNING LIGHTS

- Warning lights shall meet the requirements of the TMUTCD.
- Warning lights shall NOT be installed on barricades.
- Type A-Low Intensity Flashing Warning Lights are commonly used with drums. They are intended to warn of or mark a potentially hazardous area. Their use shall be as indicated on this sheet and/or other sheets of the plans by the designation "FL". The Type A Warning Lights shall not be used with signs manufactured with Type B_{FL} or C_{FL} Sheeting meeting the requirements of Departmental Material Specification DMS-8300.
- Type-C and Type D 360 degree Steady Burn Lights are intended to be used in a series for delineation to supplement other traffic control devices. Their use shall be as indicated on this sheet and/or other sheets of the plans by the designation "SB".
- The Engineer/Inspector or the plans shall specify the location and type of warning lights to be installed on the traffic control devices.
- When required by the Engineer, the Contractor shall furnish a copy of the warning lights certification. The warning light manufacturer will certify the warning lights meet the requirements of the latest ITE Purchase Specifications for Flashing and Steady-Burn Warning Lights.
- When used to delineate curves, Type-C and Type D Steady Burn Lights should only be placed on the outside of the curve, not the inside.
- The location of warning lights and warning reflectors on drums shall be as shown elsewhere in the plans.

WARNING LIGHTS MOUNTED ON PLASTIC DRUMS

- Type A flashing warning lights are intended to warn drivers that they are approaching or are in a potentially hazardous area.
- Type A random flashing warning lights are not intended for delineation and shall not be used in a series.
- A series of sequential flashing warning lights placed on channelizing devices to form a merging taper may be used for delineation. If used, the successive flashing of the sequential warning lights should occur from the beginning of the taper to the end of the merging taper in order to identify the desired vehicle path. The rate of flashing for each light shall be 65 flashes per minute, plus or minus 10 flashes.
- Type C and D steady-burn warning lights are intended to be used in a series to delineate the edge of the travel lane on detours, on lane changes, on lane closures, and on other similar conditions.
- Type A, Type C and Type D warning lights shall be installed at locations as detailed on other sheets in the plans.
- Warning lights shall not be installed on a drum that has a sign, chevron or vertical panel.
- The maximum spacing for warning lights on drums should be identical to the channelizing device spacing.

WARNING REFLECTORS MOUNTED ON PLASTIC DRUMS AS A SUBSTITUTE FOR TYPE C (STEADY BURN) WARNING LIGHTS

- A warning reflector or approved substitute may be mounted on a plastic drum as a substitute for a Type C, steady burn warning light at the discretion of the Contractor unless otherwise noted in the plans.
- The warning reflector shall be yellow in color and shall be manufactured using a sign substrate approved for use with plastic drums listed on the CWZTCD.
- The warning reflector shall have a minimum retroreflective surface area (one-side) of 30 square inches.
- Round reflectors shall be fully reflectorized, including the area where attached to the drum.
- Square substrates must have a minimum of 30 square inches of reflectorized sheeting. They do not have to be reflectorized where it attaches to the drum.
- The side of the warning reflector facing approaching traffic shall have sheeting meeting the color and retroreflectivity requirements for DMS 8300-Type B or Type C.
- When used near two-way traffic, both sides of the warning reflector shall be reflectorized.
- The warning reflector should be mounted on the side of the handle nearest approaching traffic.
- The maximum spacing for warning reflectors should be identical to the channelizing device spacing requirements.

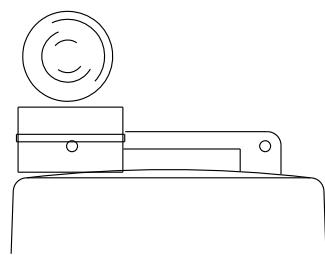

Type C Warning Light or approved substitute mounted on a drum adjacent to the travel way.

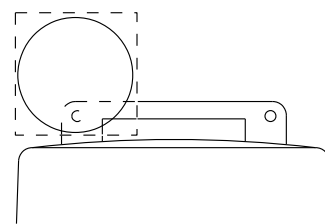

Warning reflector may be round or square. Must have a yellow reflective surface area of at least 30 square inches

Arrow Boards may be located behind channelizing devices in place for a shoulder taper or merging taper, otherwise they shall be delineated with four (4) channelizing devices placed perpendicular to traffic on the upstream side of traffic.

- The Flashing Arrow Board should be used for all lane closures on multi-lane roadways, or slow moving maintenance or construction activities on the travel lanes.
- Flashing Arrow Boards should not be used on two-lane, two-way roadways, detours, diversions or work on shoulders unless the "CAUTION" display (see detail below) is used.
- The Engineer/Inspector shall choose all appropriate signs, barricades and/or other traffic control devices that should be used in conjunction with the Flashing Arrow Board.
- The Flashing Arrow Board should be able to display the following symbols:

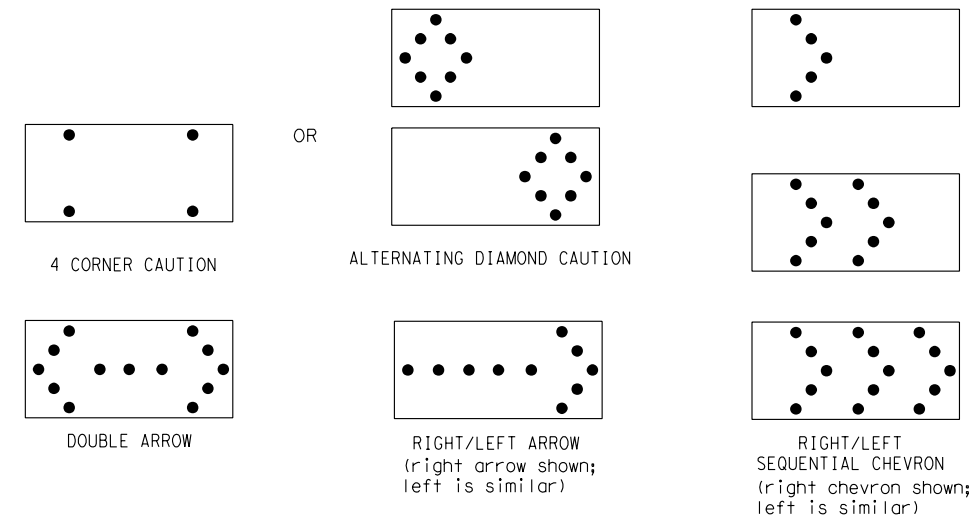

- The "CAUTION" display consists of four corner lamps flashing simultaneously, or the Alternating Diamond Caution mode as shown.
- The straight line caution display is NOT ALLOWED.
- The Flashing Arrow Board shall be capable of minimum 50 percent dimming from rated lamp voltage. The flashing rate of the lamps shall not be less than 25 nor more than 40 flashes per minute.
- Minimum lamp "on time" shall be approximately 50 percent for the flashing arrow and equal intervals of 25 percent for each sequential phase of the flashing chevron.
- The sequential arrow display is NOT ALLOWED.
- The flashing arrow display is the TxDOT standard; however, the sequential chevron display may be used during daylight operations.
- The Flashing Arrow Board shall be mounted on a vehicle, trailer or other suitable support.
- A Flashing Arrow Board SHALL NOT BE USED to laterally shift traffic.
- A full matrix PCMS may be used to simulate a Flashing Arrow Board provided it meets visibility, flash rate and dimming requirements on this sheet for the same size arrow.
- Minimum mounting height of trailer mounted Arrow Boards should be 7 feet from roadway to bottom of panel.

REQUIREMENTS			
TYPE	MINIMUM SIZE	MINIMUM NUMBER OF PANEL LAMPS	MINIMUM VISIBILITY DISTANCE
B	30 x 60	13	3/4 mile
C	48 x 96	15	1 mile

ATTENTION
 Flashing Arrow Boards shall be equipped with automatic dimming devices.

WHEN NOT IN USE, REMOVE THE ARROW BOARD FROM THE RIGHT-OF-WAY OR PLACE THE ARROW BOARD BEHIND CONCRETE TRAFFIC BARRIER OR GUARDRAIL.

FLASHING ARROW BOARDS

SHEET 7 OF 12

TRUCK-MOUNTED ATTENUATORS

- Truck-mounted attenuators (TMA) used on TxDOT facilities must meet the requirements outlined in the Manual for Assessing Safety Hardware (MASH).
- Refer to the CWZTCD for the requirements of Level 2 or Level 3 TMAs.
- Refer to the CWZTCD for a list of approved TMAs.
- TMAs are required on freeways unless otherwise noted in the plans.
- A TMA should be used anytime that it can be positioned 30 to 100 feet in advance of the area of crew exposure without adversely affecting the work performance.
- The only reason a TMA should not be required is when a work area is spread down the roadway and the work crew is an extended distance from the TMA.

Texas Department of Transportation
 Traffic Safety Division Standard

BARRICADE AND CONSTRUCTION ARROW PANEL, REFLECTORS, WARNING LIGHTS & ATTENUATOR

BC (7) - 21

FILE: bc-21.dgn	DN: TxDOT	CK: TxDOT	DW: TxDOT	CK: TxDOT
© TxDOT November 2002	CONT	SECT	JOB	HIGHWAY
REVISIONS				
9-07	8-14			
7-13	5-21	DIST	COUNTY	SHEET NO.
			BEXAR	81

DISCLAIMER: The use of this standard is governed by the "Texas Engineering Practice Act". No warranty of any kind is made by TxDOT for any purpose whatsoever. TxDOT assumes no responsibility for the conversion of this standard to other formats or for incorrect results or damages resulting from its use.

DATE: 1/20/2023 7:07:17 PM
 FILE: K:\COSA\DoI\ososa\STANDARDS\TCP\bc-21.dgn

GENERAL NOTES

- For long term stationary work zones on freeways, drums shall be used as the primary channelizing device.
- For intermediate term stationary work zones on freeways, drums should be used as the primary channelizing device but may be replaced in tangent sections by vertical panels, or 42" two-piece cones. In tangent sections, one-piece cones may be used with the approval of the Engineer but only if personnel are present on the project at all times to maintain the cones in proper position and location.
- For short term stationary work zones on freeways, drums are the preferred channelizing device but may be replaced in tapers, transitions and tangent sections by vertical panels, two-piece cones or one-piece cones as approved by the Engineer.
- Drums and all related items shall comply with the requirements of the current version of the "Texas Manual on Uniform Traffic Control Devices" (TMUTCD) and the "Compliant Work Zone Traffic Control Devices List" (CWZTCD).
- Drums, bases, and related materials shall exhibit good workmanship and shall be free from objectionable marks or defects that would adversely affect their appearance or serviceability.
- The Contractor shall have a maximum of 24 hours to replace any plastic drums identified for replacement by the Engineer/Inspector. The replacement device must be an approved device.

GENERAL DESIGN REQUIREMENTS

Pre-qualified plastic drums shall meet the following requirements:

- Plastic drums shall be a two-piece design; the "body" of the drum shall be the top portion and the "base" shall be the bottom.
- The body and base shall lock together in such a manner that the body separates from the base when impacted by a vehicle traveling at a speed of 20 MPH or greater but prevents accidental separation due to normal handling and/or air turbulence created by passing vehicles.
- Plastic drums shall be constructed of lightweight flexible, and deformable materials. The Contractor shall NOT use metal drums or single piece plastic drums as channelization devices or sign supports.
- Drums shall present a profile that is a minimum of 18 inches in width at the 36 inch height when viewed from any direction. The height of drum unit (body installed on base) shall be a minimum of 36 inches and a maximum of 42 inches.
- The top of the drum shall have a built-in handle for easy pickup and shall be designed to drain water and not collect debris. The handle shall have a minimum of two widely spaced 9/16 inch diameter holes to allow attachment of a warning light, warning reflector unit or approved compliant sign.
- The exterior of the drum body shall have a minimum of four alternating orange and white retroreflective circumferential stripes not less than 4 inches nor greater than 8 inches in width. Any non-reflectorized space between any two adjacent stripes shall not exceed 2 inches in width.
- Bases shall have a maximum width of 36 inches, a maximum height of 4 inches, and a minimum of two footholds of sufficient size to allow base to be held down while separating the drum body from the base.
- Plastic drums shall be constructed of ultra-violet stabilized, orange, high-density polyethylene (HDPE) or other approved material.
- Drum body shall have a maximum unballasted weight of 11 lbs.
- Drum and base shall be marked with manufacturer's name and model number.

RETROREFLECTIVE SHEETING

- The stripes used on drums shall be constructed of sheeting meeting the color and retroreflectivity requirements of Departmental Materials Specification DMS-8300, "Sign Face Materials." Type A or Type B reflective sheeting shall be supplied unless otherwise specified in the plans.
- The sheeting shall be suitable for use on and shall adhere to the drum surface such that, upon vehicular impact, the sheeting shall remain adhered in-place and exhibit no delaminating, cracking, or loss of retroreflectivity other than that loss due to abrasion of the sheeting surface.

BALLAST

- Unballasted bases shall be large enough to hold up to 50 lbs. of sand. This base, when filled with the ballast material, should weigh between 35 lbs (minimum) and 50 lbs (maximum). The ballast may be sand in one to three sandbags separate from the base, sand in a sand-filled plastic base, or other ballasting devices as approved by the Engineer. Stacking of sandbags will be allowed, however height of sandbags above pavement surface may not exceed 12 inches.
- Bases with built-in ballast shall weigh between 40 lbs. and 50 lbs. Built-in ballast can be constructed of an integral crumb rubber base or a solid rubber base.
- Recycled truck tire sidewalls may be used for ballast on drums approved for this type of ballast on the CWZTCD list.
- The ballast shall not be heavy objects, water, or any material that would become hazardous to motorists, pedestrians, or workers when the drum is struck by a vehicle.
- When used in regions susceptible to freezing, drums shall have drainage holes in the bottoms so that water will not collect and freeze becoming a hazard when struck by a vehicle.
- Ballast shall not be placed on top of drums.
- Adhesives may be used to secure base of drums to pavement.

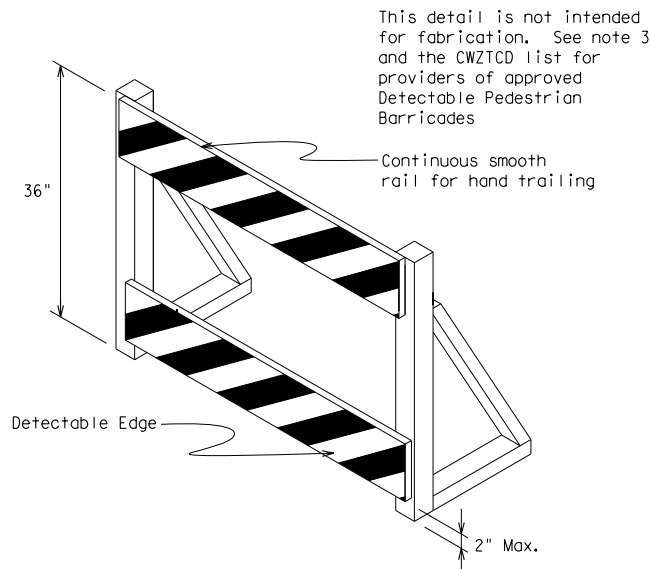
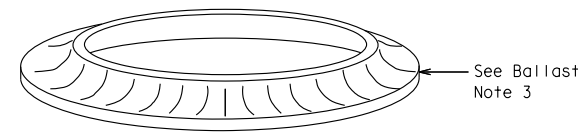
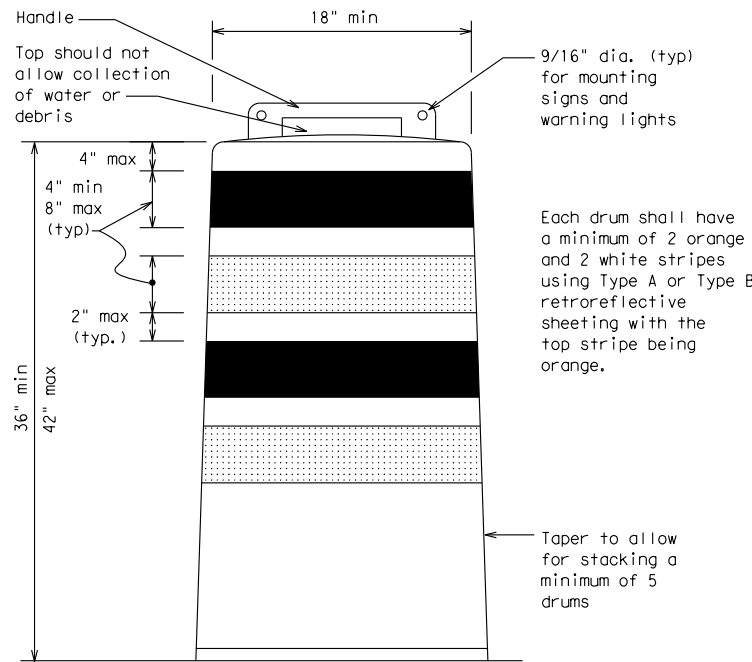

DETECTABLE PEDESTRIAN BARRICADES

- When existing pedestrian facilities are disrupted, closed, or relocated in a TTC zone, the temporary facilities shall be detectable and include accessibility features consistent with the features present in the existing pedestrian facility. Refer to WZ(BTS-2) for Pedestrian Control requirements for Sidewalk Diversions, Sidewalk Detours and Crosswalk Closures.
- Where pedestrians with visual disabilities normally use the closed sidewalk, a Detectable Pedestrian Barricade shall be placed across the full width of the closed sidewalk instead of a Type 3 Barricade.
- Detectable pedestrian barricades similar to the one pictured above, longitudinal channelizing devices, some concrete barriers, and wood or chain link fencing with a continuous detectable edging can satisfactorily delineate a pedestrian path.
- Tape, rope, or plastic chain strung between devices are not detectable, do not comply with the design standards in the "Americans with Disabilities Act Accessibility Guidelines (ADAAG)" and should not be used as a control for pedestrian movements.
- Warning lights shall not be attached to detectable pedestrian barricades.
- Detectable pedestrian barricades should use 8" nominal barricade rails as shown on BC(10) provided that the top rail provides a smooth continuous rail suitable for hand trailing with no splinters, burrs, or sharp edges.

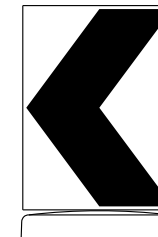

18" x 24" Sign
(Maximum Sign Dimension)
Chevron CW1-8, Opposing Traffic Lane Divider, Driveway sign D70a, Keep Right R4 series or other signs as approved by Engineer

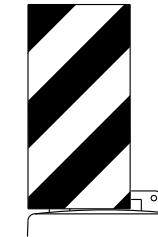

12" x 24" Vertical Panel
mount with diagonals sloping down towards travel way

Plywood, Aluminum or Metal sign substrates shall NOT be used on plastic drums

SIGNS, CHEVRONS, AND VERTICAL PANELS MOUNTED ON PLASTIC DRUMS

- Signs used on plastic drums shall be manufactured using substrates listed on the CWZTCD.
- Chevrons and other work zone signs with an orange background shall be manufactured with Type B_{FL} or Type C_{FL} Orange sheeting meeting the color and retroreflectivity requirements of DMS-8300, "Sign Face Material," unless otherwise specified in the plans.
- Vertical Panels shall be manufactured with orange and white sheeting meeting the requirements of DMS-8300 Type A or Type B. Diagonal stripes on Vertical Panels shall slope down toward the intended traveled lane.
- Other sign messages (text or symbolic) may be used as approved by the Engineer. Sign dimensions shall not exceed 18 inches in width or 24 inches in height, except for the R9 series signs discussed in note 8 below.
- Signs shall be installed using a 1/2 inch bolt (nominal) and nut, two washers, and one locking washer for each connection.
- Mounting bolts and nuts shall be fully engaged and adequately torqued. Bolts should not extend more than 1/2 inch beyond nuts.
- Chevrons may be placed on drums on the outside of curves, on merging tapers or on shifting tapers. When used in these locations, they may be placed on every drum or spaced not more than on every third drum. A minimum of three (3) should be used at each location called for in the plans.
- R9-9, R9-10, R9-11 and R9-11a Sidewalk Closed signs which are 24 inches wide may be mounted on plastic drums, with approval of the Engineer.

SHEET 8 OF 12



BARRICADE AND CONSTRUCTION CHANNELIZING DEVICES

BC (8) - 21

FILE:	bc-21.dgn	DN:	TxDOT	CK:	TxDOT	DW:	TxDOT	CK:	TxDOT
© TxDOT	November 2002	CONT	SECT	JOB	HIGHWAY				
REVISIONS				COUNTY		SHEET NO.			
4-03	8-14			BEXAR		82			
9-07	5-21								
7-13									

DISCLAIMER: The use of this standard is governed by the "Texas Engineering Practice Act". No warranty of any kind is made by TxDOT for any purpose whatsoever. TxDOT assumes no responsibility for the conversion of this standard to other formats or for incorrect results or damages resulting from its use.

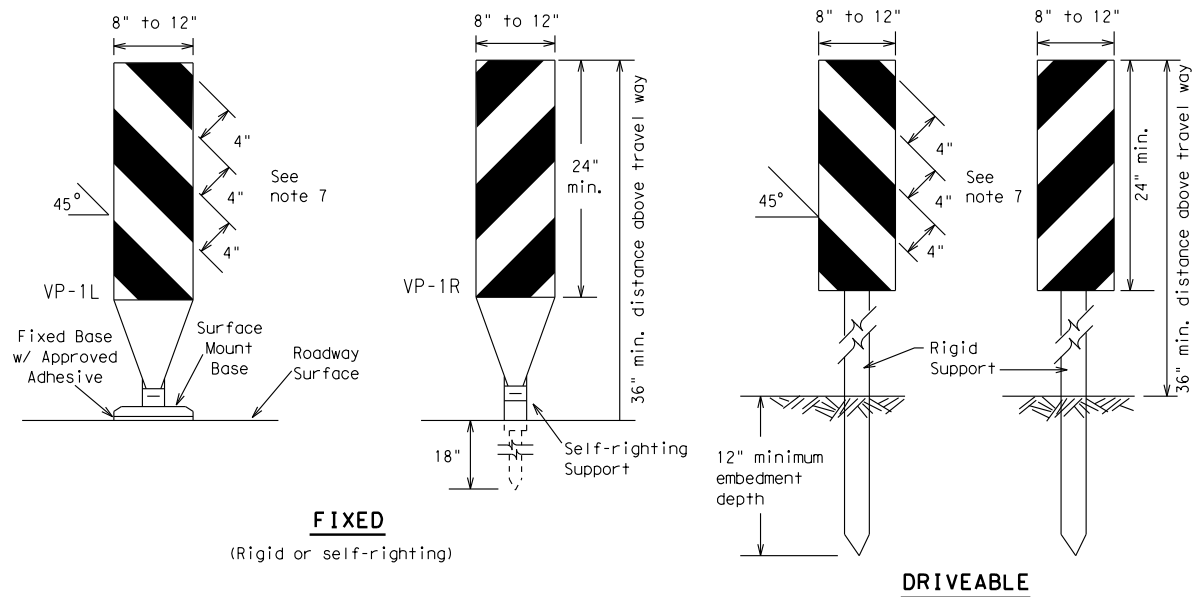

FIXED
(Rigid or self-righting)

DRIVEABLE

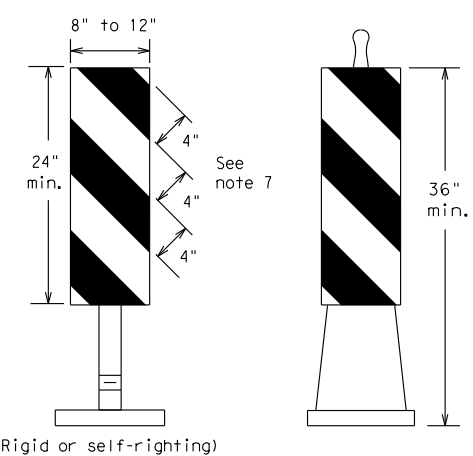

PORTABLE

VERTICAL PANELS (VPs)

- Vertical Panels (VP's) are normally used to channelize traffic or divide opposing lanes of traffic.
- VP's may be used in daytime or nighttime situations. They may be used at the edge of shoulder drop-offs and other areas such as lane transitions where positive daytime and nighttime delineation is required. The Engineer/Inspector shall refer to the Roadway Design Manual for additional requirements on the use VP's for drop-offs.
- VP's should be mounted back to back if used at the edge of cuts adjacent to two-way two lane roadways. Stripes are to be reflective orange and reflective white and should always slope downward toward the travel lane.
- VP's used on expressways and freeways or other high speed roadways, may have more than 270 square inches of retroreflective area facing traffic.
- Self-righting supports are available with portable base. See "Compliant Work Zone Traffic Control Devices List" (CWZTCD).
- Sheeting for the VP's shall be retroreflective Type A or Type B conforming to Departmental Material Specification DMS-8300, unless noted otherwise.
- Where the height of reflective material on the vertical panel is 36 inches or greater, a panel stripe of 6 inches shall be used.

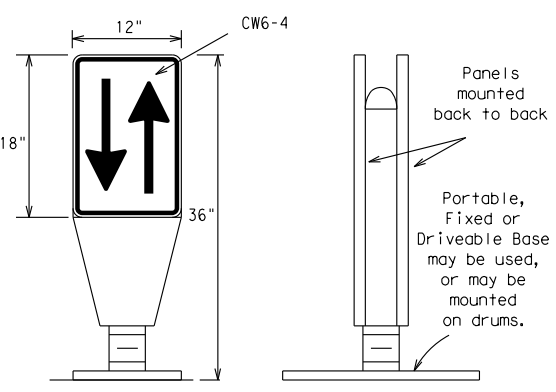

OPPOSING TRAFFIC LANE DIVIDERS (OTLD)

- Opposing Traffic Lane Dividers (OTLD) are delineation devices designed to convert a normal one-way roadway section to two-way operation. OTLD's are used on temporary centerlines. The upward and downward arrows on the sign's face indicate the direction of traffic on either side of the divider. The base is secured to the pavement with an adhesive or rubber weight to minimize movement caused by a vehicle impact or wind gust.
- The OTLD may be used in combination with 42" cones or VPs.
- Spacing between the OTLD shall not exceed 500 feet. 42" cones or VPs placed between the OTLD's should not exceed 100 foot spacing.
- The OTLD shall be orange with a black non-reflective legend. Sheeting for the OTLD shall be retroreflective Type B_{FL} or Type C_{FL} conforming to Departmental Material Specification DMS-8300, unless noted otherwise. The legend shall meet the requirements of DMS-8300.

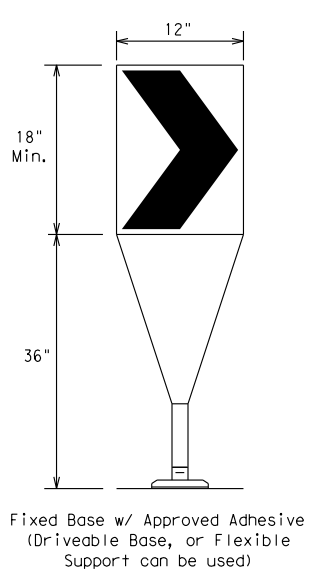

CHEVRONS

- The chevron shall be a vertical rectangle with a minimum size of 12 by 18 inches.
- Chevrons are intended to give notice of a sharp change of alignment with the direction of travel and provide additional emphasis and guidance for vehicle operators with regard to changes in horizontal alignment of the roadway.
- Chevrons, when used, shall be erected on the outside of a sharp curve or turn, or on the far side of an intersection. They shall be in line with and at right angles to approaching traffic. Spacing should be such that the motorist always has three in view, until the change in alignment eliminates its need.
- To be effective, the chevron should be visible for at least 500 feet.
- Chevrons shall be orange with a black nonreflective legend. Sheeting for the chevron shall be retroreflective Type B_{FL} or Type C_{FL} conforming to Departmental Material Specification DMS-8300, unless noted otherwise. The legend shall meet the requirements of DMS-8300.
- For Long Term Stationary use on tapers or transitions on freeways and divided highways, self-righting chevrons may be used to supplement plastic drums but not to replace plastic drums.

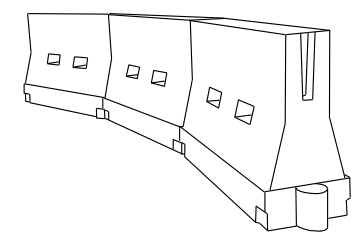

LONGITUDINAL CHANNELIZING DEVICES (LCD)

- LCDs are crashworthy, lightweight, deformable devices that are highly visible, have good target value and can be connected together. They are not designed to contain or redirect a vehicle on impact.
- LCDs may be used instead of a line of cones or drums.
- LCDs shall be placed in accordance to application and installation requirements specific to the device, and used only when shown on the CWZTCD list.
- LCDs should not be used to provide positive protection for obstacles, pedestrians or workers.
- LCDs shall be supplemented with retroreflective delineation as required for temporary barriers on BC(7) when placed roughly parallel to the travel lanes.
- LCDs used as barricades placed perpendicular to traffic should have at least one row of reflective sheeting meeting the requirements for barricade rails as shown on BC(10). Place reflective sheeting near the top of the LCD along the full length of the device.

WATER BALLASTED SYSTEMS USED AS BARRIERS

- Water ballasted systems used as barriers shall not be used solely to channelize road users, but also to protect the work space per the appropriate Manual for Assessing Safety Hardware (MASH) crashworthiness requirements based on roadway speed and barrier application.
- Water ballasted systems used to channelize vehicular traffic shall be supplemented with retroreflective delineation or channelizing devices to improve daytime/nighttime visibility. They may also be supplemented with pavement markings.
- Water ballasted systems used as barriers shall be placed in accordance to application and installation requirements specific to the device, and used only when shown on the CWZTCD list.
- Water ballasted systems used as barriers should not be used for a merging taper except in low speed (less than 45 MPH) urban areas. When used on a taper in a low speed urban area, the taper shall be delineated and the taper length should be designed to optimize road user operations considering the available geometric conditions.
- When water ballasted systems used as barriers have blunt ends exposed to traffic, they should be attenuated as per manufacturer recommendations or flared to a point outside the clear zone.

If used to channelize pedestrians, longitudinal channelizing devices or water ballasted systems must have a continuous detectable bottom for users of long canes and the top of the unit shall not be less than 32 inches in height.

HOLLOW OR WATER BALLASTED SYSTEMS USED AS LONGITUDINAL CHANNELIZING DEVICES OR BARRIERS

GENERAL NOTES

- Work Zone channelizing devices illustrated on this sheet may be installed in close proximity to traffic and are suitable for use on high or low speed roadways. The Engineer/Inspector shall ensure that spacing and placement is uniform and in accordance with the "Texas Manual on Uniform Traffic Control Devices" (TMUTCD).
- Channelizing devices shown on this sheet may have a driveable, fixed or portable base. The requirement for self-righting channelizing devices must be specified in the General Notes or other plan sheets.
- Channelizing devices on self-righting supports should be used in work zone areas where channelizing devices are frequently impacted by errant vehicles or vehicle related wind gusts making alignment of the channelizing devices difficult to maintain. Locations of these devices shall be detailed elsewhere in the plans. These devices shall conform to the TMUTCD and the "Compliant Work Zone Traffic Control Devices List" (CWZTCD).
- The Contractor shall maintain devices in a clean condition and replace damaged, nonreflective, faded, or broken devices and bases as required by the Engineer/Inspector. The Contractor shall be required to maintain proper device spacing and alignment.
- Portable bases shall be fabricated from virgin and/or recycled rubber. The portable bases shall weigh a minimum of 30 lbs.
- Pavement surfaces shall be prepared in a manner that ensures proper bonding between the adhesives, the fixed mount bases and the pavement surface. Adhesives shall be prepared and applied according to the manufacturer's recommendations.
- The installation and removal of channelizing devices shall not cause detrimental effects to the final pavement surfaces, including pavement surface discoloration or surface integrity. Driveable bases shall not be permitted on final pavement surfaces. The Engineer/Inspector shall approve all application and removal procedures of fixed bases.

Posted Speed	Formula	Minimum Desirable Taper Lengths * X			Suggested Maximum Spacing of Channelizing Devices	
		10' Offset	11' Offset	12' Offset	On a Taper	On a Tangent
30	$L = \frac{WS^2}{60}$	150'	165'	180'	30'	60'
35		205'	225'	245'	35'	70'
40		265'	295'	320'	40'	80'
45	L = WS	450'	495'	540'	45'	90'
50		500'	550'	600'	50'	100'
55		550'	605'	660'	55'	110'
60		600'	660'	720'	60'	120'
65		650'	715'	780'	65'	130'
70		700'	770'	840'	70'	140'
75		750'	825'	900'	75'	150'
80		800'	880'	960'	80'	160'

*X Taper lengths have been rounded off.
L=Length of Taper (FT.) W=Width of Offset (FT.)
S=Posted Speed (MPH)

SUGGESTED MAXIMUM SPACING OF CHANNELIZING DEVICES AND MINIMUM DESIRABLE TAPER LENGTHS

SHEET 9 OF 12



BARRICADE AND CONSTRUCTION CHANNELIZING DEVICES

BC (9) - 21

FILE: bc-21.dgn	DN: TxDOT	CK: TxDOT	DW: TxDOT	CK: TxDOT
© TxDOT November 2002	CONT	SECT	JOB	HIGHWAY
REVISIONS				
9-07 8-14				COSA
7-13 5-21	DIST	COUNTY	SHEET NO.	
		BEXAR	83	

DATE: 1/20/2023 7:07:18 PM
FILE: K:\COSA\DoI\os\STANDARDS\TCP\bc-21.dgn

DISCLAIMER: The use of this standard is governed by the "Texas Engineering Practice Act". No warranty of any kind is made by TxDOT for any purpose whatsoever. TxDOT assumes no responsibility for the conversion of this standard to other formats or for incorrect results or damages resulting from its use.

TYPE 3 BARRICADES

1. Refer to the Compliant Work Zone Traffic Control Devices List (CWZTCD) for details of the Type 3 Barricades and a list of all materials used in the construction of Type 3 Barricades.
2. Type 3 Barricades shall be used at each end of construction projects closed to all traffic.
3. Barricades extending across a roadway should have stripes that slope downward in the direction toward which traffic must turn in detouring. When both right and left turns are provided, the chevron striping may slope downward in both directions from the center of the barricade. Where no turns are provided at a closed road, striping should slope downward in both directions toward the center of roadway.
4. Striping of rails, for the right side of the roadway, should slope downward to the left. For the left side of the roadway, striping should slope downward to the right.
5. Identification markings may be shown only on the back of the barricade rails. The maximum height of letters and/or company logos used for identification shall be 1".
6. Barricades shall not be placed parallel to traffic unless an adequate clear zone is provided.
7. Warning lights shall NOT be installed on barricades.
8. Where barricades require the use of weights to keep from turning over, the use of sandbags with dry, cohesionless sand is recommended. The sandbags will be tied shut to keep the sand from spilling and to maintain a constant weight. Sand bags shall not be stacked in a manner that covers any portion of a barricade rails reflective sheeting. Rock, concrete, iron, steel or other solid objects will NOT be permitted. Sandbags should weigh a minimum of 35 lbs and a maximum of 50 lbs. Sandbags shall be made of a durable material that tears upon vehicular impact. Rubber (such as tire inner tubes) shall not be used for sandbags. Sandbags shall only be placed along or upon the base supports of the device and shall not be suspended above ground level or hung with rope, wire, chains or other fasteners.
9. Sheeting for barricades shall be retroreflective Type A or Type B conforming to Departmental Material Specification DMS-8300 unless otherwise noted.

Barricades shall NOT be used as a sign support.

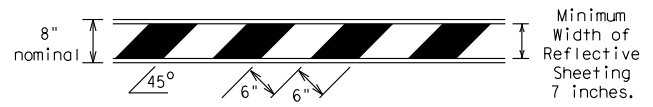

TYPICAL STRIPING DETAIL FOR BARRICADE RAIL

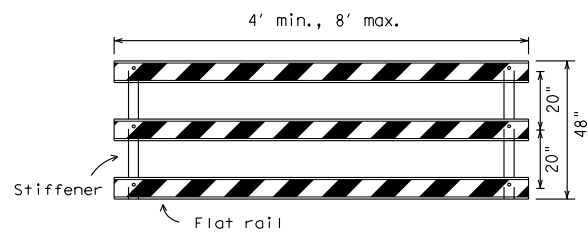

Stiffener may be inside or outside of support, but no more than 2 stiffeners shall be allowed on one barricade.

TYPICAL PANEL DETAIL FOR SKID OR POST TYPE BARRICADES

Each roadway of a divided highway shall be barricaded in the same manner.

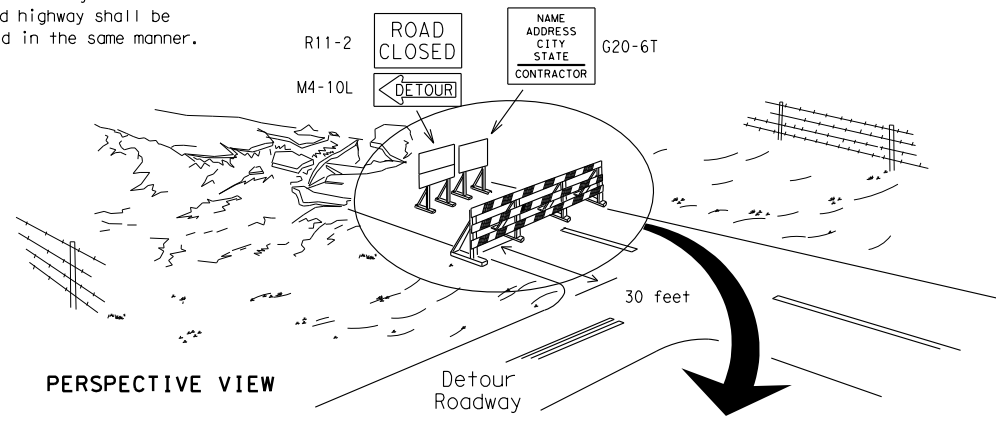

PERSPECTIVE VIEW

The three rails on Type 3 barricades shall be reflectorized orange and reflective white stripes on one side facing one-way traffic and both sides for two-way traffic. Barricade striping should slant downward in the direction of detour.

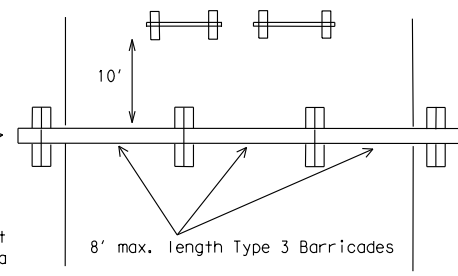

PLAN VIEW

1. Signs should be mounted on independent supports at a 7 foot mounting height in center of roadway. The signs should be a minimum of 10 feet behind Type 3 Barricades.
2. Advance signing shall be as specified elsewhere in the plans.

TYPE 3 BARRICADE (POST AND SKID) TYPICAL APPLICATION

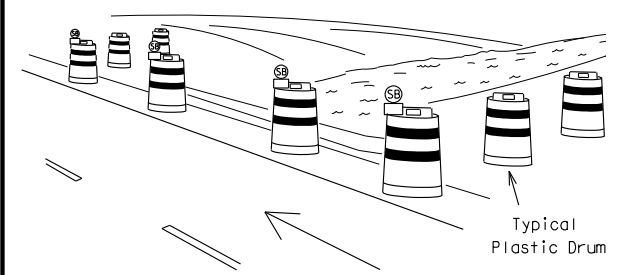

PERSPECTIVE VIEW

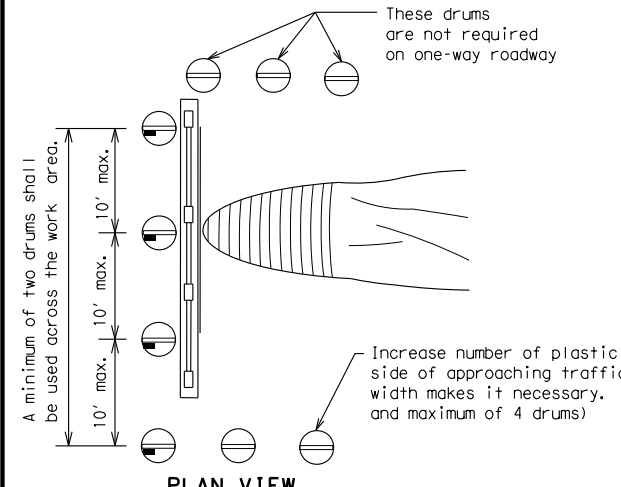

PLAN VIEW

CULVERT WIDENING OR OTHER ISOLATED WORK WITHIN THE PROJECT LIMITS

1. Where positive redirection capability is provided, drums may be omitted.
2. Plastic construction fencing may be used with drums for safety as required in the plans.
3. Vertical Panels on flexible support may be substituted for drums when the shoulder width is less than 4 feet.
4. When the shoulder width is greater than 12 feet, steady-burn lights may be omitted if drums are used.
5. Drums must extend the length of the culvert widening.

LEGEND	
	Plastic drum
	Plastic drum with steady burn light or yellow warning reflector
	Steady burn warning light or yellow warning reflector

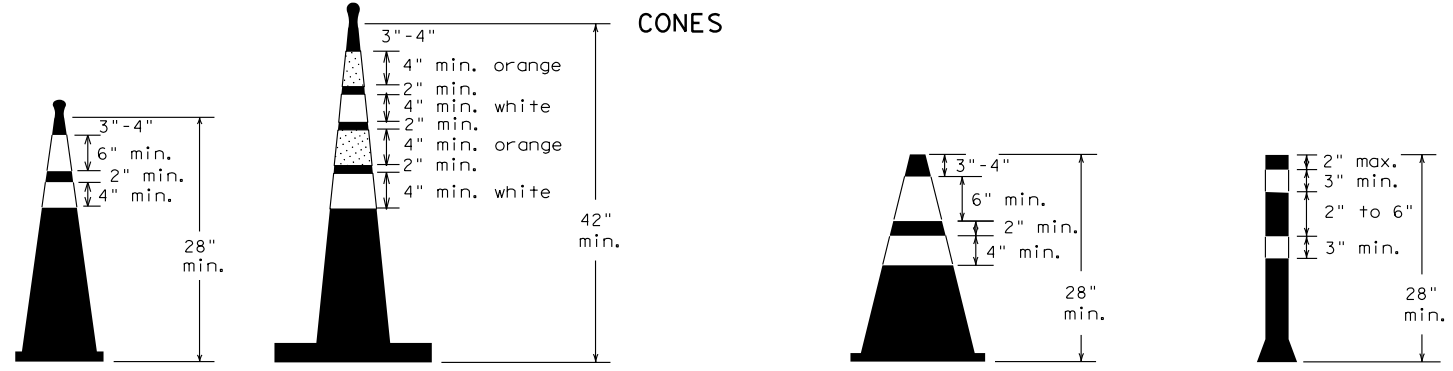

Two-Piece cones

One-Piece cones

Tubular Marker

28" Cones shall have a minimum weight of 9 1/2 lbs.
 42" 2-piece cones shall have a minimum weight of 30 lbs. including base.

1. Traffic cones and tubular markers shall be predominantly orange, and meet the height and weight requirements shown above.
2. One-piece cones have the body and base of the cone molded in one consolidated unit. Two-piece cones have a cone shaped body and a separate rubber base, or ballast, that is added to keep the device upright and in place.
3. Two-piece cones may have a handle or loop extending up to 8" above the minimum height shown, in order to aid in retrieving the device.
4. Cones or tubular markers shall have white or white and orange reflective bands as shown above. The reflective bands shall have a smooth, sealed outer surface and meet the requirements of Departmental Material Specification DMS-8300 Type A or Type B.
5. 28" cones and tubular markers are generally suitable for short duration and short-term stationary work as defined on BC(4). These should not be used for intermediate-term or long-term stationary work unless personnel is on-site to maintain them in their proper upright position.
6. 42" two-piece cones, vertical panels or drums are suitable for all work zone durations.
7. Cones or tubular markers used on each project should be of the same size and shape.

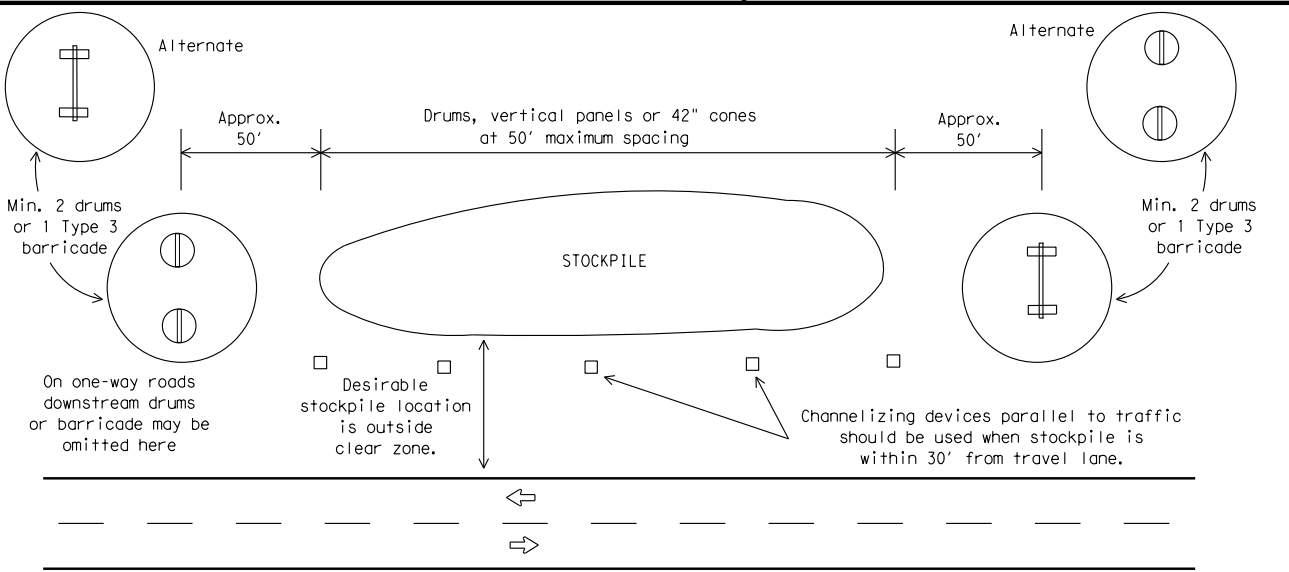

TRAFFIC CONTROL FOR MATERIAL STOCKPILES



BARRICADE AND CONSTRUCTION CHANNELIZING DEVICES

BC (10) - 21

FILE: bc-21.dgn	DN: TxDOT	CK: TxDOT	DW: TxDOT	CK: TxDOT
© TxDOT November 2002	CONT	SECT	JOB	HIGHWAY
REVISIONS				
9-07 8-14				COSA
7-13 5-21	DIST	COUNTY	SHEET NO.	
		BEXAR	84	

DATE: 1/20/2023 7:07:19 PM
 FILE: K:\COSA\DoI\osa\STANDARDS\TCP\bc-21.dgn

WORK ZONE PAVEMENT MARKINGS

GENERAL

- The Contractor shall be responsible for maintaining work zone and existing pavement markings, in accordance with the standard specifications and special provisions, on all roadways open to traffic within the CSJ limits unless otherwise stated in the plans.
- Color, patterns and dimensions shall be in conformance with the "Texas Manual on Uniform Traffic Control Devices" (TMUTCD).
- Additional supplemental pavement marking details may be found in the plans or specifications.
- Pavement markings shall be installed in accordance with the TMUTCD and as shown on the plans.
- When short term markings are required on the plans, short term markings shall conform with the TMUTCD, the plans and details as shown on the Standard Plan Sheet WZ(STPM).
- When standard pavement markings are not in place and the roadway is opened to traffic, DO NOT PASS signs shall be erected to mark the beginning of the sections where passing is prohibited and PASS WITH CARE signs at the beginning of sections where passing is permitted.
- All work zone pavement markings shall be installed in accordance with Item 662, "Work Zone Pavement Markings."

RAISED PAVEMENT MARKERS

- Raised pavement markers are to be placed according to the patterns on BC(12).
- All raised pavement markers used for work zone markings shall meet the requirements of Item 672, "RAISED PAVEMENT MARKERS" and Departmental Material Specification DMS-4200 or DMS-4300.

PREFABRICATED PAVEMENT MARKINGS

- Removable prefabricated pavement markings shall meet the requirements of DMS-8241.
- Non-removable prefabricated pavement markings (foil back) shall meet the requirements of DMS-8240.

MAINTAINING WORK ZONE PAVEMENT MARKINGS

- The Contractor will be responsible for maintaining work zone pavement markings within the work limits.
- Work zone pavement markings shall be inspected in accordance with the frequency and reporting requirements of work zone traffic control device inspections as required by Form 599.
- The markings should provide a visible reference for a minimum distance of 300 feet during normal daylight hours and 160 feet when illuminated by automobile low-beam headlights at night, unless sight distance is restricted by roadway geometrics.
- Markings failing to meet this criteria within the first 30 days after placement shall be replaced at the expense of the Contractor as per Specification Item 662.

REMOVAL OF PAVEMENT MARKINGS

- Pavement markings that are no longer applicable, could create confusion or direct a motorist toward or into the closed portion of the roadway shall be removed or obliterated before the roadway is opened to traffic.
- The above shall not apply to detours in place for less than three days, where flaggers and/or sufficient channelizing devices are used in lieu of markings to outline the detour route.
- Pavement markings shall be removed to the fullest extent possible, so as not to leave a discernable marking. This shall be by any method approved by TxDOT Specification Item 677 for "Eliminating Existing Pavement Markings and Markers".
- The removal of pavement markings may require resurfacing or seal coating portions of the roadway as described in Item 677.
- Subject to the approval of the Engineer, any method that proves to be successful on a particular type pavement may be used.
- Blast cleaning may be used but will not be required unless specifically shown in the plans.
- Over-painting of the markings SHALL NOT BE permitted.
- Removal of raised pavement markers shall be as directed by the Engineer.
- Removal of existing pavement markings and markers will be paid for directly in accordance with Item 677, "ELIMINATING EXISTING PAVEMENT MARKINGS AND MARKERS," unless otherwise stated in the plans.
- Black-out marking tape may be used to cover conflicting existing markings for periods less than two weeks when approved by the Engineer.

Temporary Flexible-Reflective Roadway Marker Tabs

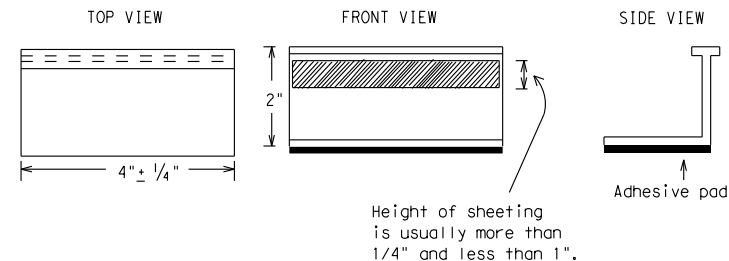

**STAPLES OR NAILS SHALL NOT BE USED TO SECURE
TEMPORARY FLEXIBLE-REFLECTIVE ROADWAY MARKER
TABS TO THE PAVEMENT SURFACE**

- Temporary flexible-reflective roadway marker tabs used as guidemarks shall meet the requirements of DMS-8242.
- Tabs detailed on this sheet are to be inspected and accepted by the Engineer or designated representative. Sampling and testing is not normally required, however at the option of the Engineer, either "A" or "B" below may be imposed to assure quality before placement on the roadway.
 - Select five (5) or more tabs at random from each lot or shipment and submit to the Construction Division, Materials and Pavement Section to determine specification compliance.
 - Select five (5) tabs and perform the following test. Affix five (5) tabs at 24 inch intervals on an asphaltic pavement in a straight line. Using a medium size passenger vehicle or pickup, run over the markers with the front and rear tires at a speed of 35 to 40 miles per hour, four (4) times in each direction. No more than one (1) out of the five (5) reflective surfaces shall be lost or displaced as a result of this test.
- Small design variances may be noted between tab manufacturers.
- See Standard Sheet WZ(STPM) for tab placement on new pavements. See Standard Sheet TCP(7-1) for tab placement on seal coat work.

RAISED PAVEMENT MARKERS USED AS GUIDEMARKS

- Raised pavement markers used as guidemarks shall be from the approved product list, and meet the requirements of DMS-4200.
- All temporary construction raised pavement markers provided on a project shall be of the same manufacturer.
- Adhesive for guidemarks shall be bituminous material hot applied or butyl rubber pad for all surfaces, or thermoplastic for concrete surfaces.

Guidemarks shall be designated as:
 YELLOW - (two amber reflective surfaces with yellow body).
 WHITE - (one silver reflective surface with white body).

DEPARTMENTAL MATERIAL SPECIFICATIONS	
PAVEMENT MARKERS (REFLECTORIZED)	DMS-4200
TRAFFIC BUTTONS	DMS-4300
EPOXY AND ADHESIVES	DMS-6100
BITUMINOUS ADHESIVE FOR PAVEMENT MARKERS	DMS-6130
PERMANENT PREFABRICATED PAVEMENT MARKINGS	DMS-8240
TEMPORARY REMOVABLE, PREFABRICATED PAVEMENT MARKINGS	DMS-8241
TEMPORARY FLEXIBLE, REFLECTIVE ROADWAY MARKER TABS	DMS-8242

A list of prequalified reflective raised pavement markers, non-reflective traffic buttons, roadway marker tabs and other pavement markings can be found at the Material Producer List web address shown on BC(1).

SHEET 11 OF 12



BARRICADE AND CONSTRUCTION PAVEMENT MARKINGS

BC(11)-21

FILE: bc-21.dgn	DN: TxDOT	CK: TxDOT	DW: TxDOT	CK: TxDOT
© TxDOT February 1998	CONT	SECT	JOB	HIGHWAY
REVISIONS				
2-98	9-07	5-21		COSA
1-02	7-13			
11-02	8-14			
	DIST	COUNTY	SHEET NO.	
		BEXAR	85	

DISCLAIMER: The use of this standard is governed by the "Texas Engineering Practice Act". No warranty of any kind is made by TxDOT for any purpose whatsoever. TxDOT assumes no responsibility for the conversion of this standard to other formats or for incorrect results or damages resulting from its use.

DATE: 1/20/2023 7:07:19 PM
FILE: K:\COSA_Doloresa\STANDARDS\TCP\bc-21.dgn

PAVEMENT MARKING PATTERNS

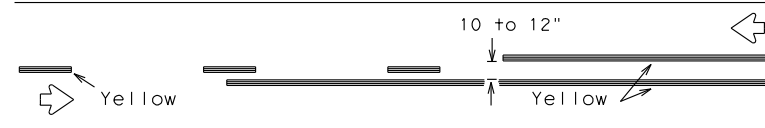

REFLECTORIZED PAVEMENT MARKINGS - PATTERN A

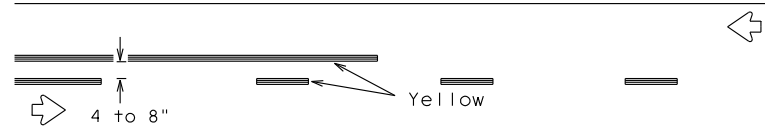

REFLECTORIZED PAVEMENT MARKINGS - PATTERN B

Pattern A is the TxDOT Standard, however Pattern B may be used if approved by the Engineer. Prefabricated markings may be substituted for reflectorized pavement markings.

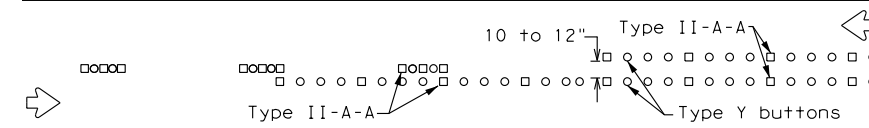

RAISED PAVEMENT MARKERS - PATTERN A

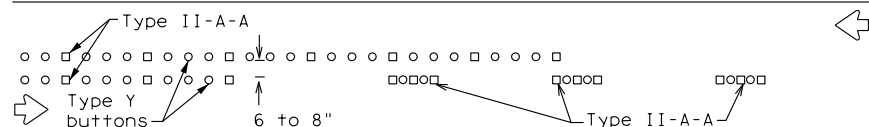

RAISED PAVEMENT MARKERS - PATTERN B

CENTER LINE & NO-PASSING ZONE BARRIER LINES FOR TWO-LANE, TWO-WAY HIGHWAYS

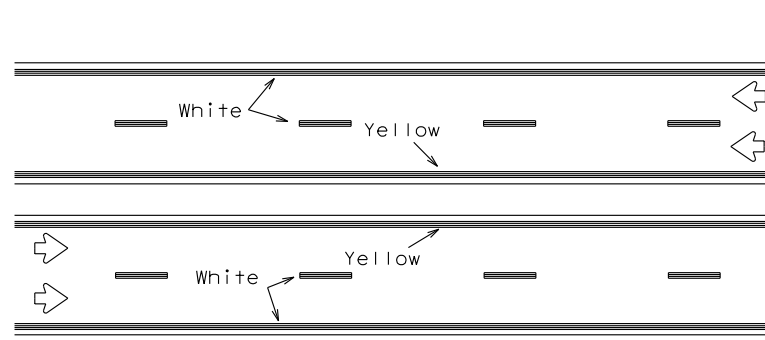

REFLECTORIZED PAVEMENT MARKINGS

Prefabricated markings may be substituted for reflectorized pavement markings.

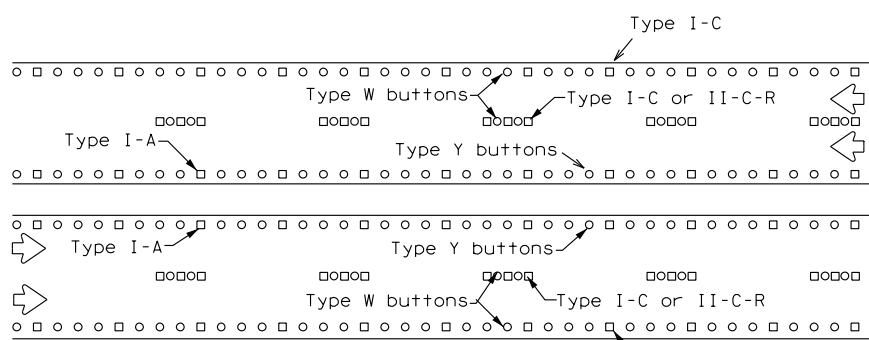

RAISED PAVEMENT MARKERS

EDGE & LANE LINES FOR DIVIDED HIGHWAY

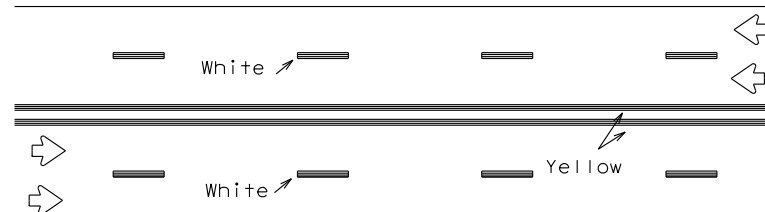

REFLECTORIZED PAVEMENT MARKINGS

Prefabricated markings may be substituted for reflectorized pavement markings.

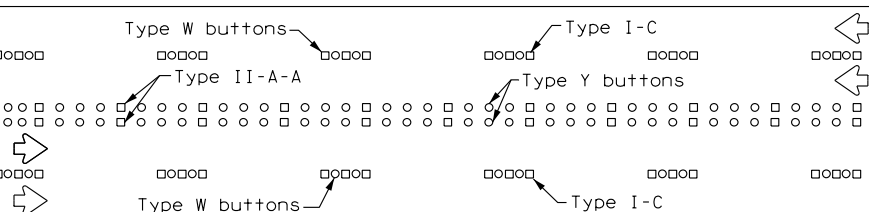

RAISED PAVEMENT MARKERS

LANE & CENTER LINES FOR MULTILANE UNDIVIDED HIGHWAYS

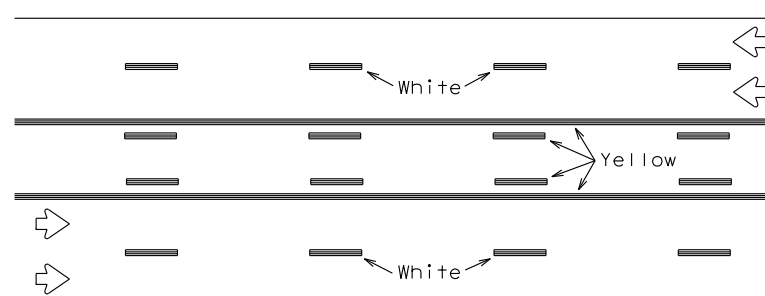

REFLECTORIZED PAVEMENT MARKINGS

Prefabricated markings may be substituted for reflectorized pavement markings.

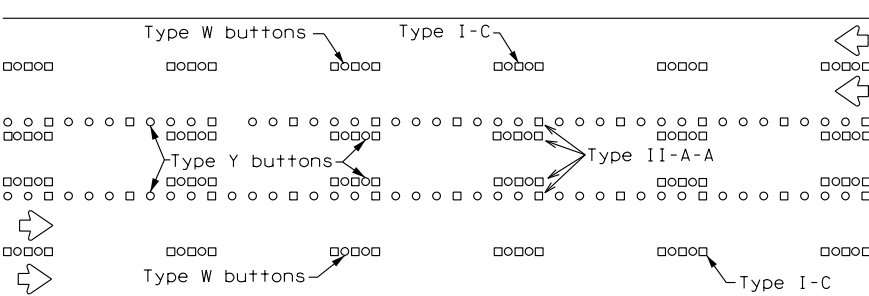

RAISED PAVEMENT MARKERS

TWO-WAY LEFT TURN LANE

STANDARD WORK ZONE PAVEMENT MARKINGS DETAILS

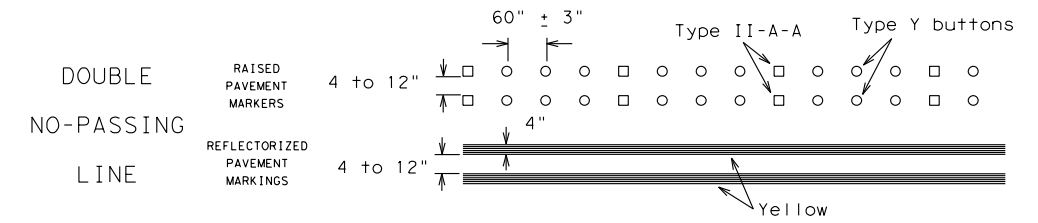

SOLID LINES

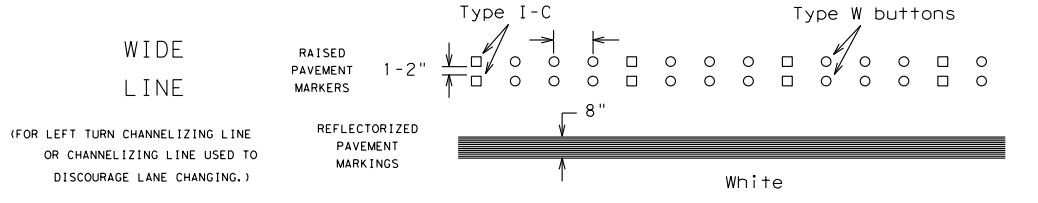
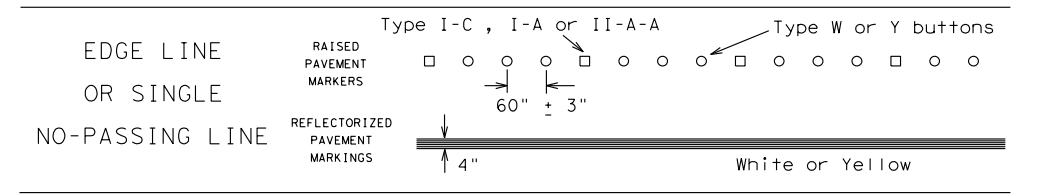

BROKEN LINES

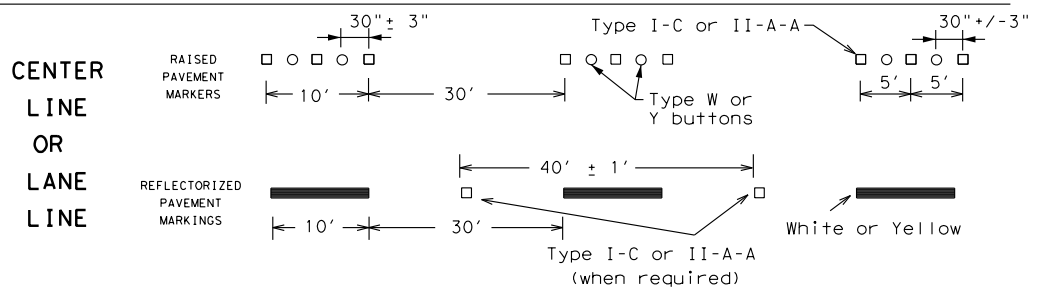

AUXILIARY OR LANEDROP LINE

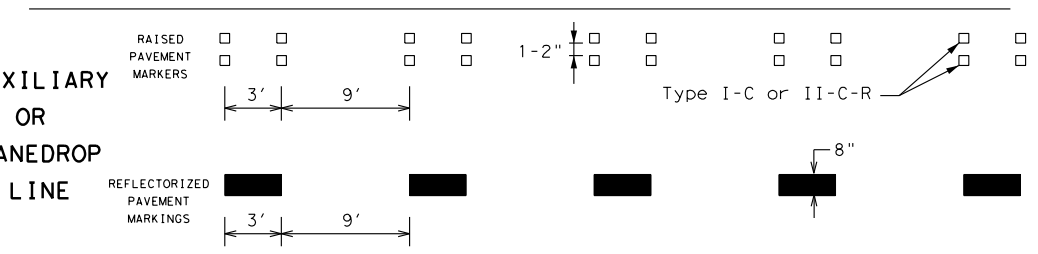

REMOVABLE MARKINGS WITH RAISED PAVEMENT MARKERS

If raised pavement markers are used to supplement REMOVABLE markings, the markers shall be applied to the top of the tape at the approximate mid length of tape used for broken lines or at 20 foot spacing for solid lines. This allows an easier removal of raised pavement markers and tape.

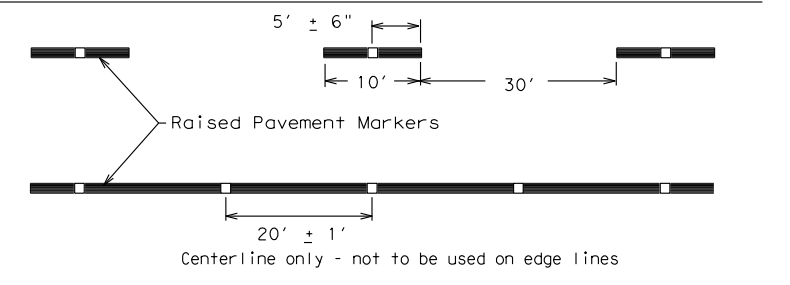

SHEET 12 OF 12



BARRICADE AND CONSTRUCTION PAVEMENT MARKING PATTERNS

BC(12)-21

FILE: bc-21.dgn	DN: TxDOT	CK: TxDOT	OW: TxDOT	CK: TxDOT
©TxDOT February 1998	CONT	SECT	JOB	HIGHWAY
REVISIONS	COSA			
1-97 9-07 5-21				
2-98 7-13				
11-02 8-14				
DIST	COUNTY	SHEET NO.		
	BEXAR	86		

DISCLAIMER: The use of this standard is governed by the "Texas Engineering Practice Act". No warranty of any kind is made by TxDOT for any purpose whatsoever. TxDOT assumes no responsibility for the conversion of this standard to other formats or for incorrect results or damages resulting from its use.

DATE: 1/20/2023 7:07:20 PM
FILE: K:\COSA_Dolores\STANDARDS\TCP\bc-21.dgn

DISCLAIMER: The use of this standard is governed by the "Texas Engineering Practice Act". No warranty of any kind is made by TxDOT for any purpose whatsoever. TxDOT assumes no responsibility for the conversion of this standard to other formats or for incorrect results or damages resulting from its use.

DATE: 1/20/2023 7:07:23 PM
 FILE: K:\COSA\DoI\osca\STANDARDS\TCP\wzbtfs-13.dgn

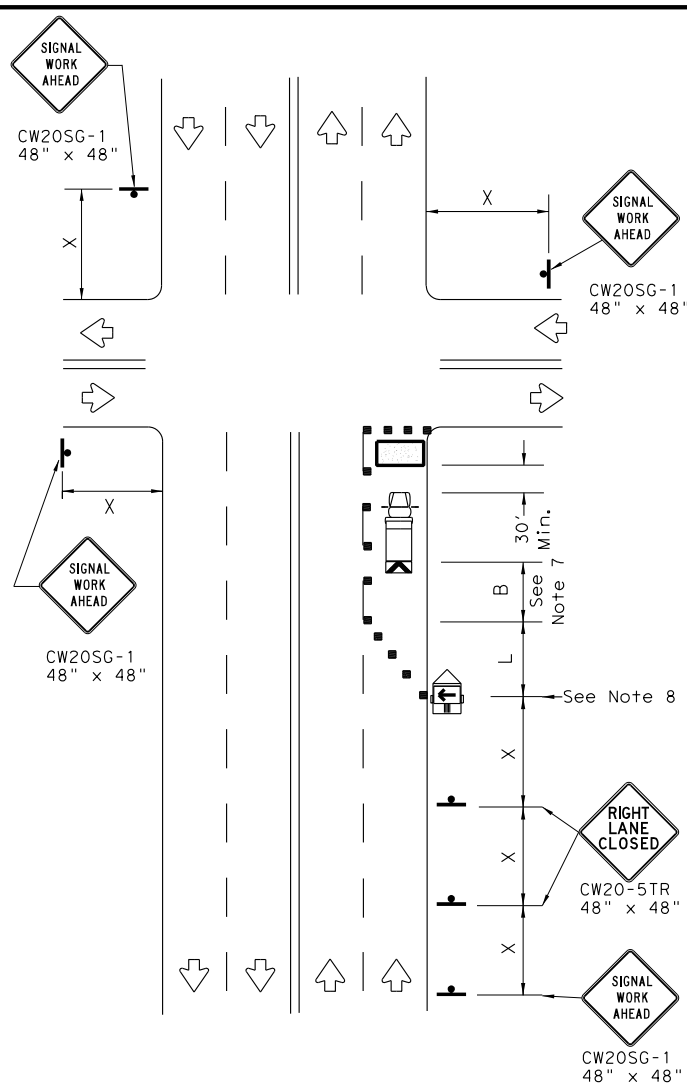

NEAR SIDE LANE CLOSURE
 SHORT DURATION OR SHORT TERM STATIONARY

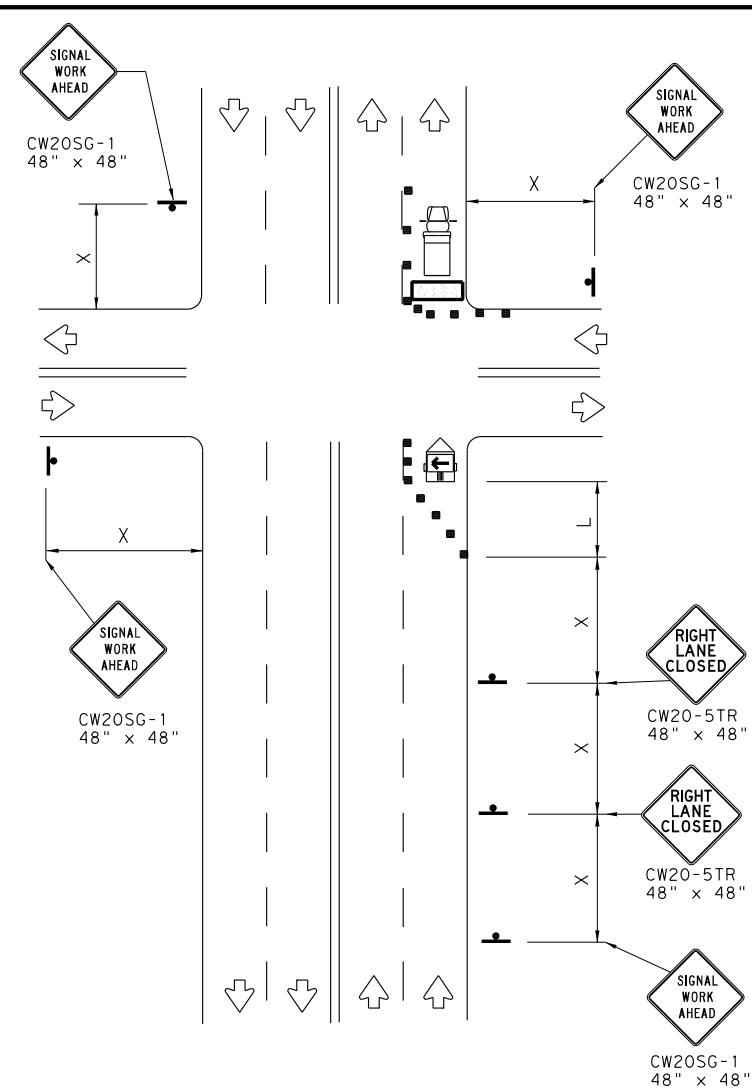

FAR SIDE RIGHT LANE CLOSURE
 SHORT DURATION OR SHORT TERM STATIONARY

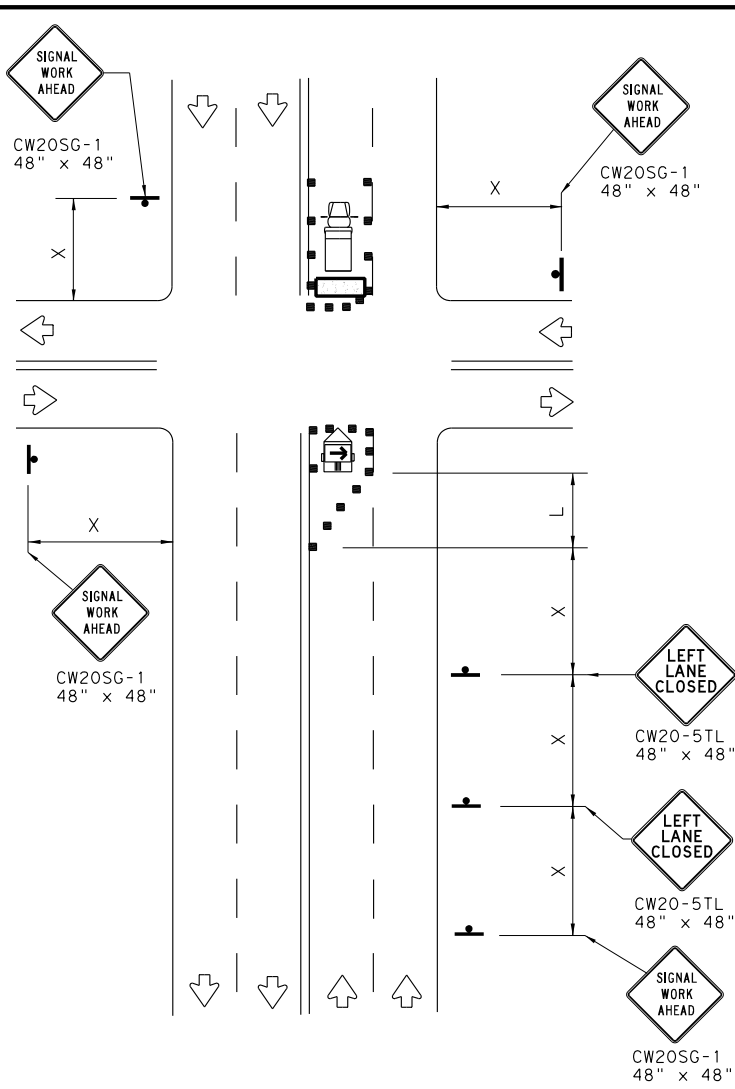

FAR SIDE LEFT LANE CLOSURE
 SHORT DURATION OR SHORT TERM STATIONARY

LEGEND			
	Type 3 Barricade		Channelizing Devices
	Heavy Work Vehicle		Truck Mounted Attenuator (TMA)
	Trailer Mounted Flashing Arrow Board		Portable Changeable Message Sign (PCMS)
	Sign		Traffic Flow
	Flag		Flagger

Posted Speed *	Formula	Minimum Desirable Taper Lengths * X			Suggested Maximum Spacing of Channelizing Devices		Minimum Sign Spacing "X" Distance	Suggested Longitudinal Buffer Space "B"
		10' Offset	11' Offset	12' Offset	On a Taper	On a Tangent		
30	$L = \frac{WS^2}{60}$	150'	165'	180'	30'	60'	120'	90'
35		205'	225'	245'	35'	70'	160'	120'
40		265'	295'	320'	40'	80'	240'	155'
45	L = WS	450'	495'	540'	45'	90'	320'	195'
50		500'	550'	600'	50'	100'	400'	240'
55		550'	605'	660'	55'	110'	500'	295'
60		600'	660'	720'	60'	120'	600'	350'
65		650'	715'	780'	65'	130'	700'	410'
70		700'	770'	840'	70'	140'	800'	475'
75		750'	825'	900'	75'	150'	900'	540'

* Conventional Roads Only
 ** Taper lengths have been rounded off.
 L=Length of Taper (FT) W=Width of Offset (FT) S=Posted Speed (MPH)

WORKERS IN BUCKET TRUCKS SHALL NOT WORK ABOVE OPEN LANES OF TRAFFIC.

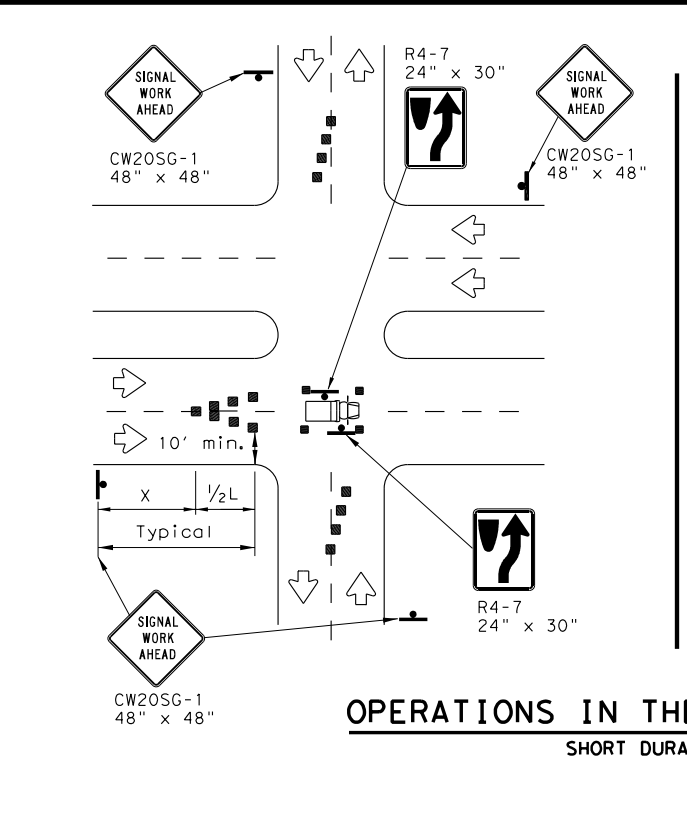

OPERATIONS IN THE INTERSECTION
 SHORT DURATION

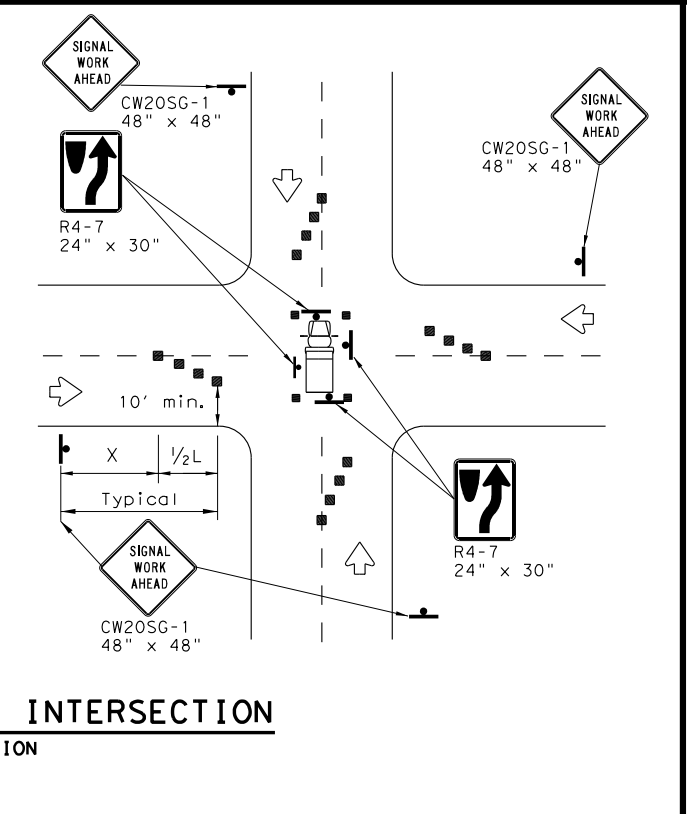

GENERAL NOTES

- The minimum size channelizing device is the 28" cone. 42" Two-piece cones, drums, vertical panels or barricades will be required when the device must be left unattended at night.
- Obstructions or hazards at the work area shall be clearly marked and delineated at all times.
- Flaggers and Flagger Symbol (CW20-7) signs may be required according to field conditions.
- Vehicles parked in roadway shall be equipped with at least two high intensity rotating, flashing, oscillating or strobe type lights.
- High level warning devices (flag trees) may be used at corners of the vehicle.
- When work operations are performed on existing signals, the signals may be placed in flashing red mode when approved by the engineer. If existing signals do not have power, All-Way Stop (R1-1 and R1-3P) signs may be implemented when approved by the engineer.
- For Short-Term Stationary work the buffer space "B" from the above table should be used if field conditions permit. For Short Duration (less than 1 hour) any buffer space provided will enhance the safety of the setup.
- The arrow board at this location may be omitted for Short Duration work if the work vehicle has an arrow board in operation. As an option, the arrow board may be placed at the end of the taper in the closed lane if space is not available at the beginning of the taper.
- Signs and devices for the NEAR SIDE LANE CLOSURE may be altered for a left lane closure by using a LEFT LANE CLOSED (CW20-5TL) and adding channelizing devices on the centerline to protect the work space from opposing traffic.



TRAFFIC SIGNAL WORK TYPICAL DETAILS

WZ(BTS-1)-13

FILE: wzbtfs-13.dgn	DN: TxDOT	CK: TxDOT	DN: TxDOT	CK: TxDOT
© TxDOT April 1992	CONT	SECT	JOB	HIGHWAY
REVISIONS				
2-98 10-99 7-13	DIST		COUNTY	SHEET NO.
4-98 3-03			BEXAR	87

DISCLAIMER: The use of this standard is governed by the "Texas Engineering Practice Act". No warranty of any kind is made by TxDOT for any purpose whatsoever. TxDOT assumes no responsibility for the conversion of this standard to other formats or for incorrect results resulting from its use.

DATE: 1/20/2023 7:07:24 PM
 FILE: K:\COSA\DoI\os\STANDARDS\TCP\wzbt-13.dgn

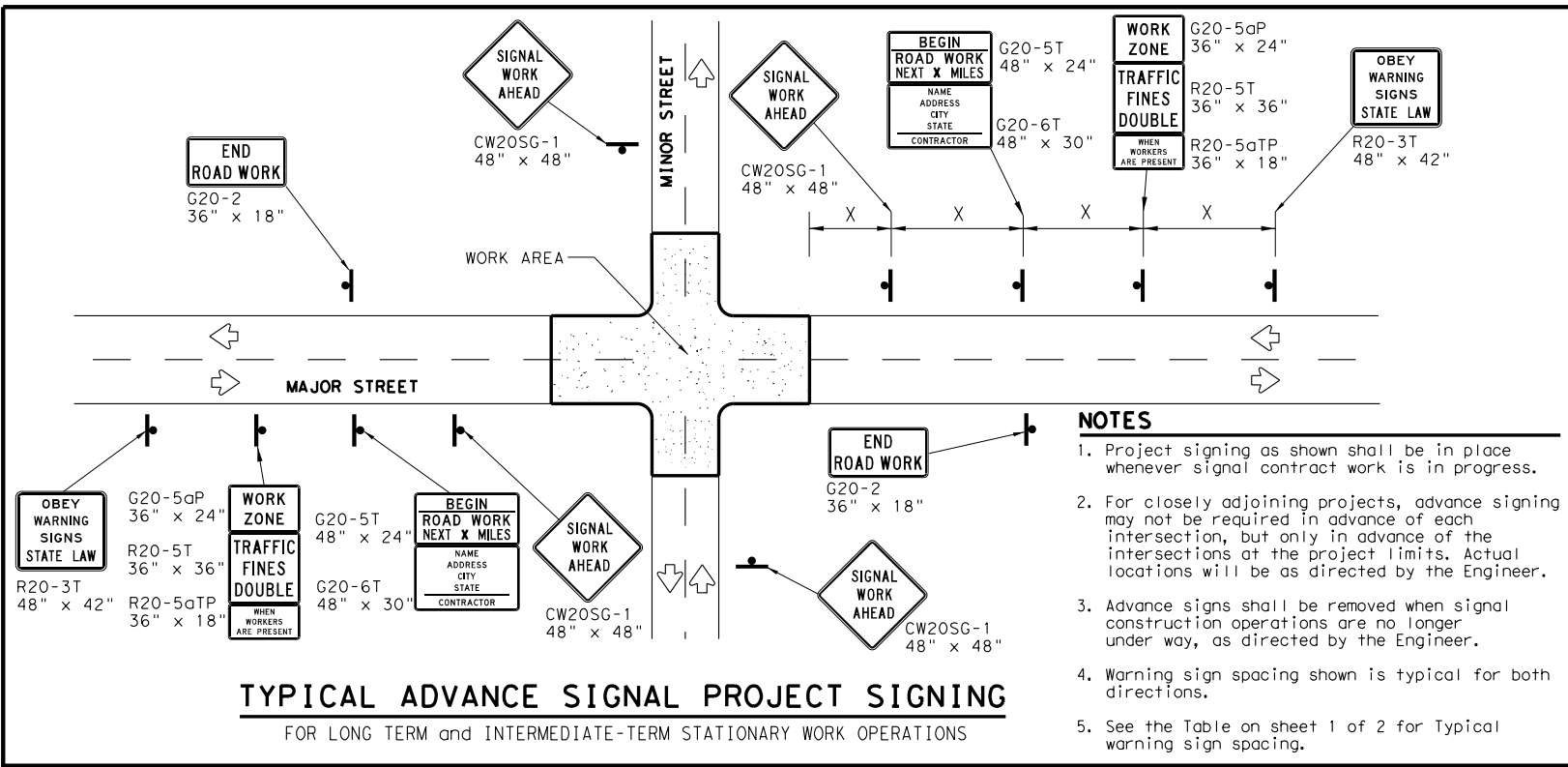

TYPICAL ADVANCE SIGNAL PROJECT SIGNING
 FOR LONG TERM and INTERMEDIATE-TERM STATIONARY WORK OPERATIONS

- NOTES**
1. Project signing as shown shall be in place whenever signal contract work is in progress.
 2. For closely adjoining projects, advance signing may not be required in advance of each intersection, but only in advance of the intersections at the project limits. Actual locations will be as directed by the Engineer.
 3. Advance signs shall be removed when signal construction operations are no longer under way, as directed by the Engineer.
 4. Warning sign spacing shown is typical for both directions.
 5. See the Table on sheet 1 of 2 for Typical warning sign spacing.

GENERAL NOTES FOR WORK ZONE SIGNS

1. Signs shall be installed and maintained in a straight and plumb condition.
2. Wooden sign posts shall be painted white.
3. Barricades shall NOT be used as sign supports.
4. Nails shall NOT be used to attach signs to any support.
5. All signs shall be installed in accordance with the plans or as directed by the Engineer.
6. The Contractor shall furnish the sign design shown in the plans or in the "Standard Highway Sign Designs for Texas" (SHSD).
7. The Contractor shall furnish sign supports and substrates listed in the "Compliant Work Zone Traffic Control Device List" (CWZTCD), installed as per the manufacturer's recommendations.
8. Temporary signs that have damaged or cracked substrates and/or damaged or marred reflective sheeting shall be replaced as directed by the Engineer.
9. Identification markings may be shown only on the back of the sign substrate. The maximum height of letters and/or company logos used for identification shall be 1".
10. Damaged wood posts shall be replaced. Splicing wood posts will not be allowed.

DURATION OF WORK

1. Work zone durations are defined in Part 6, Section 60.02 of the Texas Manual on Uniform Traffic Control Devices (TMUTCD).

SIGN MOUNTING HEIGHT

1. Sign height of Long-term/Intermediate-term warning signs shall be as shown on Figure 6F-1 of the TMUTCD.
2. Sign height of Short-term/Short Duration warning signs shall be as shown on Figure 6F-2 of the TMUTCD.
3. Regulatory signs shall be mounted at least 7 feet, but not more than 9 feet, above the paved surface regardless of work duration.

REMOVING OR COVERING

1. When sign messages may be confusing or do not apply, the signs shall be removed or completely covered, unless otherwise approved by the Engineer.
2. When signs are covered, the material used shall be opaque, such as heavy mil black plastic, or other materials which will cover the entire sign face and maintain their opaque properties under automobile headlights at night without damaging the sign sheeting. Burlap, or heavy materials such as plywood or aluminum shall not be used to cover signs.
3. Duct tape or other adhesive material shall NOT be affixed to a sign face.
4. Signs and anchor stubs shall be removed and holes back filled upon completion of the work.

REFLECTIVE SHEETING

1. All signs shall be retroreflective and constructed of sheeting meeting the requirements of the DMS and color usage table shown on this sheet.

SIGN SUPPORT WEIGHTS

1. Weights used to keep signs from turning over should be sandbags filled with dry, cohesionless material.
2. The sandbags will be tied shut to keep the sand from spilling and to maintain a constant weight.
3. Rock, concrete, iron, steel or other solid objects will not be permitted for use as sign support weights.
4. Sandbags should weigh a minimum of 35 lbs and a maximum of 50 lbs.
5. Sandbags should be made of a durable material that tears upon vehicular impact. Rubber, such as tire inner tubes, shall not be used.
6. Rubber ballasts designed for channelizing devices should not be used for ballast on portable sign supports. Sign supports designed and manufactured with rubber bases may be used when shown on the CWZTCD list.
7. Sandbags shall only be placed along or laid over the base supports of the traffic control device and shall not be suspended above ground level or hung with rope, wire, chains or other fasteners. Sandbags shall be placed along the length of the skids to weigh down the sign support.
8. Sandbags shall NOT be placed under the skid and shall not be used to level sign supports placed on slopes.

LEGEND	
	Sign
	Channelizing Devices
	Type 3 Barricade

DEPARTMENTAL MATERIAL SPECIFICATIONS

SIGN FACE MATERIALS	DMS-8300
FLEXIBLE ROLL-UP REFLECTIVE SIGNS	DMS-8310

COLOR	USAGE	SHEETING MATERIAL
ORANGE	BACKGROUND	TYPE B _{FL} OR TYPE C _{FL} SHEETING
WHITE	BACKGROUND	TYPE A SHEETING
BLACK	LEGEND & BORDERS	ACRYLIC NON-REFLECTIVE SHEETING

Only pre-qualified products shall be used. A copy of the "Compliant Work Zone Traffic Control Devices List" (CWZTCD) describes pre-qualified products and their sources and may be found at the following web address:
http://www.txdot.gov/txdot_library/publications/construction.htm

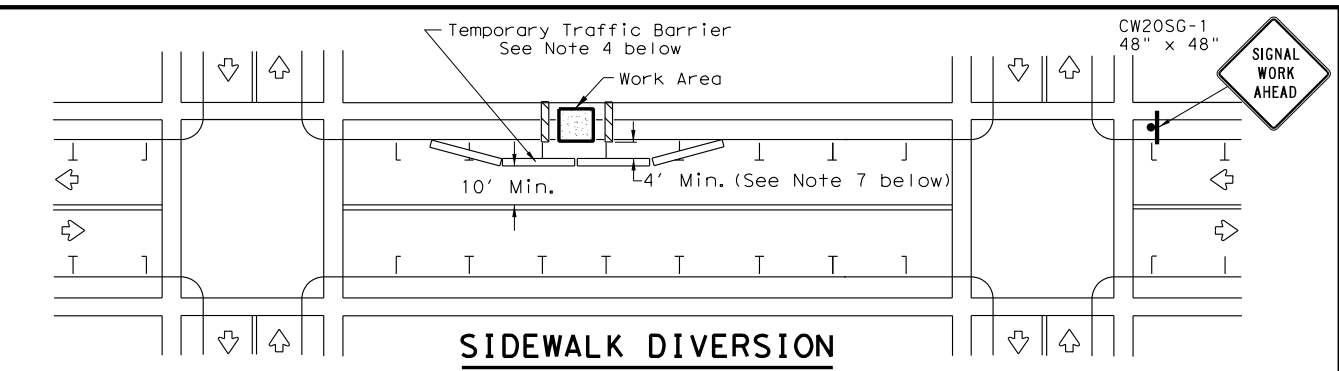

SIDEWALK DIVERSION

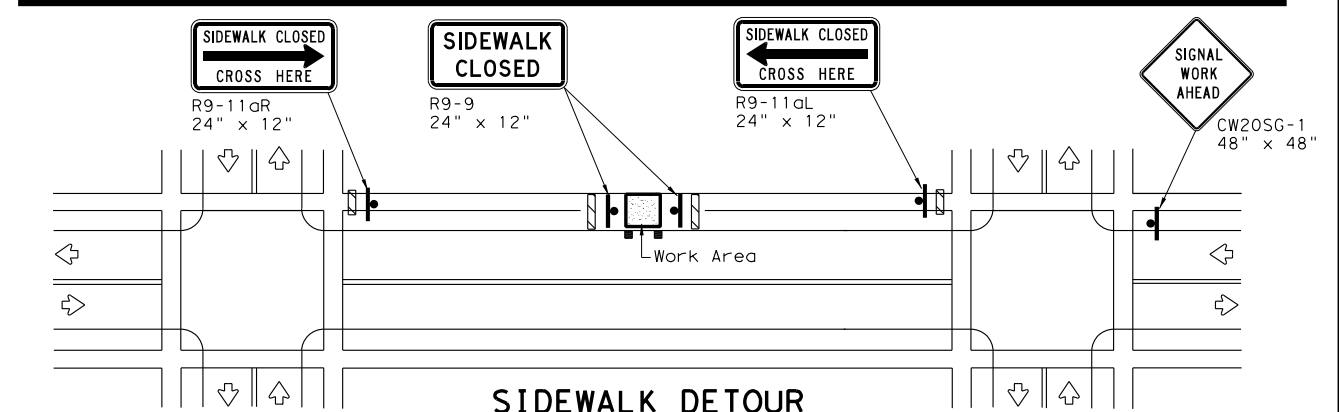

SIDEWALK DETOUR

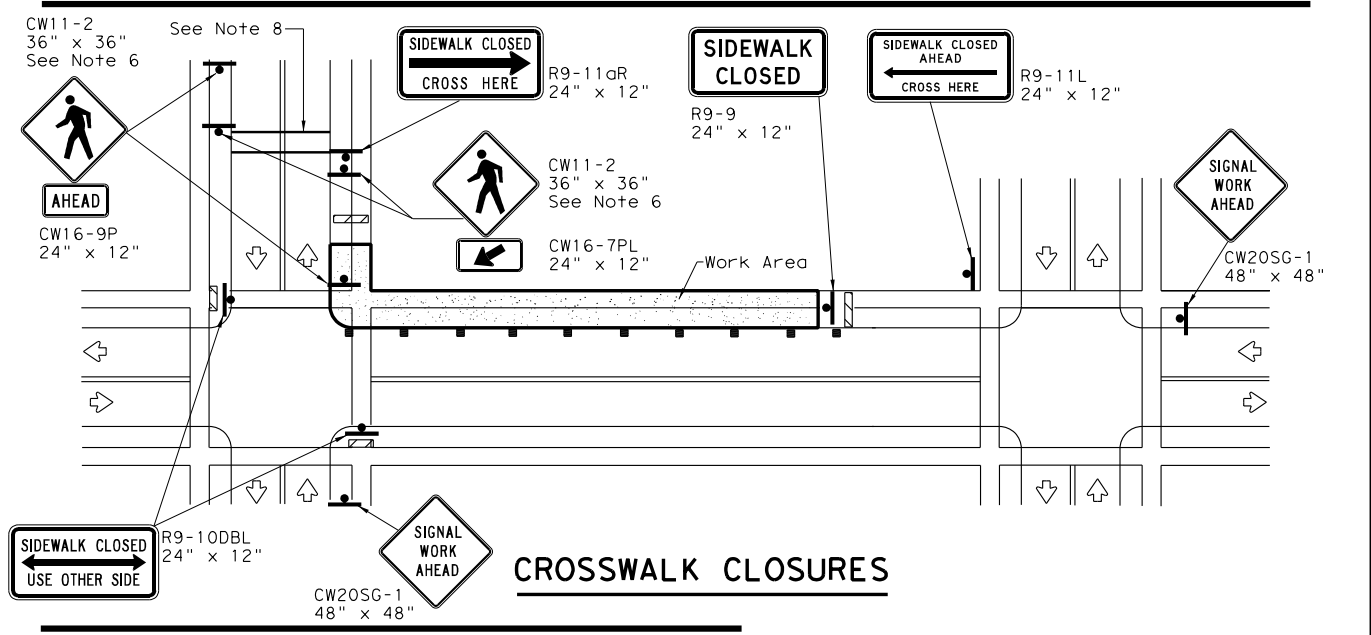

CROSSWALK CLOSURES

PEDESTRIAN CONTROL

1. Holes, trenches or other hazards shall be adequately protected by covering, delineating or surrounding the hazard with orange plastic pedestrian fencing or longitudinal channelizing devices, or as directed by the Engineer.
2. "CROSSWALK CLOSURES" as detailed above will require the Engineer's approval prior to installation.
3. R9 series signs shown may be placed on supports detailed on the BC standards or CWZTCD list, or when fabricated from approved lightweight plastic substrates, they may be mounted on top of a plastic drum at or near the location shown.
4. For speeds less than 45 mph longitudinal channelizing devices may be used instead of traffic barriers when approved by the Engineer. Attenuation of blunt ends and installation of water filled devices shall be as per BC(9) and manufacturer's recommendations.
5. Location of devices are for general guidance. Actual device spacing and location must be field adjusted to meet actual conditions.
6. Where pedestrians with visual disabilities normally use the closed sidewalk Detectable Pedestrian Barricades should be used instead of the Type 3 Barricades shown.
7. The width of existing sidewalk should be maintained if practical.
8. Pavement markings for mid-block crosswalks shall be paid for under the appropriate bid items.
9. When crosswalks or other pedestrian facilities are closed or relocated, temporary facilities shall be detectable and shall include accessibility features consistent with the features present in the existing pedestrian facility.

SHEET 2 OF 2

Texas Department of Transportation
 Traffic Operations Division Standard

TRAFFIC SIGNAL WORK BARRICADES AND SIGNS

WZ (BTS-2) - 13

FILE:	wzbt-13.dgn	DN:	TxDOT	CK:	TxDOT	DW:	TxDOT	CK:	TxDOT
© TxDOT	April 1992	CONT	SECT	JOB	HIGHWAY				
REVISIONS				COSA					
2-98	10-99	7-13	DIST		COUNTY	SHEET NO.			
4-98	3-03			BEXAR	88				

DISCLAIMER: The use of this standard is governed by the "Texas Engineering Practice Act". No warranty of any kind is made by TxDOT for any purpose whatsoever. TxDOT assumes no responsibility for the conversion of this standard to other formats or for incorrect results or damages resulting from its use.

DATE: 1/20/2023 7:07:27 PM
 FILE: K:\COSA\DoI\os\STANDARDS\TCP\wzstpm-13.dgn

WORK ZONE SHORT TERM PAVEMENT MARKINGS DETAILS

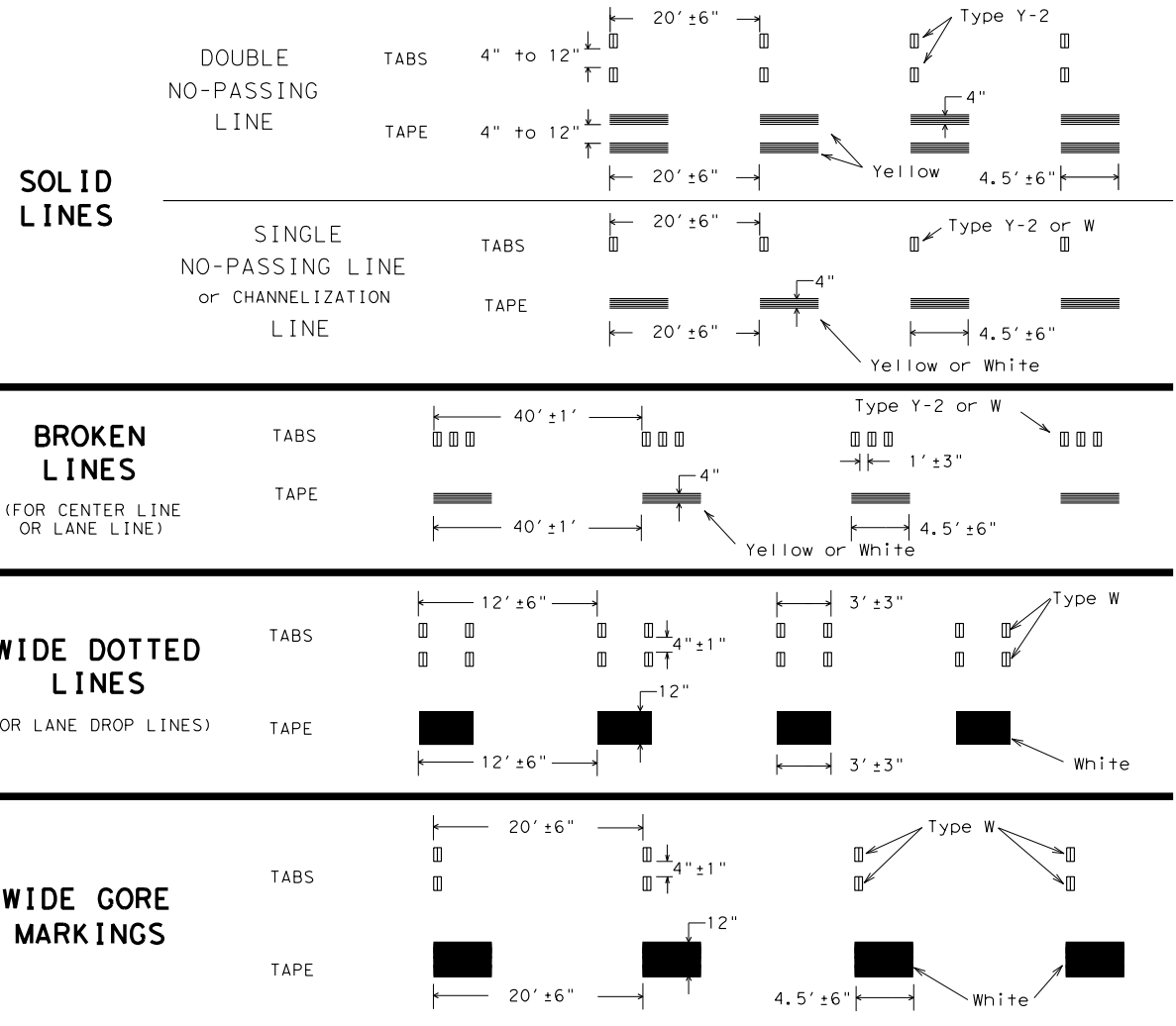

NOTES:

- Short term pavement markings may be prefabricated markings (stick down tape) or temporary flexible-reflective roadway marker tabs unless otherwise specified elsewhere in plans.
- Short term pavement markings shall NOT be used to simulate edge lines.
- Dimensions indicated on this sheet are typical and approximate. Variations in size and height may occur between markers or devices made by manufacturers, by as much as 1/4 inch, unless otherwise noted.
- Temporary flexible-reflective roadway marker tabs will require normal maintenance replacement when used on roadways with an ADT per lane of up to 7500 vehicles with no more than 10% truck mix. When roadways exceed these values, additional maintenance replacement of devices should be planned.
- No segment of roadway open to traffic shall remain without permanent pavement markings for a period greater than 14 calendar days. The Contractor will be responsible for maintaining short term pavement markings until permanent pavement markings are in place. When the Contractor is responsible for placement of permanent pavement markings, no segment of roadway shall remain without permanent pavement markings for a period greater than 14 calendar days unless weather conditions prohibit placement. Permanent pavement markings shall be placed as soon as weather permits.
- For two lane, two-way roadways, DO NOT PASS signs shall be erected to mark the beginning of sections where passing is prohibited and PASS WITH CARE signs shall be erected to mark the beginning of sections where passing is permitted. Signs shall be in accordance with the "Texas Manual on Uniform Traffic Control Devices" (TMUTCD) and may be used to indicate the limits of no-passing zones for up to 14 calendar days. Permanent pavement markings should then be placed.
- For low volume two lane, two-way roadways of 4000 ADT or less, no-passing lines may be omitted when approved by the Engineer. DO NOT PASS and PASS WITH CARE signs shall be erected (see note 6).
- For exit gores where a lane is being dropped place wide gore markings or retroreflective channelizing devices to guide motorist through the exit. If channelizing devices are to be used it should be noted elsewhere in the plans. One piece cones are not allowed for this purpose.

TEMPORARY FLEXIBLE, REFLECTIVE ROADWAY MARKER TABS (TABS)

- Temporary flexible-reflective roadway marker tabs detailed on this sheet will be designated Type Y-2 (two amber reflective surfaces with yellow body); Type Y (one amber reflective surface with yellow body); and Type W (one white or silver reflective surface with white body). Additional details may be found on BC(11).
- Tabs shall meet requirements of Departmental Material Specification DMS-8242.
- When dry, tabs shall be visible for a minimum distance of 200 feet during normal daylight hours and when illuminated by automobile low-beam head light at night, unless sight distance is restricted by roadway geometrics.
- No two consecutive tabs nor four tabs per 1000 feet of line shall be missing or fail to meet the visual performance requirements of Note 3.

WORK ZONE SHORT TERM PAVEMENT MARKINGS PATTERNS

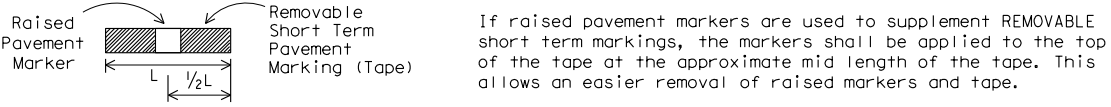
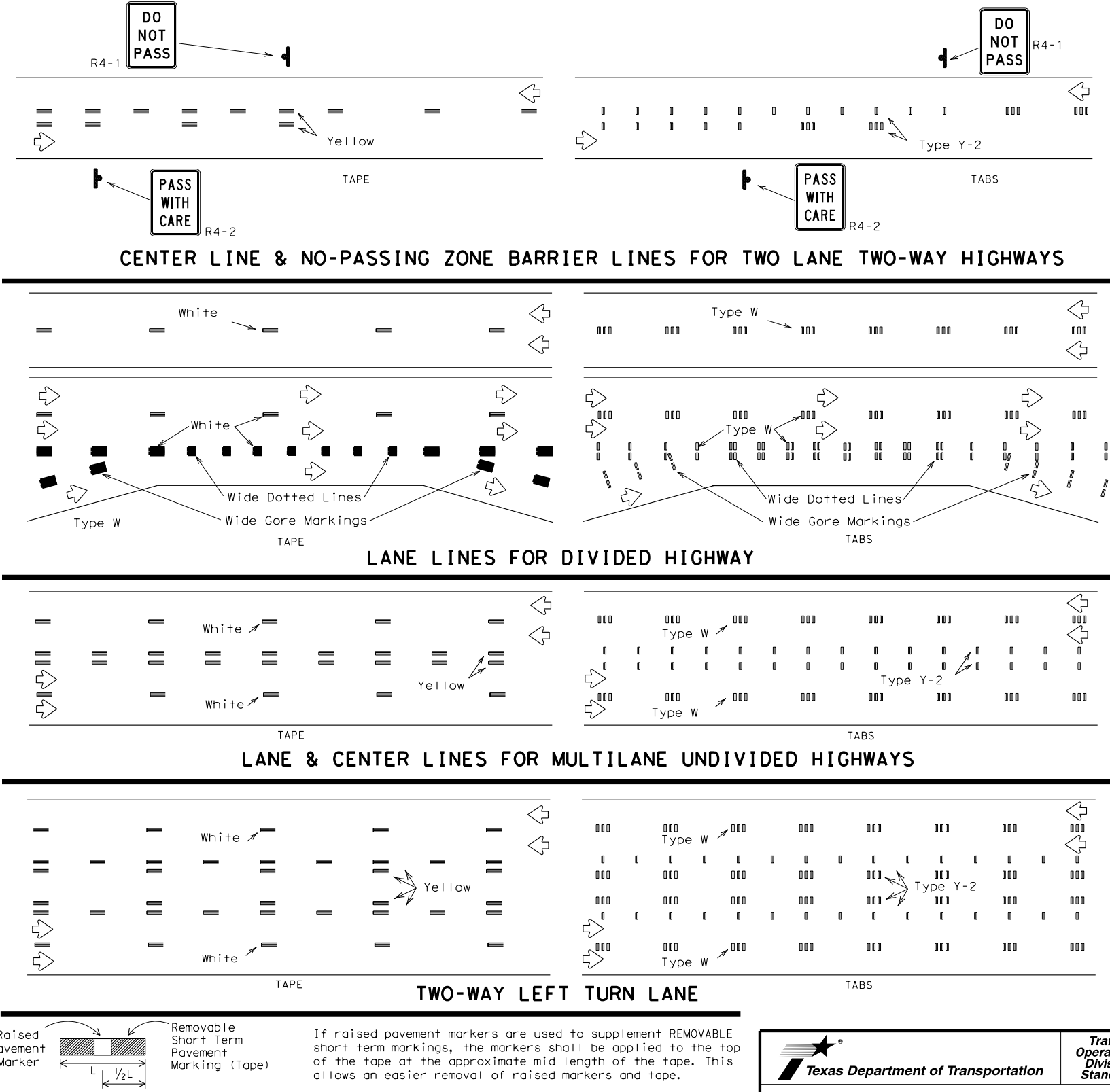

PREFABRICATED PAVEMENT MARKINGS

- Temporary Removable Prefabricated Pavement Markings shall meet the requirements of DMS-8241.
- Non-removable Prefabricated Pavement Markings shall meet the requirements of either DMS-8240 "Permanent Prefabricated Pavement Markings" or DMS-8243 "Temporary Construction-Grade Prefabricated Pavement Markings."

RAISED PAVEMENT MARKERS

- All raised pavement markers used for work zone markings shall meet the requirements of Item 672, "RAISED PAVEMENT MARKERS" and DMS-4200.

DEPARTMENTAL MATERIAL SPECIFICATIONS (DMS) & MATERIAL PRODUCER LISTS (MPL)

- DMSs referenced above can be found along with embedded links to their respective MPLs at the following website:
http://www.txdot.gov/business/contractors_consultants/material_specifications/default.htm



WORK ZONE SHORT TERM PAVEMENT MARKINGS

WZ (STPM) - 13

FILE:	wzstpm-13.dgn	DN:	TxDOT	CK:	TxDOT	DN:	TxDOT	CK:	TxDOT
© TxDOT	April 1992	CONT:		SECT:		JOB:		HIGHWAY:	
REVISIONS		DIST:		COUNTY:		SHEET NO.:			
1-97				BEXAR		89			
3-03									
7-13									

DISCLAIMER: The use of this standard is governed by the "Texas Engineering Practice Act". No warranty of any kind is made by TxDOT for any purpose whatsoever. TxDOT assumes no responsibility for the conversion of this standard to other formats or for incorrect results or damages resulting from its use.

DATE: 1/20/2023 7:07:30 PM
 FILE: K:\COSA\DoI\osca\STANDARDS\TCP\wz1-13.dgn

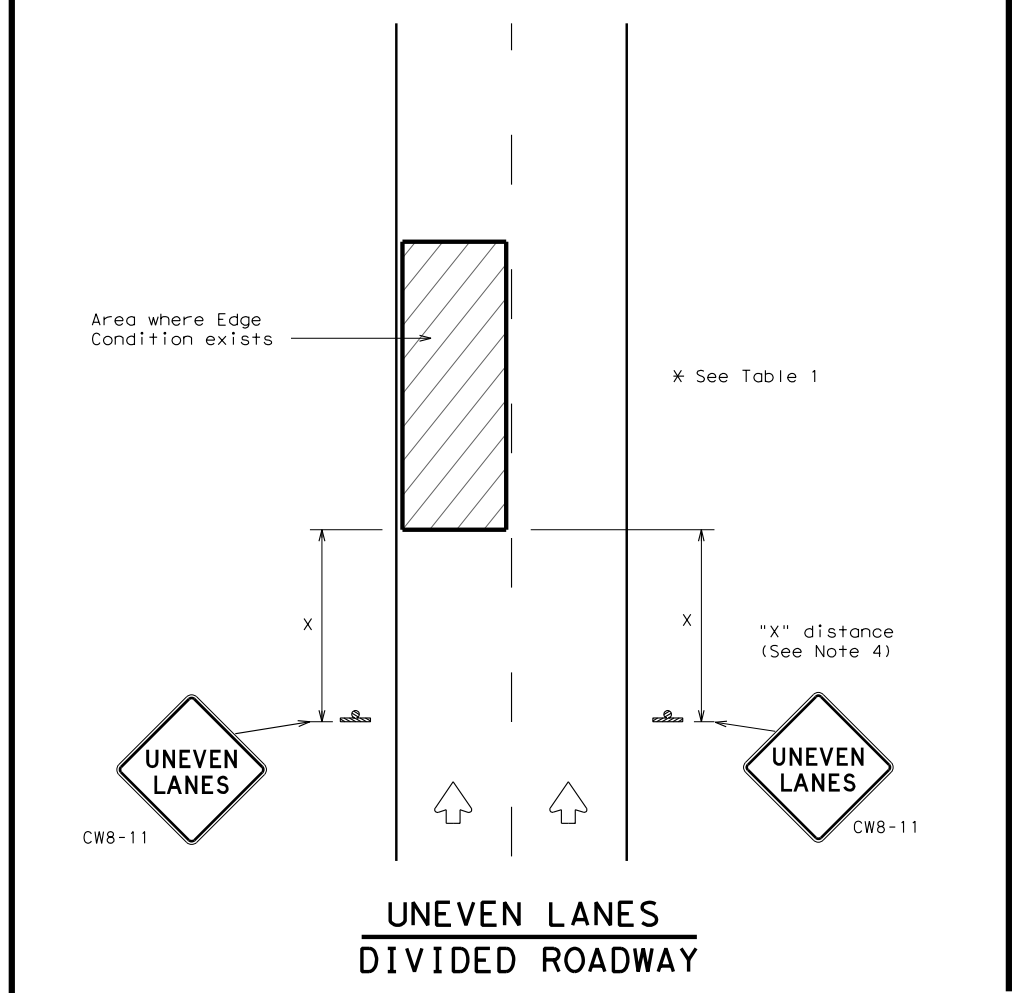
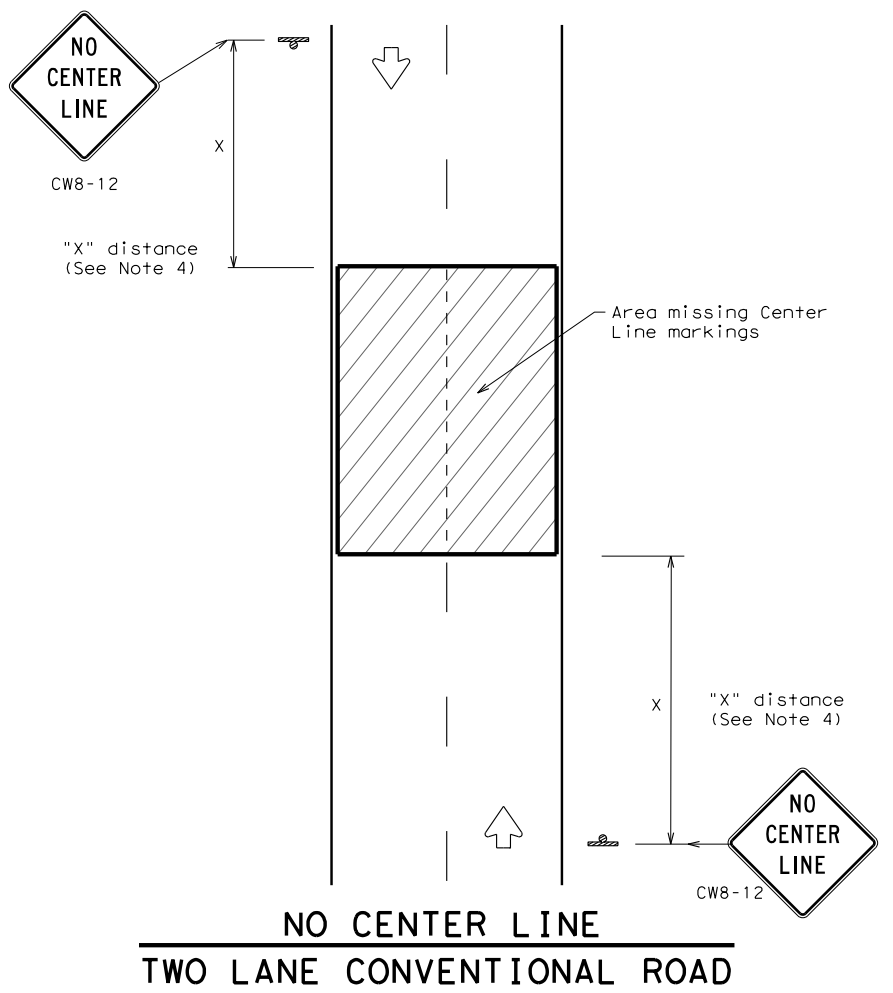
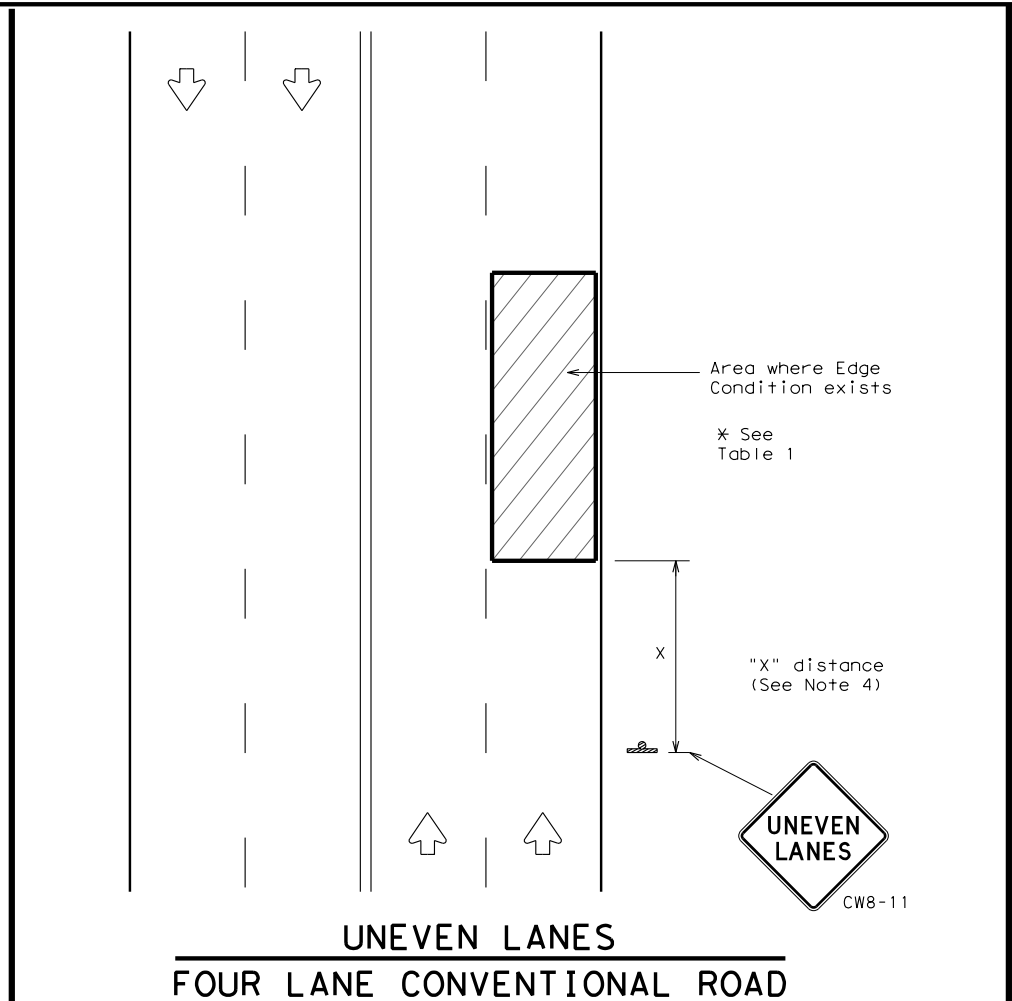
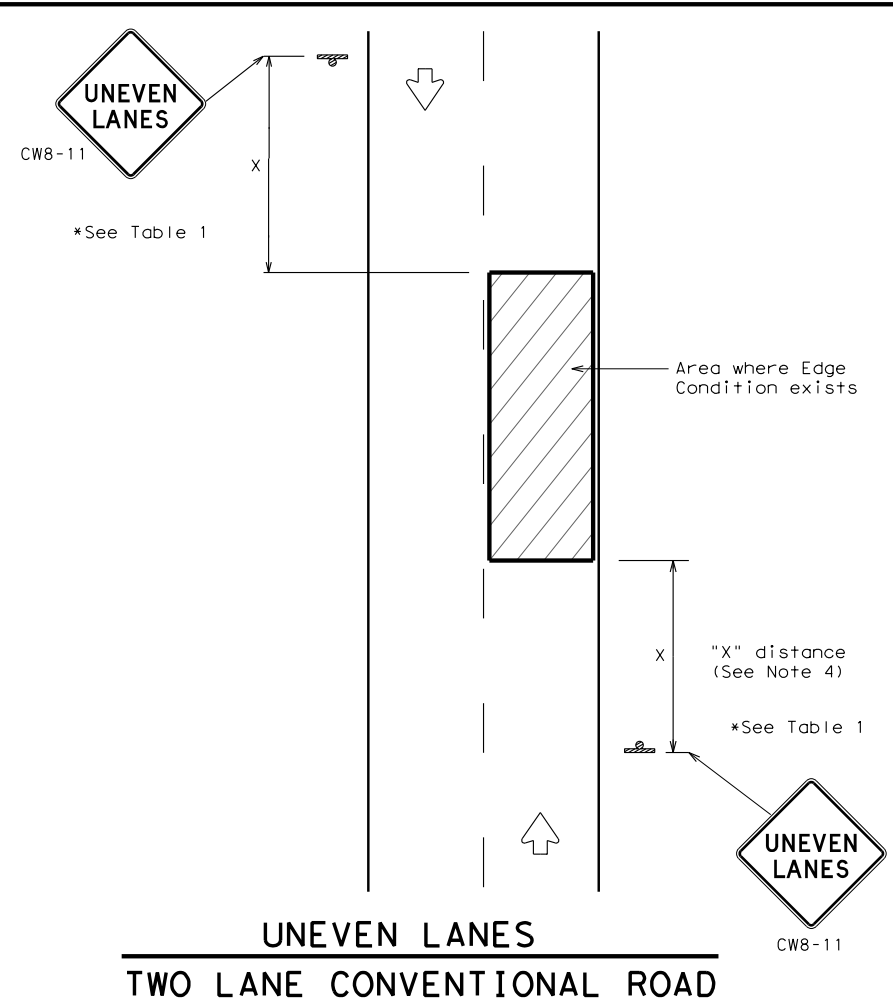

DEPARTMENTAL MATERIAL SPECIFICATIONS	
PERMANENT PREFABRICATED PAVEMENT MARKINGS	DMS-8240
TEMPORARY (REMOVABLE) PREFABRICATED PAVEMENT MARKINGS	DMS-8241
SIGN FACE MATERIALS	DMS-8300

COLOR	USAGE	SHEETING MATERIAL
ORANGE	BACKGROUND	TYPE B _{FL} OR TYPE C _{FL} SHEETING
BLACK	LEGEND & BORDERS	ACRYLIC NON-REFLECTIVE SHEETING

GENERAL NOTES

1. If spalling or holes occur, ROUGH ROAD (CW8-8) signs should be placed in advance of the condition and be repeated every two miles where the condition persists.
2. UNEVEN LANES (CW8-11) signs shall be installed in advance of the condition and repeated every mile. Signs installed along the uneven lane condition may be supplemented with the NEXT XX MILES (CW7-3aP) plaque or Advisory Speed (CW13-1P) plaque.
3. NO CENTER LINE (CW8-12) signs and temporary pavement markings as per the WZ(STPM) standard shall be installed if yellow centerlines separating two way traffic are obscured or obliterated. Repeat NO CENTER LINE signs every two miles where the center line markings are not in place. The signs and markings shall remain in place until permanent pavement markings are installed.
4. Signs shall be spaced at the distances recommended as per BC standards.
5. Additional signs may be required as directed by the Engineer. Signs shall remain in place until final surface is applied. Signs shall be considered subsidiary to Item 502 "BARRICADES, SIGNS AND TRAFFIC HANDLING."
6. Signs shall be fabricated and mounted on supports as shown on the BC standards and/or listed on the "Compliant Work Zone Traffic Control Devices" list.
7. Short term markings shall not be used to simulate edge lines.
8. All signs shall be constructed in accordance with the details found in the "Standard Highway Sign Designs for Texas," latest edition.

Edge Condition	Edge Height (D)	* Warning Devices
①	Less than or equal to: 1/4" (maximum-planing) 1/2" (typical-overlay)	Sign: CW8-11
②	Less than or equal to 3"	Sign: CW8-11
③	Distance "D" may be a maximum of 3" if uneven lanes with edge condition 2 or 3 are open to traffic after work operations cease. Uneven lanes should not be open to traffic when "D" is greater than 3".	

TRAFFIC CONTROL DURING PLANING, OVERLAY AND LEVELING OPERATIONS ARE SHOWN ELSEWHERE IN THE PLANS.

MINIMUM WARNING SIGN SIZE	
Conventional roads	36" x 36"
Freeways/expressways, divided roadways	48" x 48"

Texas Department of Transportation

Traffic Operations Division Standard

SIGNING FOR UNEVEN LANES

WZ (UL) - 13

FILE: WZUL-13.dgn	DN: TxDOT	CK: TxDOT	DN: TxDOT	CK: TxDOT
© TxDOT April 1992	CONT	SECT	JOB	HIGHWAY
REVISIONS				
8-95 2-98 7-13	DIST		COUNTY	SHEET NO.
1-97 3-03			BEXAR	90

DISCLAIMER: The use of this standard is governed by the "Texas Engineering Practice Act". No warranty of any kind is made by TxDOT for any purpose whatsoever. TxDOT assumes no responsibility for the conversion of this standard to other formats or for incorrect results or damages resulting from its use.

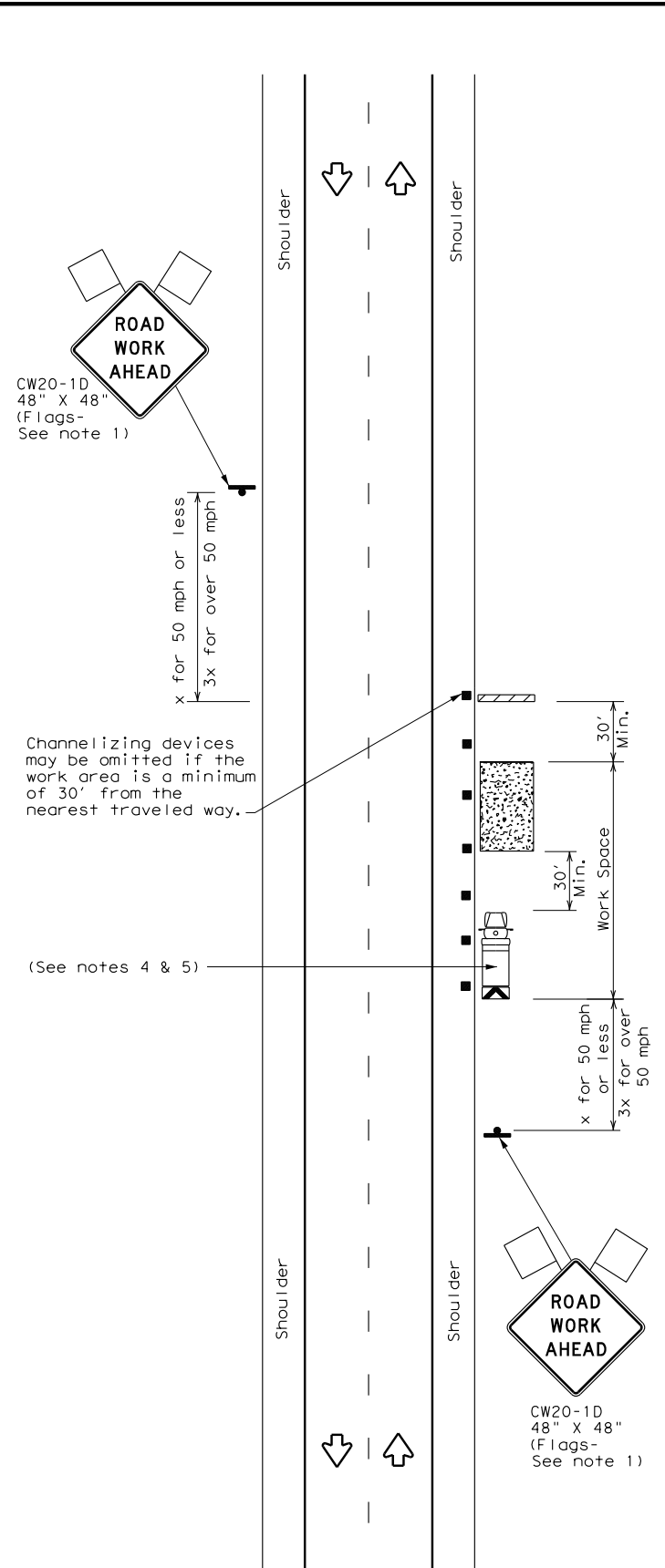

TCP (2-1a)

WORK SPACE NEAR SHOULDER
 Conventional Roads

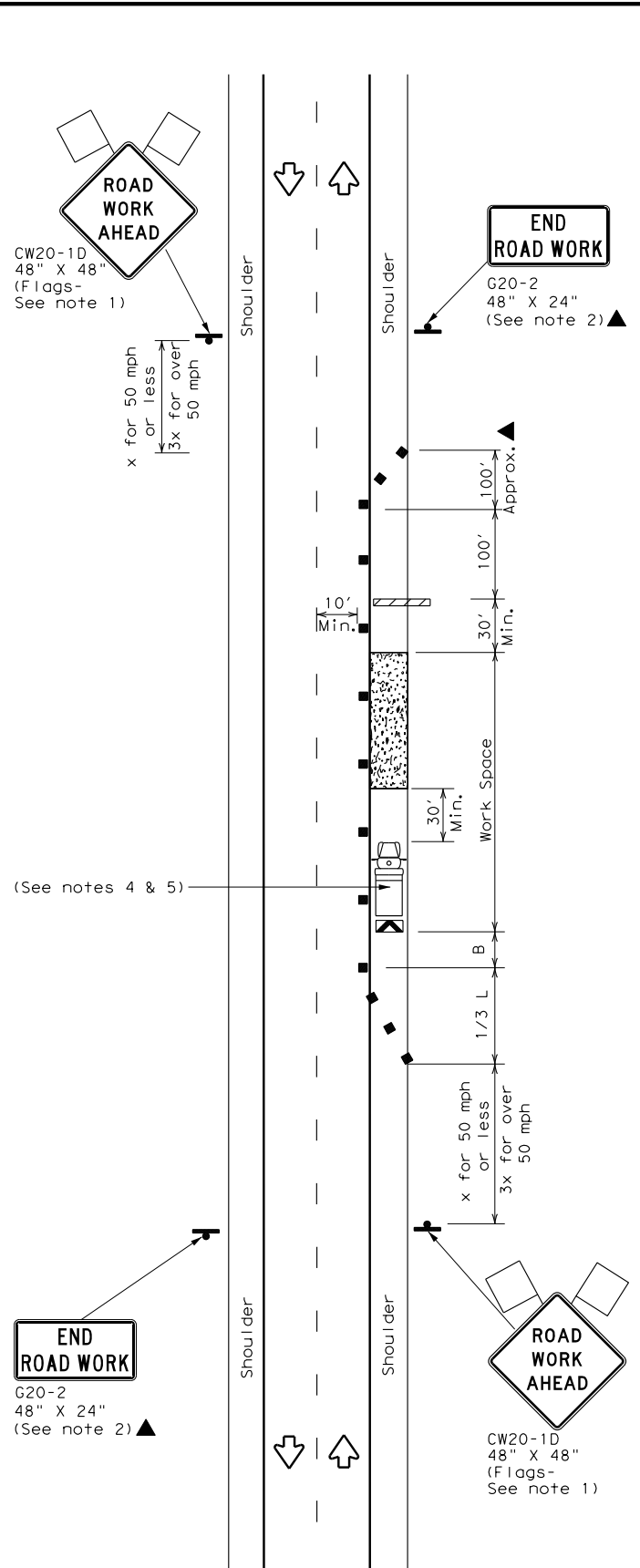

TCP (2-1b)

WORK SPACE ON SHOULDER
 Conventional Roads

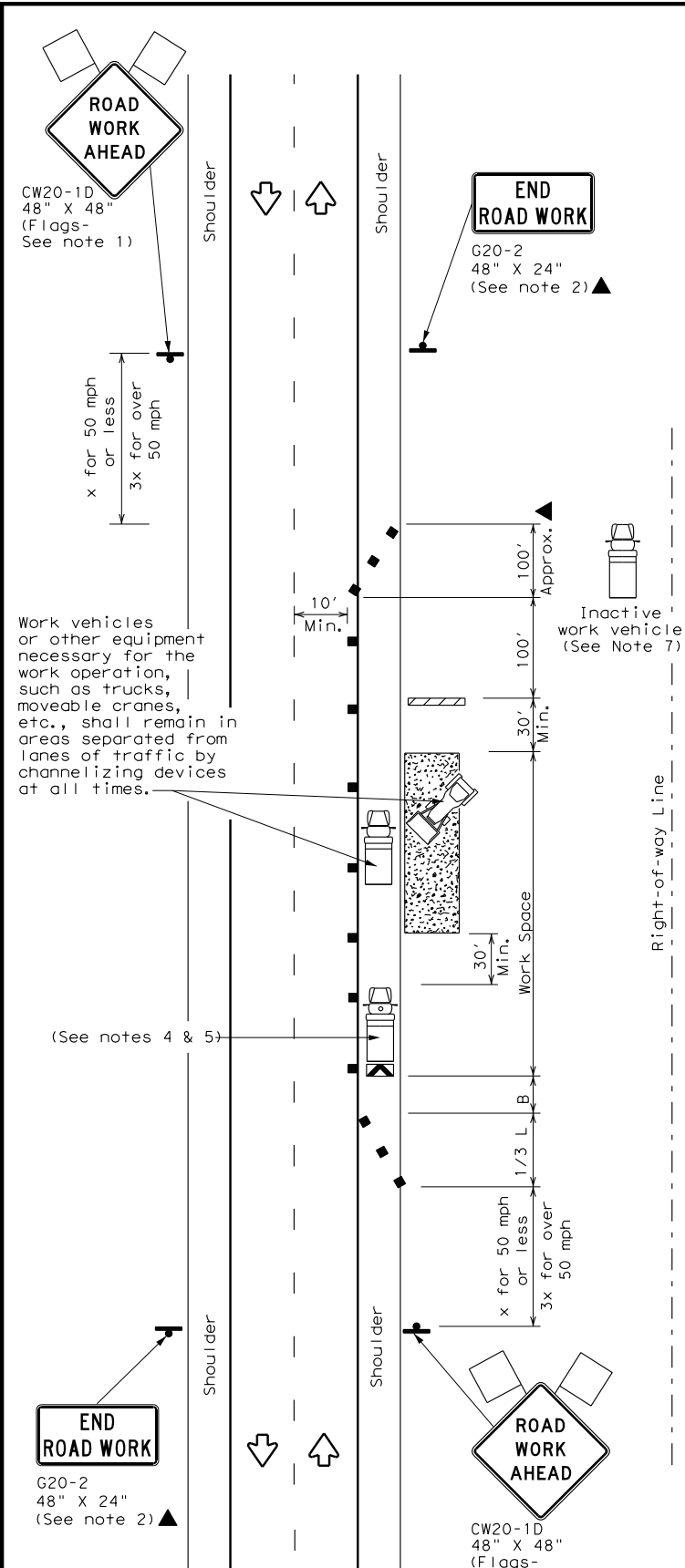

TCP (2-1c)

WORK VEHICLES ON SHOULDER
 Conventional Roads

LEGEND			
	Type 3 Barricade		Channelizing Devices
	Heavy Work Vehicle		Truck Mounted Attenuator (TMA)
	Trailer Mounted Flashing Arrow Board		Portable Changeable Message Sign (PCMS)
	Sign		Traffic Flow
	Flag		Flagger

Posted Speed *	Formula	Minimum Desirable Taper Lengths **			Suggested Maximum Spacing of Channelizing Devices		Minimum Sign Spacing "x" Distance	Suggested Longitudinal Buffer Space "B"
		10' Offset	11' Offset	12' Offset	On a Taper	On a Tangent		
30	$L = \frac{WS^2}{60}$	150'	165'	180'	30'	60'	120'	90'
35		205'	225'	245'	35'	70'	160'	120'
40		265'	295'	320'	40'	80'	240'	155'
45	L = WS	450'	495'	540'	45'	90'	320'	195'
50		500'	550'	600'	50'	100'	400'	240'
55		550'	605'	660'	55'	110'	500'	295'
60		600'	660'	720'	60'	120'	600'	350'
65		650'	715'	780'	65'	130'	700'	410'
70		700'	770'	840'	70'	140'	800'	475'
75		750'	825'	900'	75'	150'	900'	540'

* Conventional Roads Only
 ** Taper lengths have been rounded off.
 L=Length of Taper (FT) W=Width of Offset (FT) S=Posted Speed (MPH)

TYPICAL USAGE				
MOBILE	SHORT DURATION	SHORT TERM STATIONARY	INTERMEDIATE TERM STATIONARY	LONG TERM STATIONARY
	✓	✓	✓	✓

- GENERAL NOTES**
- Flags attached to signs where shown, are REQUIRED.
 - All traffic control devices illustrated are REQUIRED, except those denoted with the triangle symbol may be omitted when stated in the plans, or for routine maintenance work, when approved by the Engineer.
 - Stockpiled material should be placed a minimum of 30 feet from nearest traveled way.
 - Shadow Vehicle with TMA and high intensity rotating, flashing, oscillating or strobe lights. A Shadow Vehicle with a TMA should be used anytime it can be positioned 30 to 100 feet in advance of the area of crew exposure without adversely affecting the performance or quality of the work. If workers are no longer present but road or work conditions require the traffic control to remain in place, Type 3 Barricades or other channelizing devices may be substituted for the Shadow Vehicle and TMA.
 - Additional Shadow Vehicles with TMAs may be positioned off the paved surface, next to those shown in order to protect a wider work space.
 - See TCP(5-1) for shoulder work on divided highways, expressways and freeways.
 - Inactive work vehicles or other equipment should be parked near the right-of-way line and not parked on the paved shoulder.
 - CW21-5 "SHOULDER WORK" signs may be used in place of CW20-1D "ROAD WORK AHEAD" signs for shoulder work on conventional roadways.



TRAFFIC CONTROL PLAN
CONVENTIONAL ROAD
SHOULDER WORK

TCP (2-1) - 18

FILE: tcp2-1-18.dgn	DN:	CK:	DW:	CK:
© TxDOT December 1985	CONT	SECT	JOB	HIGHWAY
REVISIONS				
2-94 4-98	COSA			
8-95 2-12	DIST COUNTY SHEET NO.			
1-97 2-18	BEXAR 91			

DISCLAIMER: The use of this standard is governed by the "Texas Engineering Practice Act". No warranty of any kind is made by TxDOT for any purpose whatsoever. TxDOT assumes no responsibility for the conversion of this standard to other formats or for incorrect results or damages resulting from its use.

DATE: 1/20/2023 7:07:35 PM
 FILE: K:\COSA\DoI\orosa\STANDARDS\TCP\tcp2-2.dgn

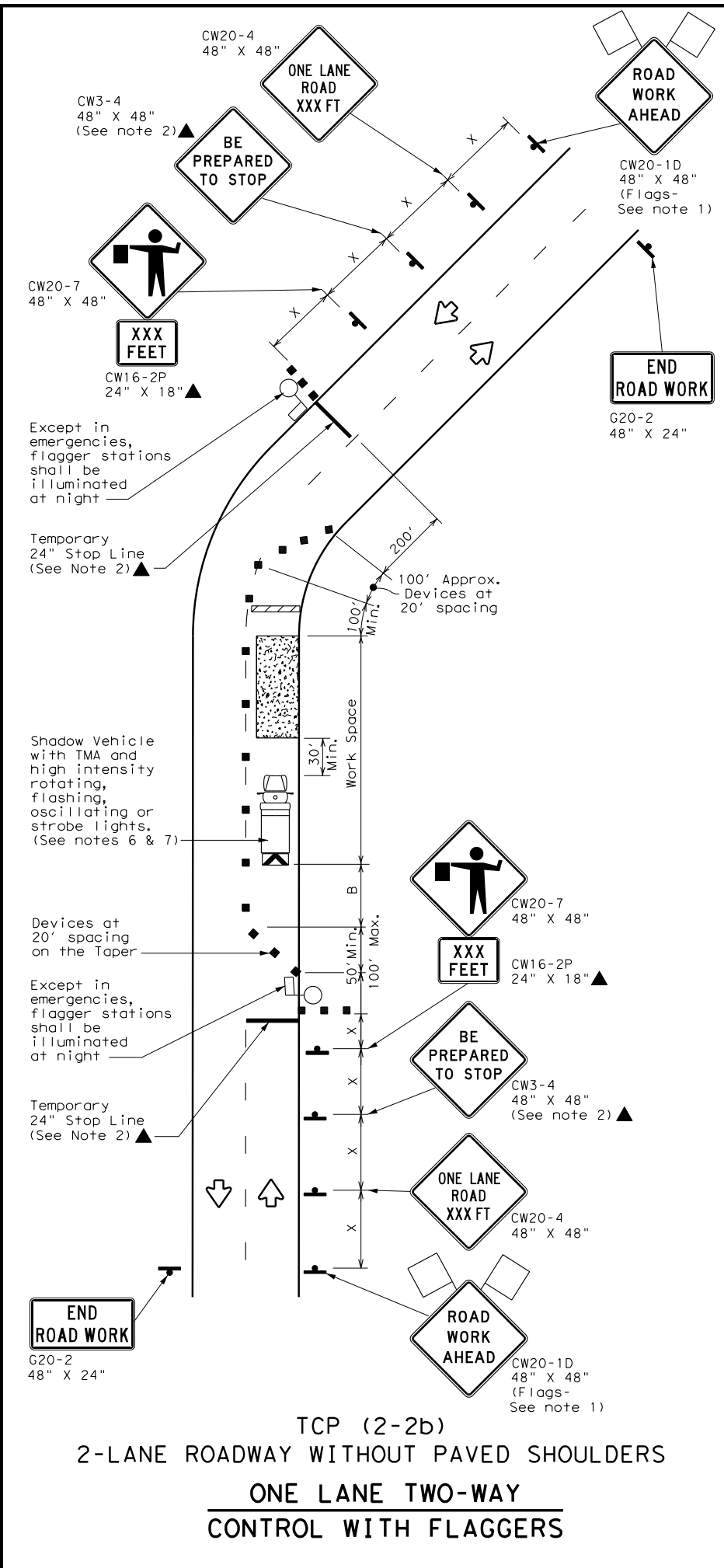
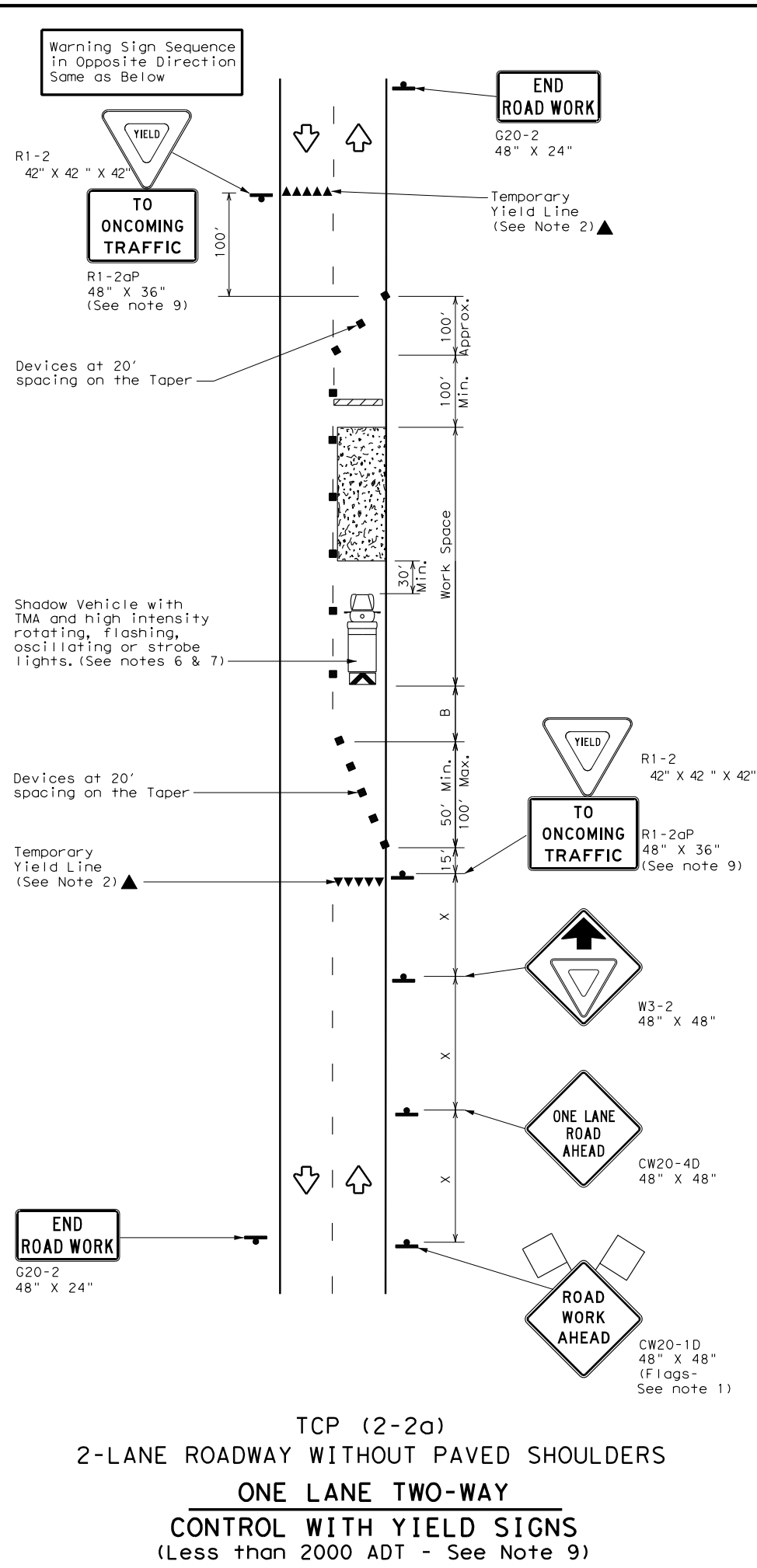

LEGEND

	Type 3 Barricade		Channelizing Devices
	Heavy Work Vehicle		Truck Mounted Attenuator (TMA)
	Trailer Mounted Flashing Arrow Board		Portable Changeable Message Sign (PCMS)
	Sign		Traffic Flow
	Flag		Flagger

Posted Speed *	Formula	Minimum Desirable Taper Lengths **			Suggested Maximum Spacing of Channelizing Devices		Minimum Sign Spacing "x" Distance	Suggested Longitudinal Buffer Space "B"	Stopping Sight Distance
		10' Offset	11' Offset	12' Offset	On a Taper	On a Tangent			
30	L = WS ² / 60	150'	165'	180'	30'	60'	120'	90'	200'
35		205'	225'	245'	35'	70'	160'	120'	250'
40		265'	295'	320'	40'	80'	240'	155'	305'
45	L = WS	450'	495'	540'	45'	90'	320'	195'	360'
50		500'	550'	600'	50'	100'	400'	240'	425'
55		550'	605'	660'	55'	110'	500'	295'	495'
60		600'	660'	720'	60'	120'	600'	350'	570'
65		650'	715'	780'	65'	130'	700'	410'	645'
70		700'	770'	840'	70'	140'	800'	475'	730'
75		750'	825'	900'	75'	150'	900'	540'	820'

* Conventional Roads Only
 ** Taper lengths have been rounded off.
 L=Length of Taper (FT) W=Width of Offset (FT) S=Posted Speed (MPH)

TYPICAL USAGE

	MOBILE	SHORT DURATION	SHORT TERM STATIONARY	INTERMEDIATE TERM STATIONARY	LONG TERM STATIONARY
		✓	✓	✓	

GENERAL NOTES

- Flags attached to signs where shown, are REQUIRED.
 - All traffic control devices illustrated are REQUIRED, except those denoted with the triangle symbol may be omitted when stated elsewhere in the plans, or for routine maintenance work, when approved by the Engineer.
 - The CW3-4 "BE PREPARED TO STOP" sign may be installed after the CW20-4 "ONE LANE ROAD XXX FT" sign, but proper sign spacing shall be maintained.
 - Flaggers should use two-way radios or other methods of communication to control traffic.
 - Length of work space should be based on the ability of flaggers to communicate.
 - A Shadow Vehicle with a TMA should be used anytime it can be positioned 30 to 100 feet in advance of the area of crew exposure without adversely affecting the performance or quality of the work. If workers are no longer present but road or work conditions require the traffic control to remain in place, Type 3 Barricades or other channelizing devices may be substituted for the Shadow Vehicle and TMA.
 - Additional Shadow Vehicles with TMAs may be positioned off the paved surface, next to those shown in order to protect a wider work space.
- TCP (2-2a)**
- The R1-2 "YIELD" sign traffic control may be used on projects with approaches that have adequate sight distance. For projects in urban areas, work space should be no longer than one half city block. In rural areas, roadways with less than 2000 ADT, work space should be no longer than 400 feet.
 - The R1-2aP "YIELD TO ONCOMING TRAFFIC" sign shall be placed on a support at a 7 foot minimum mounting height.
- TCP (2-2b)**
- Channelizing devices on the center line may be omitted when a pilot car is leading traffic and approved by the Engineer.
 - If the work space is located near a horizontal or vertical curve, the buffer distances should be increased in order to maintain stopping sight distance to the flagger and a queue of stopped vehicles. (See table above).
 - Flaggers should use 24" STOP/SLOW paddles to control traffic. Flags should be limited to emergency situations.

Texas Department of Transportation Traffic Operations Division Standard

TRAFFIC CONTROL PLAN
ONE-LANE TWO-WAY
TRAFFIC CONTROL

TCP (2-2) - 18

FILE: tcp2-2-18.dgn	DN:	CK:	DW:	CK:
© TxDOT December 1985	CONT	SECT	JOB	HIGHWAY
REVISIONS				
8-95 3-03				COSA
1-97 2-12				
4-98 2-18				
	DIST	COUNTY	SHEET NO.	
		BEXAR	92	

162

DISCLAIMER: The use of this standard is governed by the "Texas Engineering Practice Act". No warranty of any kind is made by TxDOT for any purpose whatsoever. TxDOT assumes no responsibility for the conversion of this standard to other formats or for incorrect results or damages resulting from its use.

DATE: 1/20/2023 7:07:38 PM
 FILE: K:\COSA\DoI\osd\STANDARDS\TCP\tp2-3-18.dgn

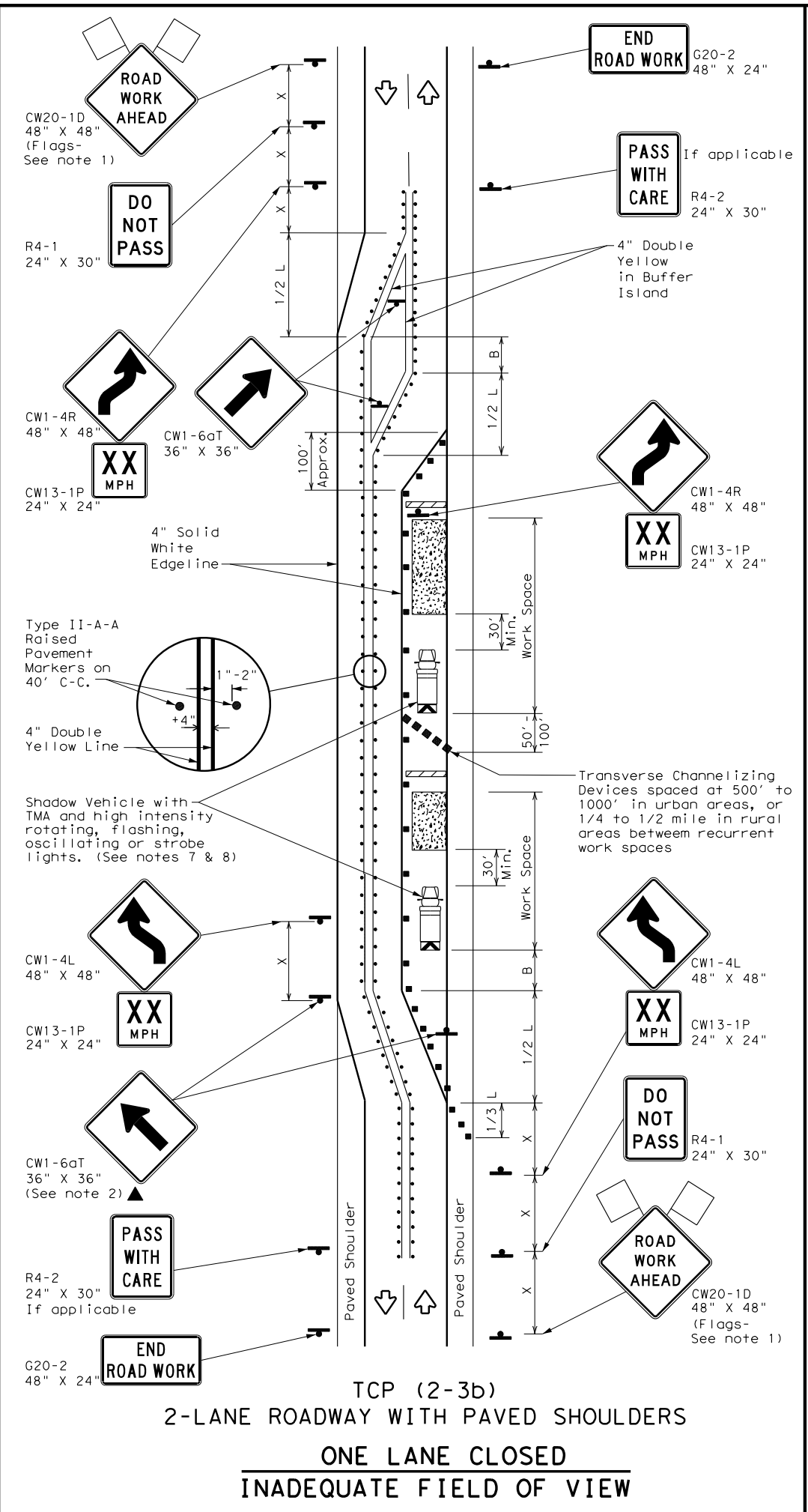
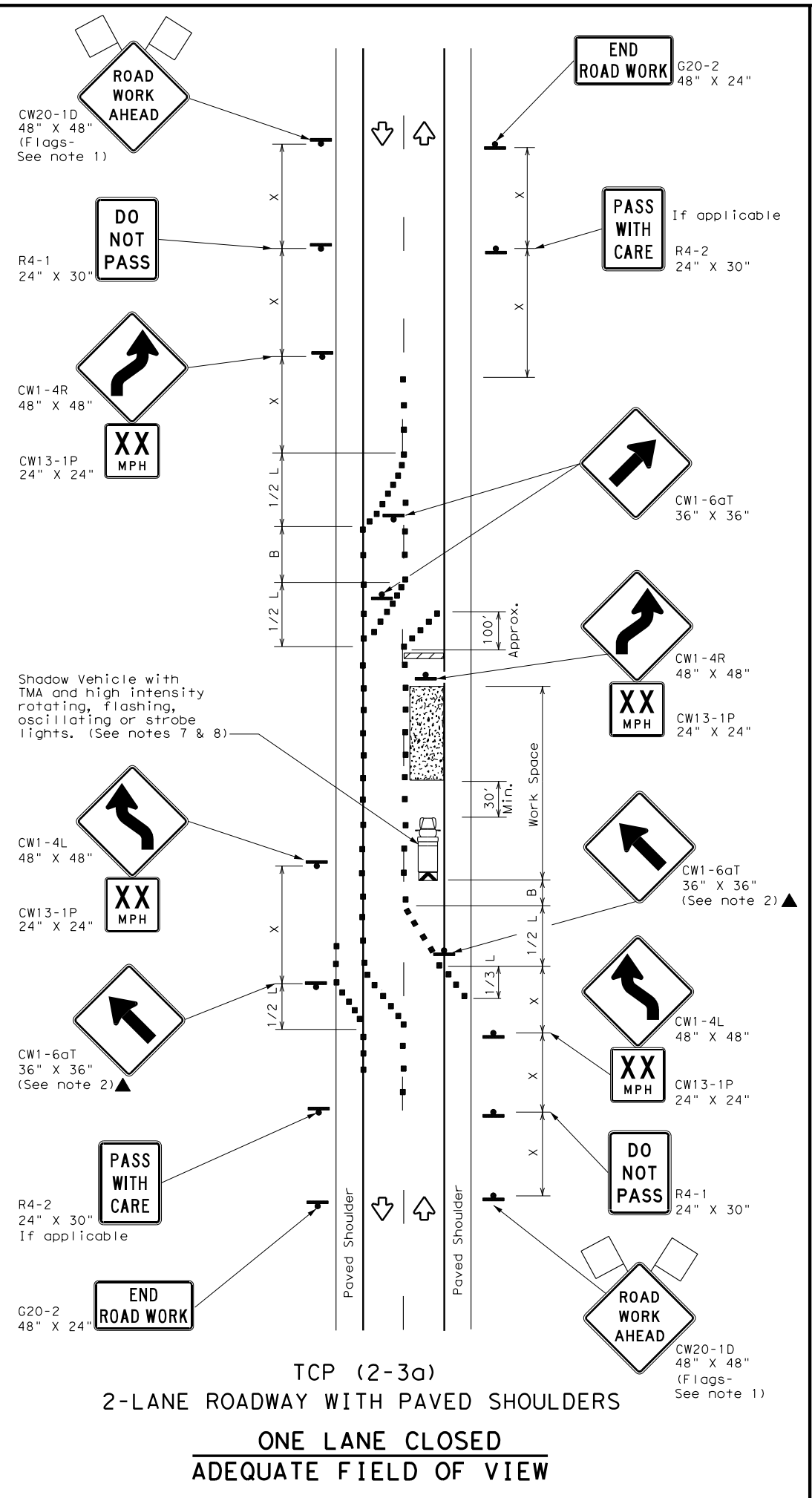

LEGEND

	Type 3 Barricade		Channelizing Devices
	Heavy Work Vehicle		Truck Mounted Attenuator (TMA)
	Trailer Mounted Flashing Arrow Board		Raised Pavement Markers Ty II-AA
	Sign		Traffic Flow
	Flag		Flagger

Posted Speed *	Formula	Minimum Desirable Taper Lengths **			Suggested Maximum Spacing of Channelizing Devices		Minimum Sign Spacing "x" Distance	Suggested Longitudinal Buffer Space "B"
		10' Offset	11' Offset	12' Offset	On a Taper	On a Tangent		
30	$L = \frac{WS^2}{60}$	150'	165'	180'	30'	70'	120'	90'
35		205'	225'	245'	35'	80'	160'	120'
40		265'	295'	320'	40'	90'	240'	155'
45	L = WS	450'	495'	540'	45'	100'	320'	195'
50		500'	550'	600'	50'	110'	400'	240'
55		550'	605'	660'	55'	120'	500'	295'
60		600'	660'	720'	60'	130'	600'	350'
65		650'	715'	780'	65'	140'	700'	410'
70		700'	770'	840'	70'	150'	800'	475'
75		750'	825'	900'	75'	160'	900'	540'

* Conventional Roads Only
 ** Taper lengths have been rounded off.
 L=Length of Taper (FT) W=Width of Offset (FT) S=Posted Speed (MPH)

TYPICAL USAGE

	MOBILE	SHORT DURATION	SHORT TERM STATIONARY	INTERMEDIATE TERM STATIONARY	LONG TERM STATIONARY
				✓	✓
					TCP (2-3b) ONLY

- GENERAL NOTES**
- Flags attached to signs where shown, are REQUIRED.
 - All traffic control devices illustrated are REQUIRED, except those denoted with the triangle symbol may be omitted when stated elsewhere in the plans, or for routine maintenance work, when approved by the Engineer.
 - When work space will be in place less than three days existing pavement markings may remain in place. Channelizing devices shall be used to separate traffic.
 - Flagger control should NOT be used unless roadway conditions or heavy traffic volume require additional emphasis to safely control traffic. Flagger should be positioned at end of traffic queue.
 - The R4-1 "DO NOT PASS," R4-2 "PASS WITH CARE" and construction regulatory speed zone signs may be installed within CW20-1D "ROAD WORK AHEAD" signs. Proper spacing of signs shall be maintained.
 - Conflicting pavement marking shall be removed for long term projects.
 - A Shadow Vehicle with a TMA should be used anytime it can be positioned 30 to 100 feet in advance of the area of crew exposure without adversely affecting the performance or quality of the work. If workers are no longer present but road or work conditions require the traffic control to remain in place, Type 3 Barricades or other channelizing devices may be substituted.
 - Additional Shadow Vehicles with TMAs may be positioned off the paved surface, next to those shown in order to protect a wider work space.
- TCP (2-3a)**
- Conflicting pavement markings shall be removed for long-term projects. For shorter durations where traffic is directed over a yellow centerline, channelizing devices which separate two-way traffic should be spaced on tapers at 20' or 15' if posted speeds are 35 mph or slower, and for tangent sections, at 1/2(S) where S is the speed in mph. This tighter device spacing is intended for the area of the conflicting markings, not the entire work zone.

Texas Department of Transportation
 Traffic Operations Division Standard

TRAFFIC CONTROL PLAN
TRAFFIC SHIFTS ON
TWO-LANE ROADS

TCP (2-3) - 18

FILE: tcp(2-3)-18.dgn	DN:	CK:	DW:	CK:
© TxDOT December 1985	CONT	SECT	JOB	HIGHWAY
REVISIONS				
8-95 3-03				COSA
1-97 2-12				
4-98 2-18				
	DIST	COUNTY	SHEET NO.	
		BEXAR	93	

163

DATE: 1/20/2023 7:07:45 PM
 FILE: K:\COSA_Dolosa\STANDARDS\TCP\tcp2-5-18.dgn

DISCLAIMER:
 The use of this standard is governed by the "Texas Engineering Practice Act". No warranty of any kind is made by TxDOT for any purpose whatsoever. TxDOT assumes no responsibility for the conversion of this standard to other formats or for incorrect results or damages resulting from its use.

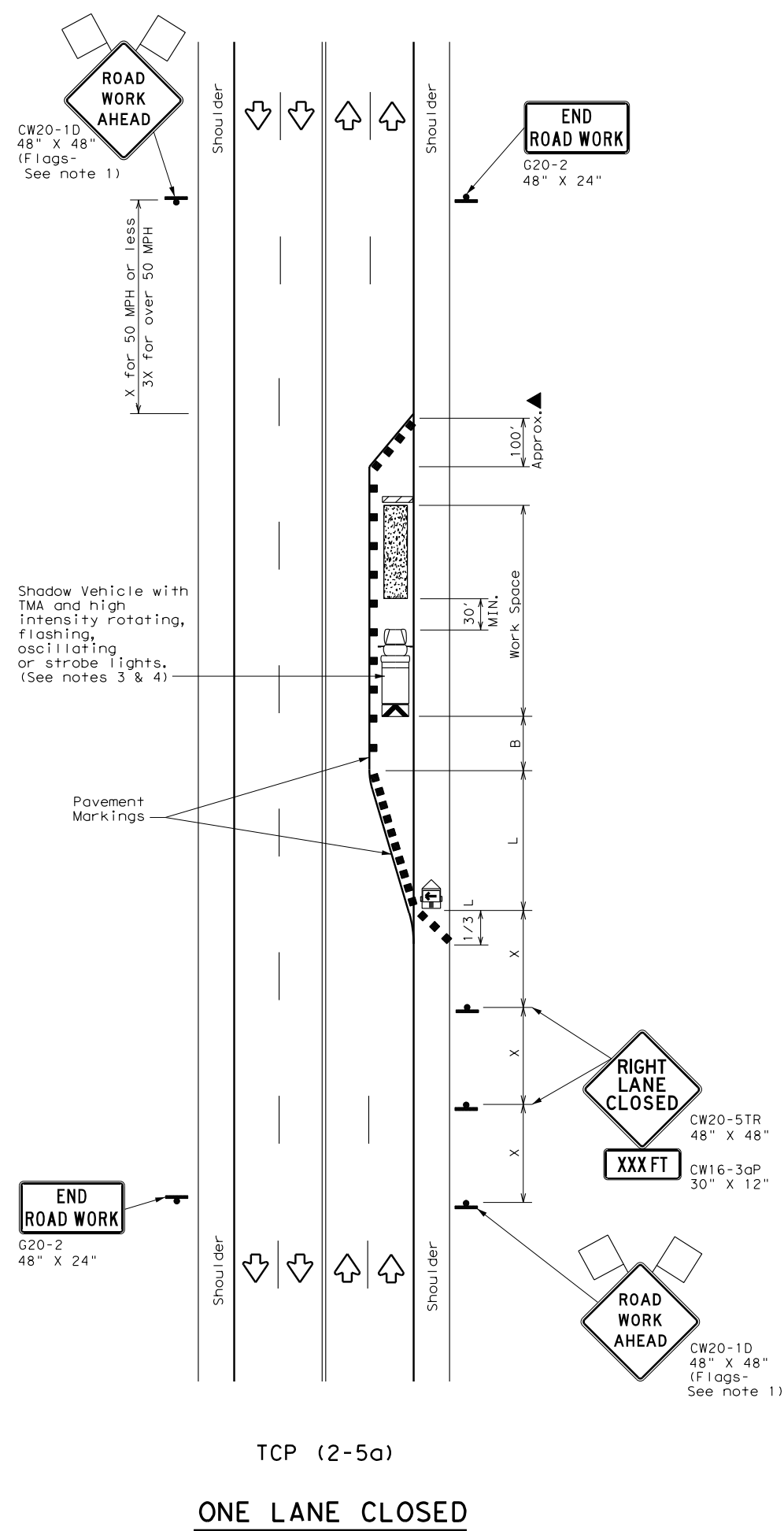

TCP (2-5a)
ONE LANE CLOSED

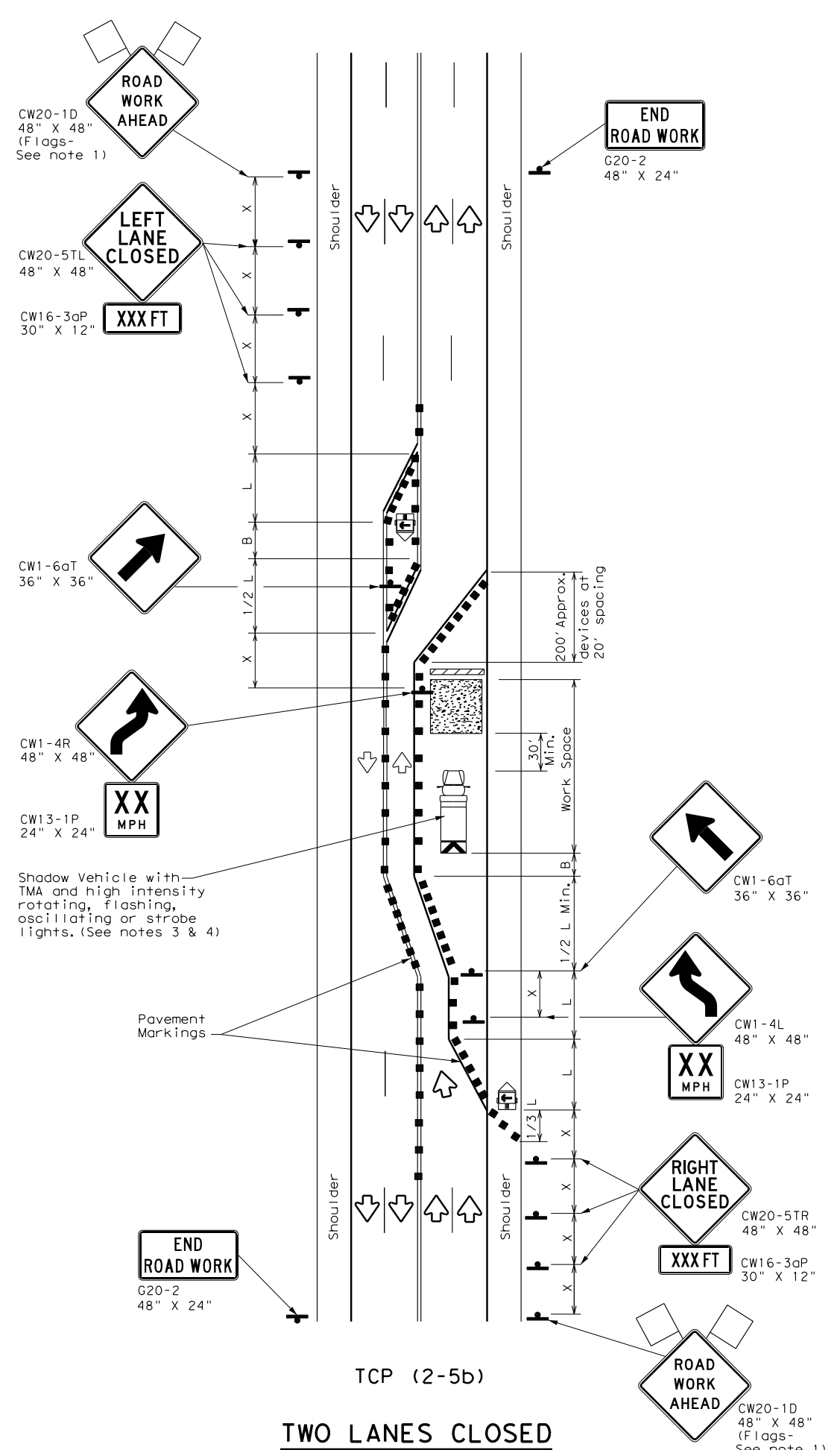

TCP (2-5b)
TWO LANES CLOSED

LEGEND			
	Type 3 Barricade		Channelizing Devices
	Heavy Work Vehicle		Truck Mounted Attenuator (TMA)
	Trailer Mounted Flashing Arrow Board		Portable Changeable Message Sign (PCMS)
	Sign		Traffic Flow
	Flag		Flagger

Posted Speed *	Formula	Minimum Desirable Taper Lengths X X			Suggested Maximum Spacing of Channelizing Devices		Minimum Sign Spacing "X" Distance	Suggested Longitudinal Buffer Space "B"
		10' Offset	11' Offset	12' Offset	On a Taper	On a Tangent		
30	$L = \frac{WS^2}{60}$	150'	165'	180'	30'	60'	120'	90'
35		205'	225'	245'	35'	70'	160'	120'
40		265'	295'	320'	40'	80'	240'	155'
45	L = WS	450'	495'	540'	45'	90'	320'	195'
50		500'	550'	600'	50'	100'	400'	240'
55		550'	605'	660'	55'	110'	500'	295'
60		600'	660'	720'	60'	120'	600'	350'
65		650'	715'	780'	65'	130'	700'	410'
70		700'	770'	840'	70'	140'	800'	475'
75		750'	825'	900'	75'	150'	900'	540'

* Conventional Roads Only
 ** Taper lengths have been rounded off.
 L=Length of Taper (FT) W=Width of Offset (FT) S=Posted Speed(MPH)

TYPICAL USAGE				
MOBILE	SHORT DURATION	SHORT TERM STATIONARY	INTERMEDIATE TERM STATIONARY	LONG TERM STATIONARY
			✓	✓

- GENERAL NOTES**
- Flags attached to signs where shown, are REQUIRED.
 - All traffic control devices illustrated are REQUIRED, except those denoted with the triangle symbol may be omitted when stated elsewhere in the plans, or for routine maintenance work, when approved by the Engineer.
 - A Shadow Vehicle with a TMA should be used anytime it can be positioned 30 to 100 feet in advance of the area of crew exposure without adversely affecting the performance or quality of the work. If workers are no longer present but road or work conditions require the traffic control to remain in place, Type 3 Barricades or other channelizing devices may be substituted for the Shadow Vehicle and TMA.
 - Additional Shadow Vehicles with TMAs may be positioned in each closed lane, on the shoulder or off the paved surface, next to those shown in order to protect a wider work space.
 - The downstream taper is optional. When used, it should be 100 feet approximately per lane, with channelizing devices spaced at 20 feet.

- TCP (2-5a)**
- If this TCP is used for a left lane closure, CW20-5TL "LEFT LANE CLOSED" signs shall be used and channelizing devices shall be placed on the centerline to protect the work space from opposing traffic, with the arrow board placed in the closed lane near the end of the merging taper.
- TCP (2-5b)**
- Conflicting pavement markings shall be removed for long-term projects.

		<i>Traffic Operations Division Standard</i>	
TRAFFIC CONTROL PLAN LONG TERM LANE CLOSURES MULTILANE CONVENTIONAL RDS.			
TCP (2-5) - 18			
FILE: tcp2-5-18.dgn	DN:	CK:	DW:
© TxDOT December 1985	CON:	SECT:	JOB:
REVISIONS		HIGHWAY	
8-95 2-12		COSA	
1-97 3-03	DIST:	COUNTY:	SHEET NO.
4-98 2-18		BEXAR	95

DISCLAIMER: The use of this standard is governed by the "Texas Engineering Practice Act". No warranty of any kind is made by TxDOT for any purpose whatsoever. TxDOT assumes no responsibility for the conversion of this standard to other formats or for incorrect results or damages resulting from its use.

DATE: 1/20/2023 7:07:48 PM
 FILE: K:\COSA_Doloresa\STANDARDS\TCP\tcp3-1.dgn

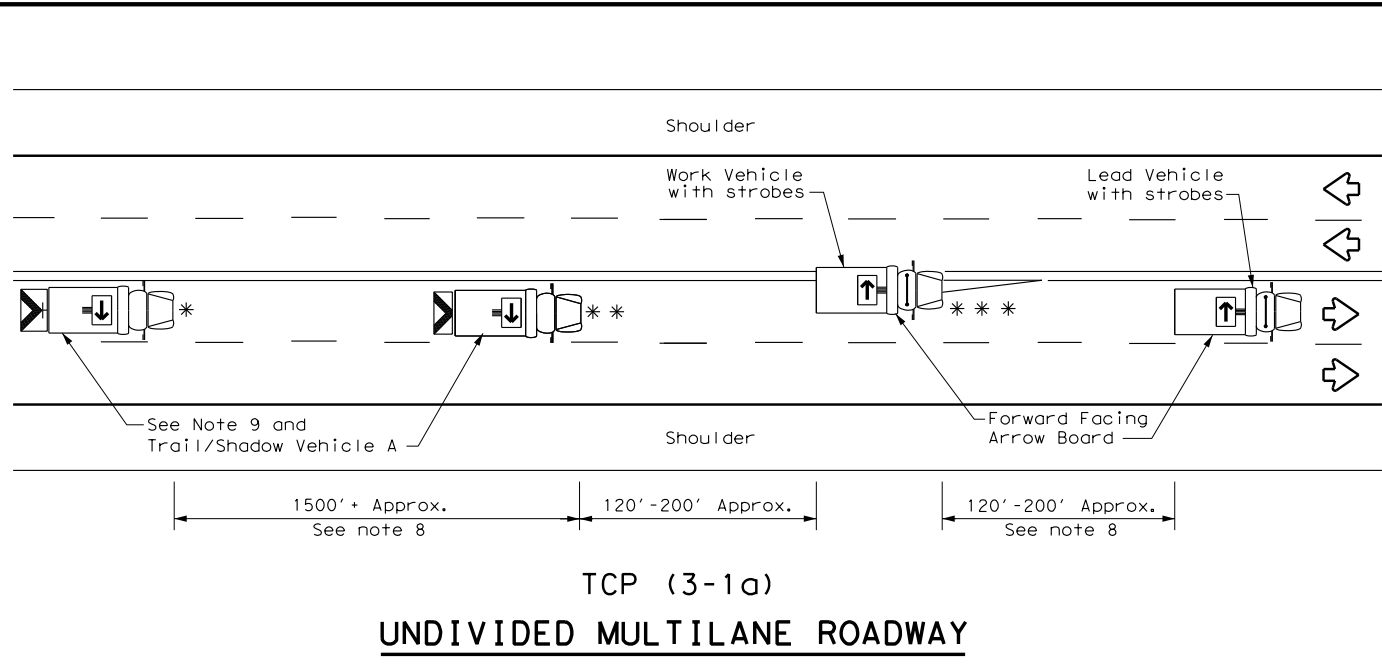

TCP (3-1a)
UNDIVIDED MULTILANE ROADWAY

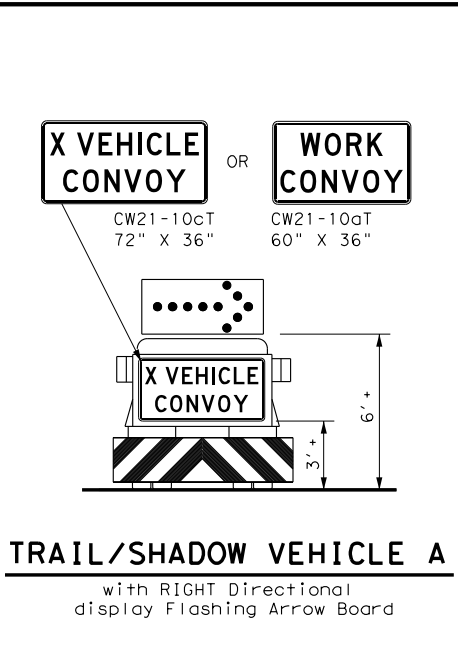

TRAIL/SHADOW VEHICLE A
 with RIGHT Directional display Flashing Arrow Board

LEGEND			
*	Trail Vehicle	ARROW BOARD DISPLAY	
**	Shadow Vehicle		
***	Work Vehicle		RIGHT Directional
	Heavy Work Vehicle		LEFT Directional
	Truck Mounted Attenuator (TMA)		Double Arrow
	Traffic Flow		CAUTION (Alternating Diamond or 4 Corner Flash)

TYPICAL USAGE				
MOBILE	SHORT DURATION	SHORT TERM STATIONARY	INTERMEDIATE TERM STATIONARY	LONG TERM STATIONARY
<input checked="" type="checkbox"/>	<input type="checkbox"/>	<input type="checkbox"/>	<input type="checkbox"/>	<input type="checkbox"/>

GENERAL NOTES

1. TRAIL, SHADOW, and LEAD vehicles shall be equipped with arrow boards as illustrated. When a LEAD vehicle is not used the WORK vehicle must be equipped with an arrow board. The Engineer will determine if the LEAD VEHICLE and/or TRAIL VEHICLE are required based on prevailing roadway conditions, traffic volume, and sight distance restrictions.
2. The use of amber high intensity rotating, flashing, oscillating, or strobe lights on vehicles are required. Blue high intensity rotating, flashing, oscillating or strobe lights when mounted on the driver's side of the vehicle may be operated simultaneously with the amber beacons or strobe lights.
3. The use of truck mounted attenuators (TMA) on the SHADOW VEHICLE and TRAIL VEHICLE are required.
4. Reflective sheeting on the rear of the TMA shall meet or exceed the reflectivity and color requirements of DEPARTMENTAL MATERIAL SPECIFICATION DMS 8300, Type A.
5. Flashing arrow boards shall be Type B or Type C as per the Barricade and Construction (BC) standards. The board shall be controlled from inside the vehicle.
6. Each vehicle shall have two-way radio communication capability.
7. When work convoys must change lanes, the TRAIL VEHICLE should change lanes first to shadow the other convoy vehicles.
8. Vehicle spacing between the TRAIL VEHICLE and the SHADOW VEHICLE will vary depending on sight distance restrictions. Motorists approaching the work convoy should be able to see the TRAIL VEHICLE in time to slow down and/or change lanes as they approach the TRAIL VEHICLE. Vehicle spacing between the WORK VEHICLE and SHADOW VEHICLE and vehicle spacing between WORK VEHICLE and LEAD VEHICLE may vary according to terrain, work activity and other factors.
9. "X VEHICLE CONVOY" (CW21-10cT) or "WORK CONVOY" (CW21-10aT) signs shall be used on TRAIL VEHICLES and SHADOW VEHICLES as shown. As an option 48" X 48" diamond shaped "WORK CONVOY" (CW21-10T) or "X VEHICLE CONVOY" (CW21-10bT) signs may be used where adequate mounting space exists. When used, the X VEHICLE CONVOY sign shall have the number of the convoy vehicles displayed on the sign in the number designation "X" location. The "X VEHICLE CONVOY" sign shall not be used on the SHADOW VEHICLE if a TRAIL VEHICLE is used.
10. On two-lane two-way roadways, the work and protection vehicles should pull over periodically to allow motor vehicle traffic to pass. If motorists are not allowed to pass the work convoy, a "DO NOT PASS" (R4-1) sign should be placed on the back of the rearmost protection vehicle.

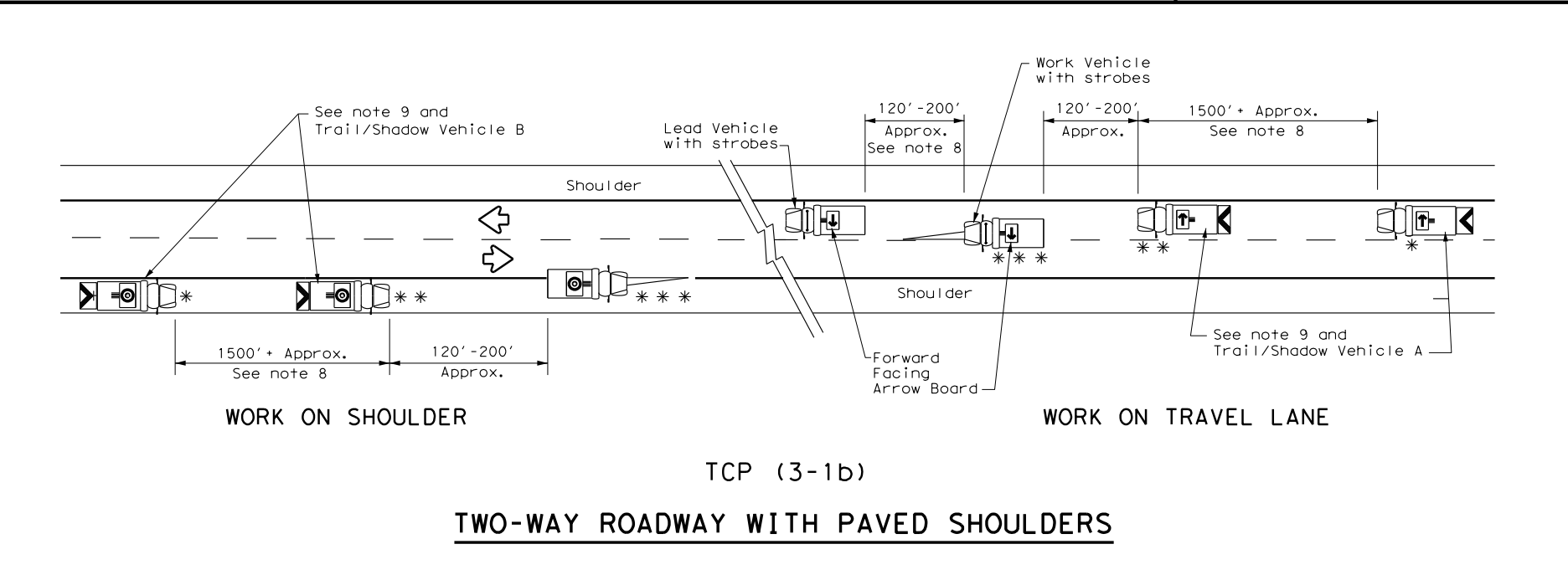

TCP (3-1b)
TWO-WAY ROADWAY WITH PAVED SHOULDERS

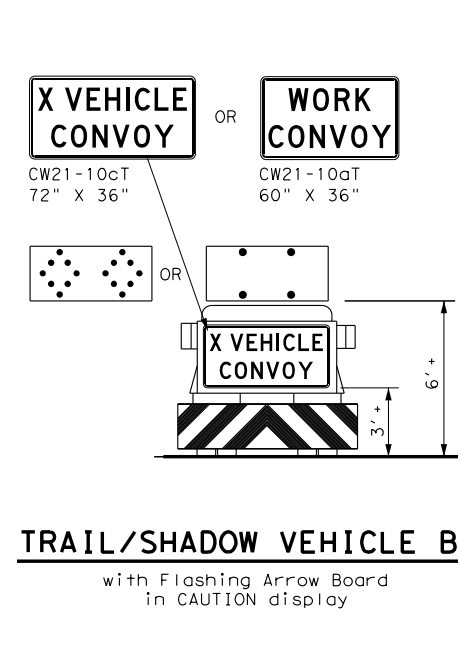

TRAIL/SHADOW VEHICLE B
 with Flashing Arrow Board in CAUTION display

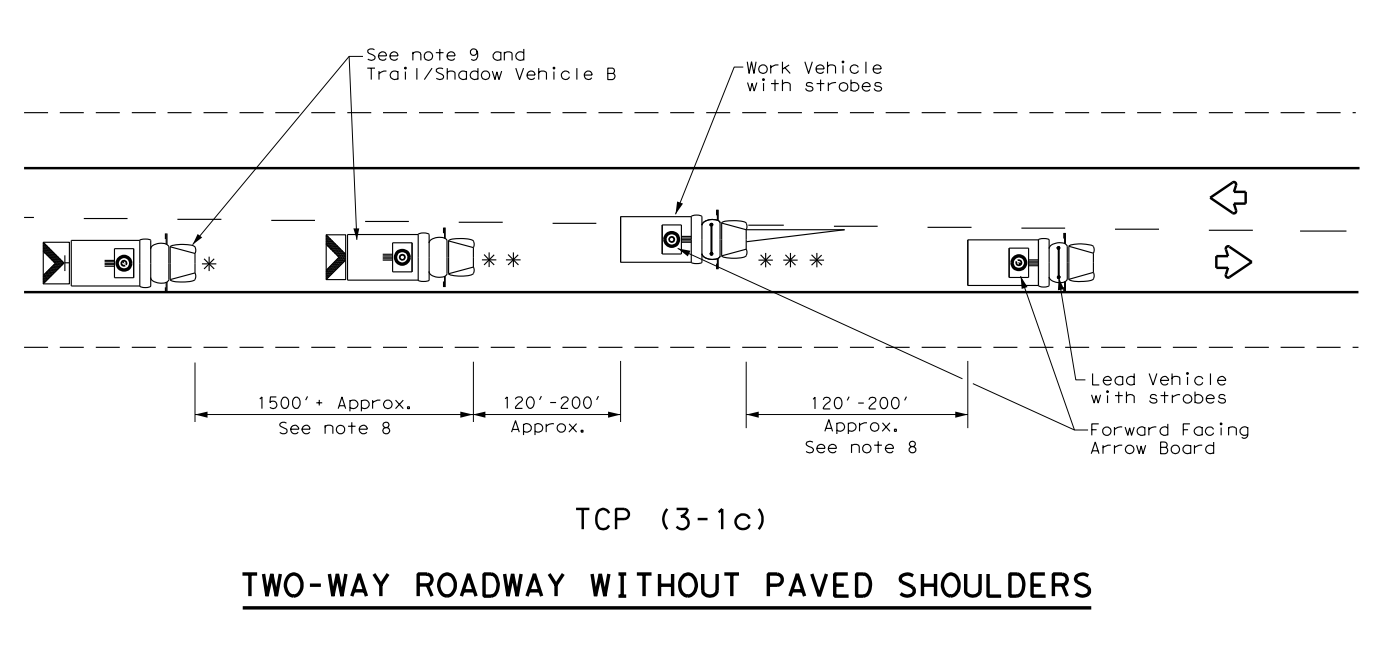

TCP (3-1c)
TWO-WAY ROADWAY WITHOUT PAVED SHOULDERS

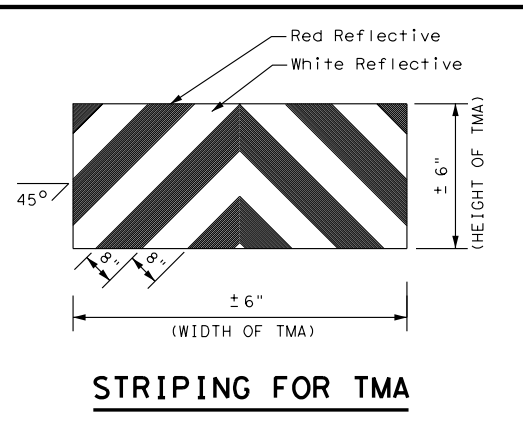

STRIPING FOR TMA

Texas Department of Transportation
 Traffic Operations Division Standard

**TRAFFIC CONTROL PLAN
 MOBILE OPERATIONS
 UNDIVIDED HIGHWAYS**

TCP (3-1) - 13

FILE:	tcp3-1.dgn	DN:	TxDOT	CK:	TxDOT	DW:	TxDOT	CK:	TxDOT
© TxDOT	December 1985	CONT	SECT	JOB	HIGHWAY				
REVISIONS									
2-94	4-98								
8-95	7-13								
1-97									
		DIST	COUNTY	SHEET NO.					
			BEXAR	96					

175

DISCLAIMER: The use of this standard is governed by the "Texas Engineering Practice Act". No warranty of any kind is made by TxDOT for any purpose whatsoever. TxDOT assumes no responsibility for the conversion of this standard to other formats or for incorrect or damages resulting from its use.

DATE: 1/20/2023 7:07:51 PM
 FILE: K:\COSA\DoI\ososa\STANDARDS\TCP\tcp3-4.dgn

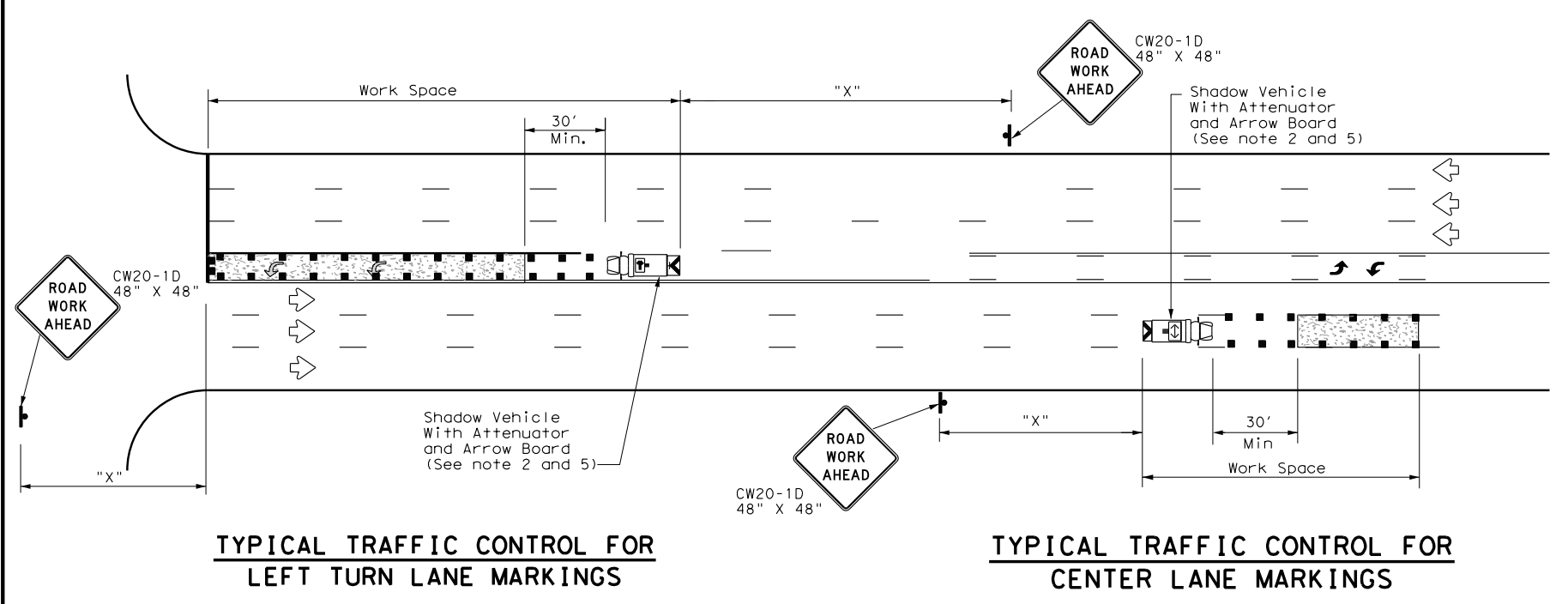
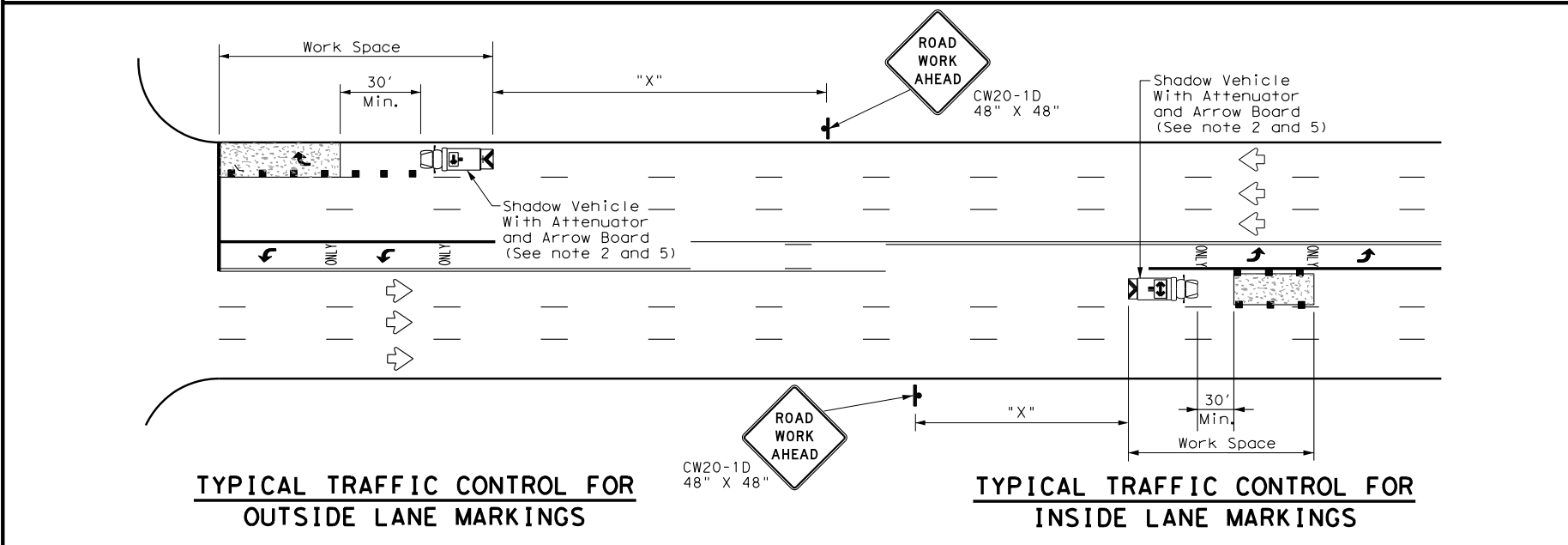
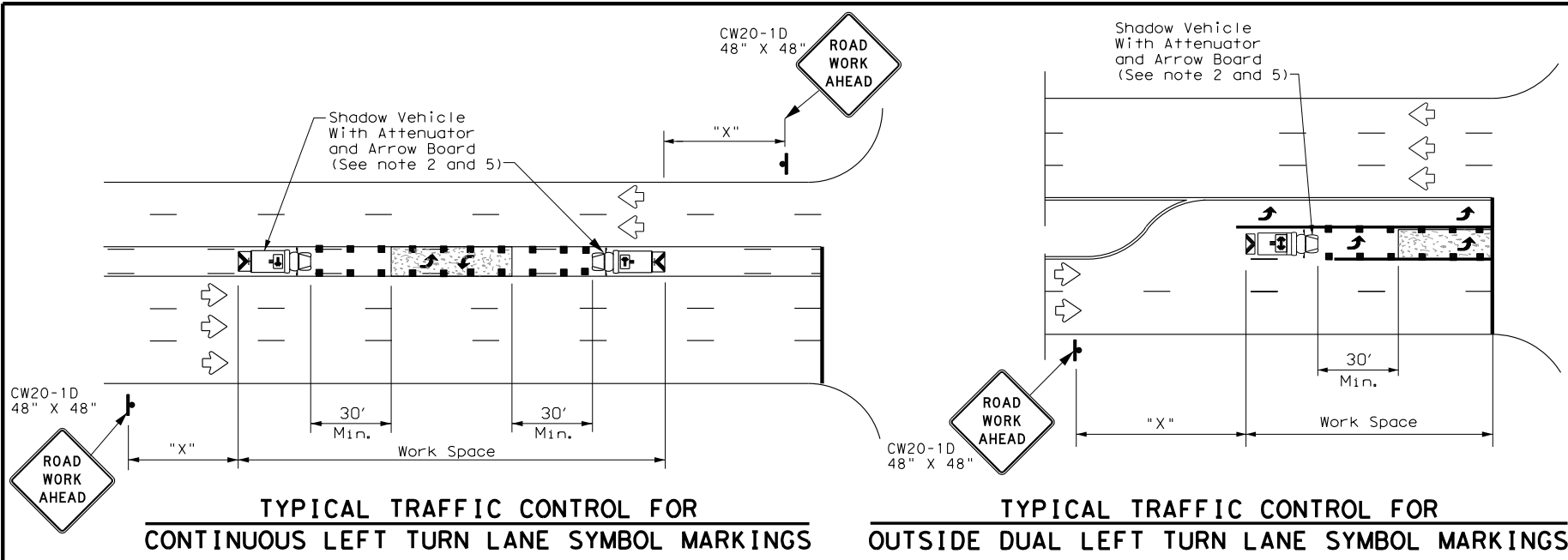

LEGEND		
*	Trail Vehicle	ARROW BOARD DISPLAY
**	Shadow Vehicle	
***	Work Vehicle	RIGHT Directional
	Heavy Work Vehicle	LEFT Directional
	Truck Mounted Attenuator (TMA)	Double Arrow
	Traffic Flow	Channelizing Devices

Posted Speed *	Formula	Minimum Desirable Taper Lengths **			Suggested Maximum Spacing of Channelizing Devices		Minimum Sign Spacing "X" Distance	Suggested Longitudinal Buffer Space "B"
		10' Offset	11' Offset	12' Offset	On a Taper	On a Tangent		
30	L = WS ² / 60	150'	165'	180'	30'	60'	120'	90'
35		205'	225'	245'	35'	70'	160'	120'
40		265'	295'	320'	40'	80'	240'	155'
45	L = WS	450'	495'	540'	45'	90'	320'	195'
50		500'	550'	600'	50'	100'	400'	240'
55		550'	605'	660'	55'	110'	500'	295'
60		600'	660'	720'	60'	120'	600'	350'
65		650'	715'	780'	65'	130'	700'	410'
70		700'	770'	840'	70'	140'	800'	475'
75		750'	825'	900'	75'	150'	900'	540'

* Conventional Roads Only
 ** Taper lengths have been rounded off.
 L=Length of Taper (FT) W=Width of Offset (FT) S=Posted Speed (MPH)

TYPICAL USAGE				
MOBILE	SHORT DURATION	SHORT TERM STATIONARY	INTERMEDIATE TERM STATIONARY	LONG TERM STATIONARY
✓				

GENERAL NOTES

1. This traffic control plan is for use on conventional roads posted at 45 mph or less and is intended for mobile operations that move continuously or intermittently (stopping up to approximately 15 minutes) such as short-line striping and in-lane rumble strips. When activities are anticipated to take longer amounts of time or traffic conditions warrant, a short duration or short-term stationary traffic control plan should be used.
2. A Truck Mounted Attenuator shall be used on Shadow Vehicle. Striping on the back panel of all truck mounted attenuators shall be 8" red and white reflective sheeting placed in an inverted "V" design. Reflective sheeting shall meet or exceed the reflectivity and color requirements of departmental material specification DMS-8300, Type A.
3. All traffic control devices shall be in accordance with the "Texas Manual on Uniform Traffic Control Devices" (TMUTCD), latest edition.
4. The use of yellow rotating beacons or strobe lights on vehicles are required. Blue high intensity rotating, flashing, oscillating or strobe lights when mounted on the drivers side of the vehicle may be operated simultaneously with the amber beacons or strobe lights.
5. Flashing arrow board shall be used on Shadow Vehicle. Flashing arrow board shall be Type B or Type C as per BC Standards. The arrow board operation shall be controlled from inside the truck.

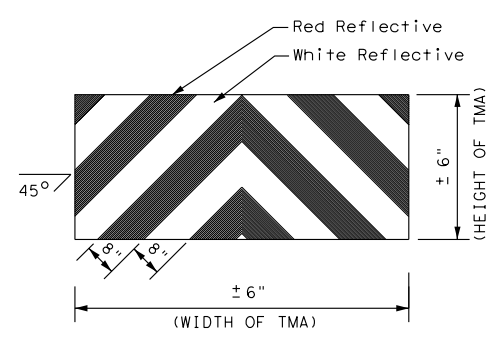

Texas Department of Transportation
 Traffic Operations Division Standard

**TRAFFIC CONTROL PLAN
 MOBILE OPERATIONS FOR
 ISOLATED WORK AREAS
 UNDIVIDED HIGHWAYS**

TCP (3-4) - 13

FILE: tcp3-4.dgn	DN: TxDOT	CK: TxDOT	DN: TxDOT	CK: TxDOT
© TxDOT July, 2013	CONT	SECT	JOB	HIGHWAY
REVISIONS	DIST	COUNTY	SHEET NO.	
		BEXAR	97	